



10W RAD HARD DC TO DC CONVERTER

7010RH SERIES

FEATURES:

- Radiation Hardened to 100 krad (Method 1019 Condition A)
- Aerospace TOR ready design
- NASA S-311-P-829 Compliant Capacitors
- Fixed Frequency of 500kHz
- 16V to 50V Input Operating Range
- Contact the Factory for Output Voltage other than 3.3V
- Current Mode Control
- Cycle by Cycle Current Limit
- User Selectable Over Current Latch Off or Constant Current Limit
- Fully Isolated, No Opto-Couplers
- Peak Efficiency Exceeding 73%
- Internally Compensated
- Softstart and Under Voltage Lockout
- Shutdown Pin For Supply Sequencing
- Internal EMI Filter
- Non-Rad Hard EDU's Available

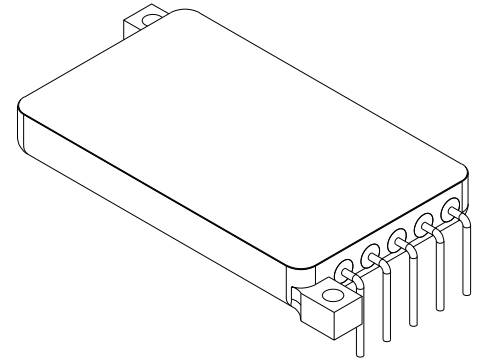

DESCRIPTION:

The MSK7010RH is a 10W radiation hardened fully isolated DC to DC converter. The MSK7010RH simplifies design of high efficiency radiation hardened power supplies and requires a minimum amount of board space. High efficiency minimizes input bus loading. User selectable over current fault response allows the designer to select between latching power off or constant current output in the event of an overload. The MSK7010RH is hermetically sealed in a 7 pin powerpack with straight or formed leads and is specifically designed for space/satellite applications.

BLOCK DIAGRAM

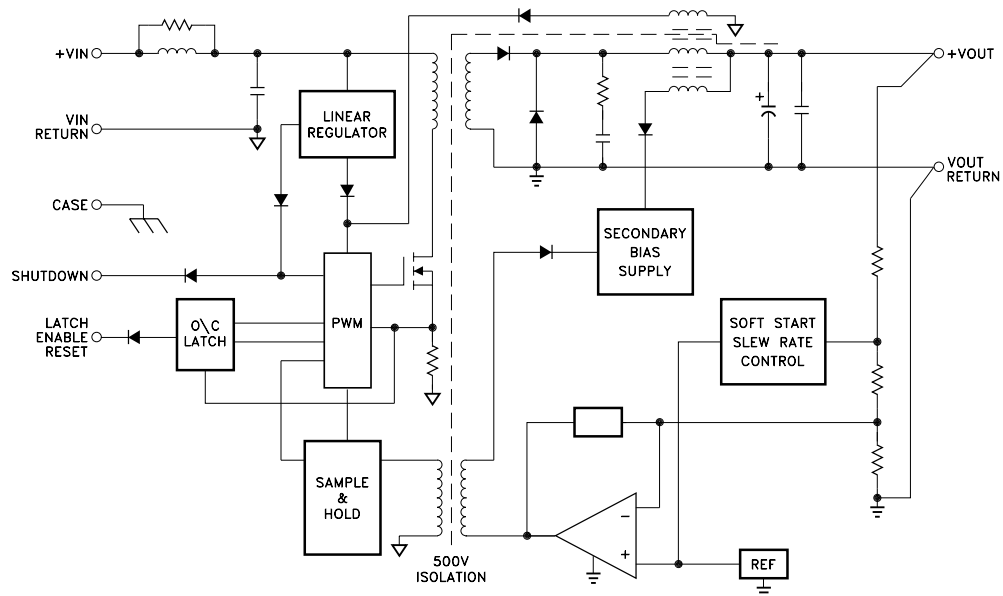

TYPICAL APPLICATIONS

- GEO and LEO Satellite System Power Supply
- Launch Vehicle Systems
- Microprocessor, ASIC, FPGA Power Supply
- High Efficiency Low Voltage Subsystem Power Supply

PIN-OUT INFORMATION

- 1 +VIN
- 2 VIN RETURN
- 3 CASE
- 4 LATCH ENABLE/RESET
- 5 SHUTDOWN
- 6 +VOUT
- 7 VOUT RETURN

ABSOLUTE MAXIMUM RATINGS

⑥

+VIN	60V
LATCH and SHUTDOWN Voltage	40V
IOUT	4.0A

T _{ST}	Storage Temperature Range	-65°C to +150°C
T _{LD}	Lead Temperature Range (10 Seconds)	300°C
	Power Dissipation	See Efficiency Curves
T _J	Junction Temperature	+150°C
	ESD Rating	CLASS 1C
T _C	Case Operating Temperature Range	
	MSK7010K/H RH	-55°C to +125°C
	MSK7010RH	-40°C to +85°C
	MSK7010EDU	-40°C to +85°C

ELECTRICAL SPECIFICATIONS

Parameter	Test Conditions ① ⑦ ⑧	Group A Subgroup	MSK7010-3.3H/K RH			MSK7010-3.3RH/EDU			Units
			Min.	Typ.	Max.	Min.	Typ.	Max.	
Output Voltage	16V ≤ VIN ≤ 50V 0A ≤ Iout ≤ 3A	1	3.27	3.30	3.33	3.27	3.30	3.33	V
		2, 3	3.25	-	3.35	-	-	-	
	Post Irradiation	1	3.25	-	3.35	3.25	-	3.35	
Output Voltage Regulation	16V ≤ VIN ≤ 50V 0A ≤ Iout ≤ 3A	1, 2, 3	-1.0	0.15	1.0	-1.0	0.15	1.0	%
Output Ripple Voltage	20MHz Bandwidth	1	-	30	50	-	30	50	mVpp
VIN Current, Shutdown	SHUTDOWN = 0V	1, 2, 3	-	3	5	-	3	5	mA
VIN Current	Iout = 0.0A	1, 2, 3	-	17	30	-	17	30	mA
VIN Ripple Current ②	5uH Source, 10KHz to 30MHz	4	-	15	-	-	15	-	mApp
Current limit, Latch Enabled	Latch = open	1, 2, 3	3.0	3.6	4.0	3.0	3.6	4.0	A
	Latch = 0V, ΔVOULT = -10%	1, 2, 3	3.3	3.8	4.2	3.3	3.8	4.2	A
Efficiency		1, 2, 3	65	72	-	65	72	-	%
	Post Irradiation	1	3.3	3.5	4.2	-	-	-	
Shutdown Pin open Circuit Voltage ②		1	-	12	-	-	12	-	V
Shutdown Pin Source Current	SHUTDOWN = 0V	1, 2, 3	-	1.5	3	-	1.5	3	mA
Undervoltage Lockout Thresholds	Iout = 0A	1, 2, 3	14	-	16	14	-	16	V
Undervoltage Lockout Hysteresis	Iout = 0A	1, 2, 3	0.5	1.0	-	0.5	1.0	-	V
	Post Irradiation	1	0.3	0.6	-	0.3	0.6	-	V
Phase Margin ②		4	-	90	-	-	90	-	Deg
Gain Margin ②		4	-	15	-	-	15	-	dB
Step Load Response	Iout 1.5A to 3.0A, 10A/μS	1	-200	±160	200	-200	±160	200	mVpp
Step Load Recovery Time	Iout 1.5A to 3.0A, 10A/μS	4	-	170	200	-	170	200	uS
Turn on overshoot	Toggle SHUTDOWN	4	-	0	200	-	0	200	mVpp
Turn on Delay	Toggle SHUTDOWN	4	-	1.5	5	-	1.5	5	mS
Line Rejection ②	VIN < 50kHz	4	-	60	-	-	60	-	dB
Switching Frequency		4, 5, 6	450	500	550	450	500	550	kHz
Isolation	Input to Output or any Pin to Case @ 500V	1	100	-	-	100	-	-	MΩ
Maximum Capacitive Load ②		4	-	≥2200	-	-	≥2200	-	μF
Thermal Resistance	Power Silicon Junction to Case @ 125°C	-	-	-	10	-	-	10	°C/W

NOTES:

- ① Unless otherwise specified; VIN = 28V, Iout = 3.0A. SHUTDOWN = OPEN, LATCH = 0V, CL = 0.1μF
- ② Guaranteed by design but not tested. Typical parameters are representative of actual device performance but are for reference only.
- ③ Industrial grade devices shall be tested to subgroup 1 and 4 unless otherwise specified.
- ④ Military grade "H" and "K" suffix devices shall be 100% tested to subgroups 1, 2, 3, 4, 5 and 6.
- ⑤ Subgroup 1, 4 TA = +25°C
2, 5 TA = +125°C
3, 6 TA = -55°C
- ⑥ Continuous operation at or above absolute maximum ratings may adversely effect the device performance and/or life cycle.
- ⑦ Pre and Post irradiation limits at 25°C, to 100Krad TID, are identical unless otherwise specified.
- ⑧ MSK7010EDU does not use Rad Hard Die, post irradiation specifications are not applicable.

APPLICATION NOTES

PIN FUNCTIONS

+VIN - Connect +VIN to the primary power bus positive rail. Input capacitors are typically not required if the input bus impedance is less than 11Ω below 30kHz.

VIN RETURN - Connect VIN RETURN to the primary power bus negative rail.

CASE - Provides an electrical connection to the device package only. This pin is isolated from all internal circuitry.

LATCH ENABLE/RESET - The latch pin determines the behavior of the converter during an over current event. Open circuit this pin to allow the converter to latch off the output if an over current condition is detected. Connect a capacitor between the LATCH ENABLE/RESET pin and VIN RETURN to delay the latch off of the output. The value of the capacitance determines the delay time between the onset of an over current event and output shutdown. See the typical performance curves section for additional information. Toggle this pin to VIN RETURN to reset the latch and restart the converter. Connecting the latch pin to VIN RETURN will disable the latch feature and the converter will behave as a constant current source during an over current event.

SHUTDOWN - Pull this pin to VIN RETURN (typically <2.8V) to put the converter in a low power shutdown state, disabling the output and most internal circuitry. Open or pull this pin above 10V to enable the converter.

+VOUT - The +VOUT pin is the positive output, with respect to VOUT RETURN. Output capacitors are not typically required, however high frequency ceramic capacitance mounted near the load are recommended to support fast load transients. Additional bulk capacitance connected to this pin is acceptable. However, excessive output capacitance may negatively affect dynamic response. The output is floating and a negative load voltage can be obtained by grounding +VOUT and connecting the load from VOUT RETURN to ground.

VOUT RETURN - The VOUT RETURN pin is the NEGATIVE OUTPUT, it is the load current return pin when the MSK7010 is connected as a positive power source. Connect to the load negative terminal with low impedance traces to minimize load regulation error.

TOTAL DOSE RADIATION TEST PERFORMANCE

Radiation performance curves for TID testing have been generated for all testing performed by MSK. These curves show performance trends throughout the TID process and can be located in the MSK7010RH radiation test report. The complete test report will be available in the RAD HARD PRODUCTS section of the MSK website.

TYPICAL APPLICATION CIRCUIT #1

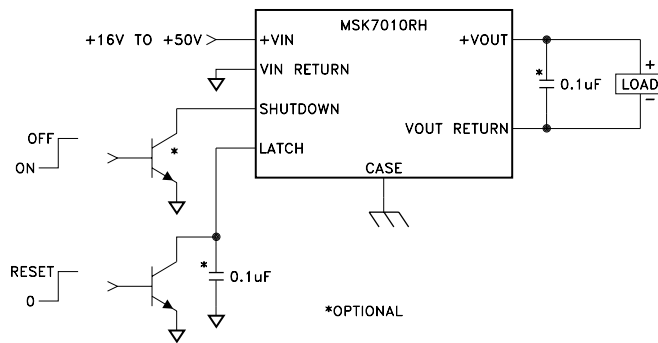

Active high shutdown and latch reset.
10mS latch off delay.

TYPICAL APPLICATION CIRCUIT #2

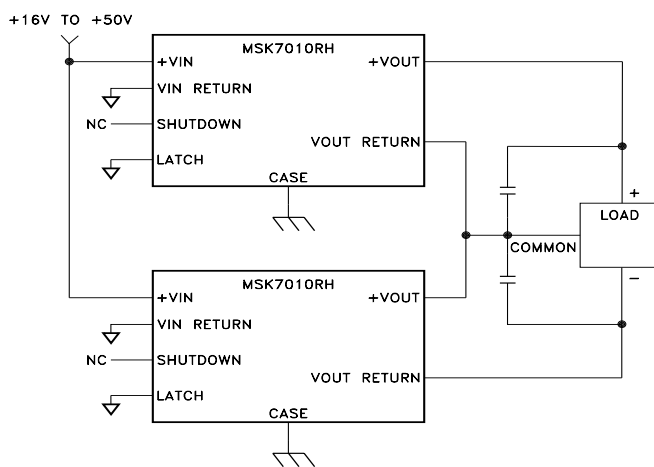

Split +/- Power Supply

TYPICAL APPLICATION CIRCUIT #3

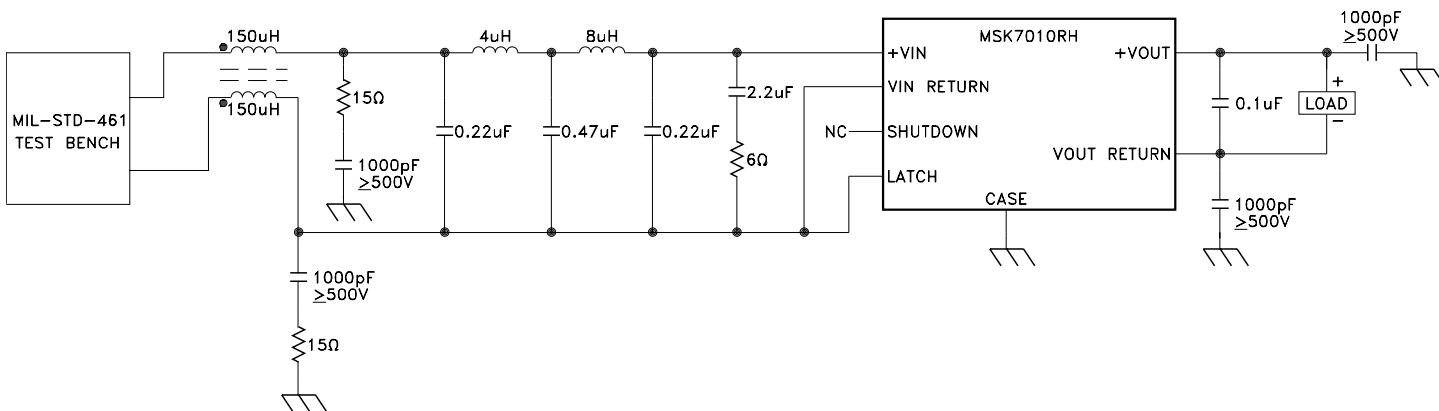

MIL-STD-461 CE & CS compliant input filter
MIL-STD-704F power bus

TYPICAL PERFORMANCE CURVES

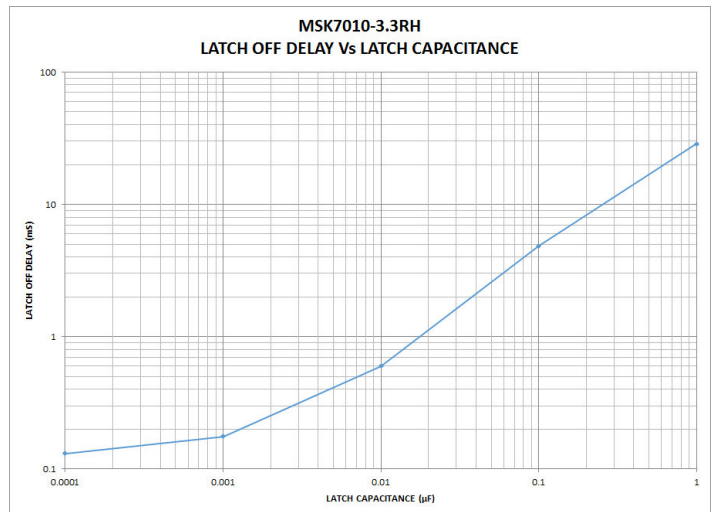
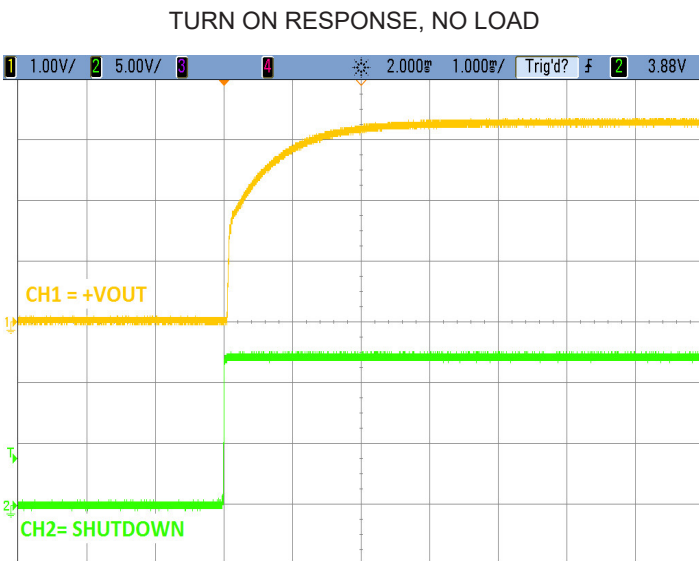
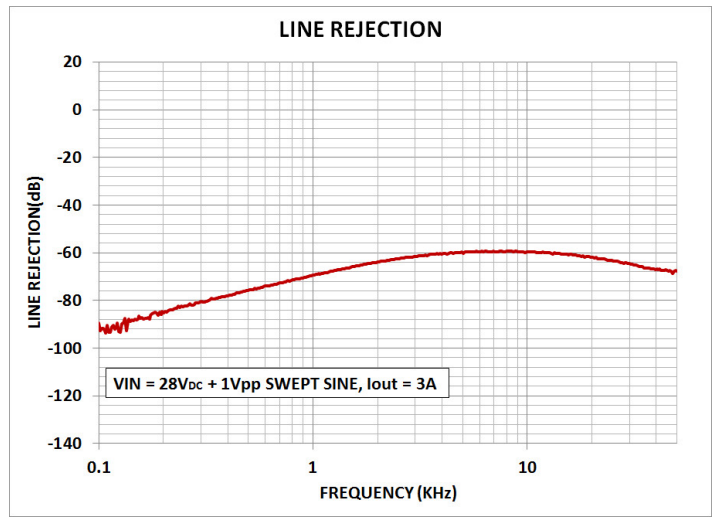
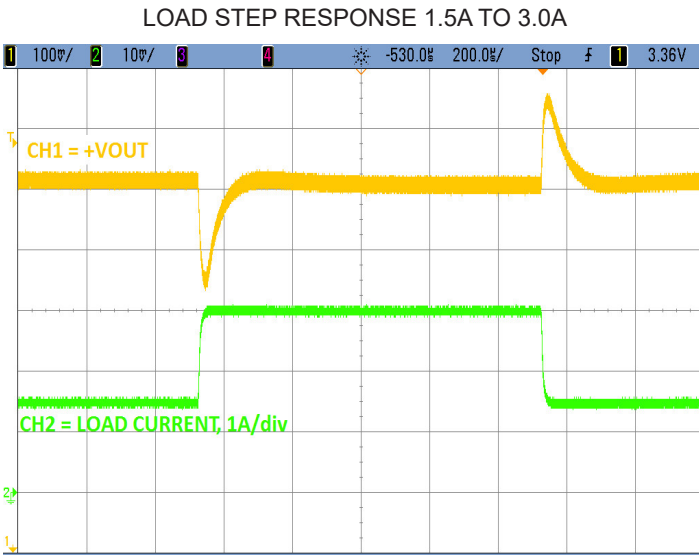
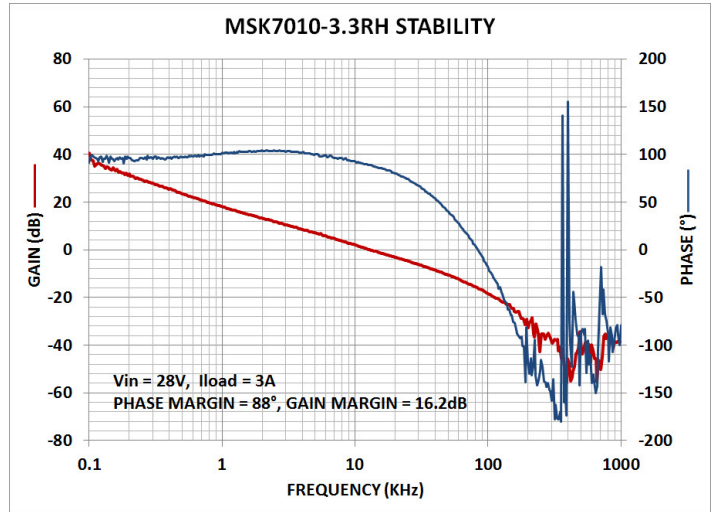
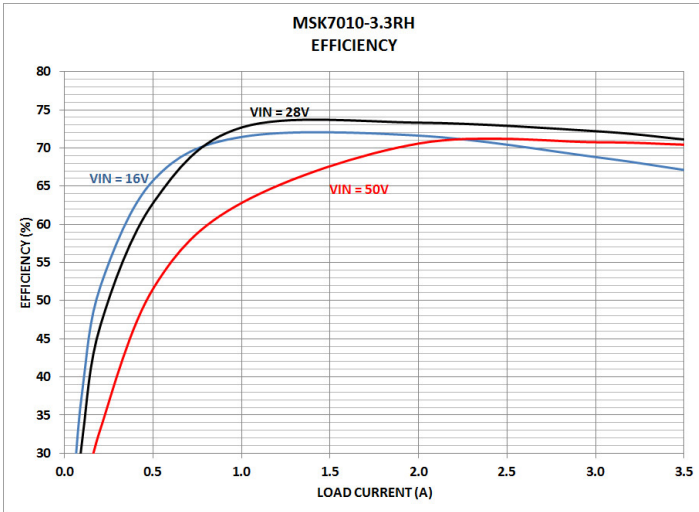

MECHANICAL SPECIFICATIONS

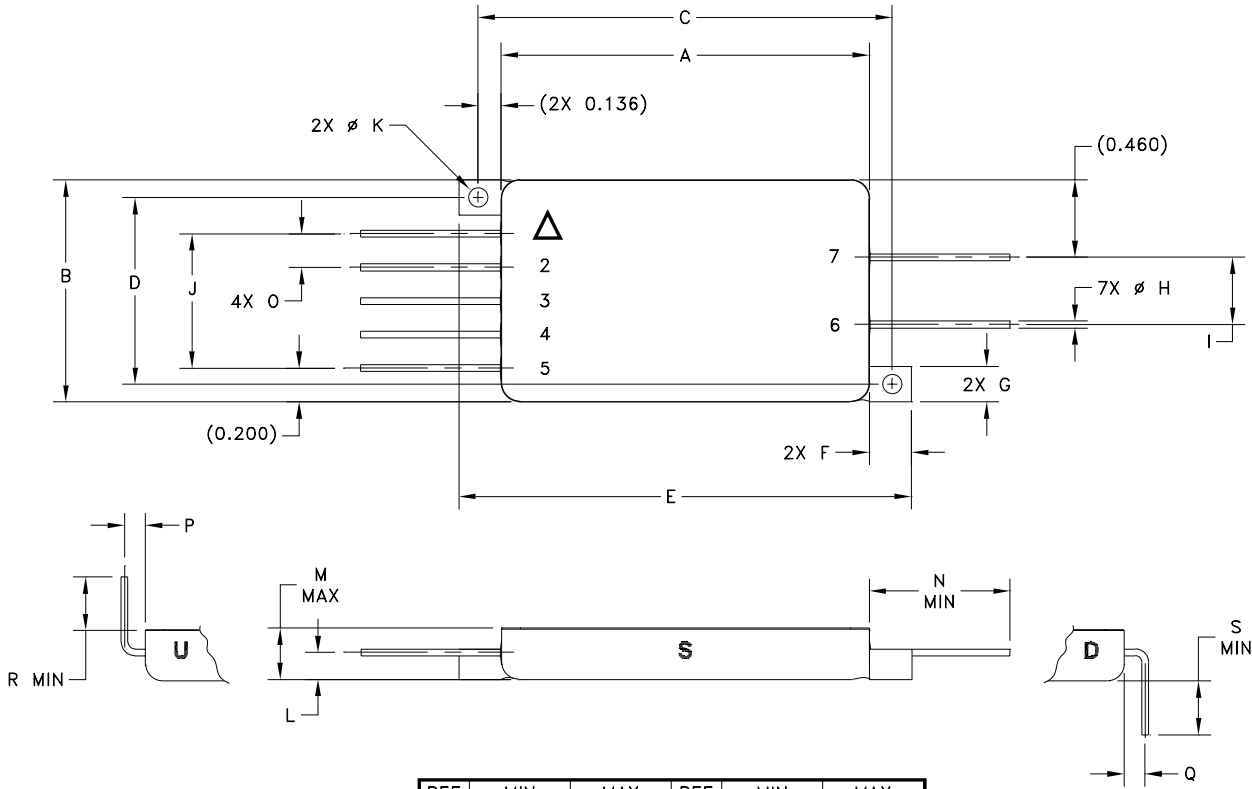

REF	MIN	MAX	REF	MIN	MAX
A	2.180	2.200	K	0.108	0.122
B	1.310	1.330	L	0.150	0.170
C	2.452	2.472	M		0.325
D	1.100	1.120	N	0.750	
E	2.680	2.700	O	0.190	0.210
F	0.245	0.255	P	0.105	0.145
G	0.205	0.215	Q	0.105	0.145
H	0.037	0.043	R	0.250	
I	0.390	0.410	S	0.250	
J	0.780	0.820			

ESD TRIANGLE INDICATES PIN 1
WEIGHT = 55 GRAMS TYPICAL

ALL DIMENSIONS ARE SPECIFIED IN INCHES

ORDERING INFORMATION

MSK7010-3.3 RH

LEAD FORM OPTIONS

S = STRAIGHT; U = BENT UP; D = BENT DOWN

RADIATION HARDENED

RH = RADIATION HARDENED

EDU = NON RAD HARD ENG UNITS;

SCREENING

BLANK = INDUSTRIAL; H = MIL-PRF-38534 CLASS H;

K = MIL-PRF-38534 CLASS K

OUTPUT VOLTAGE

3.3 = 3.3V

GENERAL PART NUMBER

REVISION HISTORY

REV	STATUS	DATE	DESCRIPTION
A	Preliminary	09/16	Initial Release
B	Preliminary	06/17	Update Specs & Performance Curves
C	Preliminary	07/17	Correct Current Limit Specs, Output Capacitor
D	Preliminary	02/18	Update front page bullet points, VIN Range and TOR ready; add ESD rating
E	Released	02/19	Update Electrical Specifications
F	Released	10/21	Update inductor values on application circuit #3, page 3, from uF to uH

TTM Technologies
www.ttmtech.com

The information contained herein is believed to be accurate at the time of printing. TTM Technologies reserves the right to make changes to its products or specifications without notice, however and assumes no liability for the use of its products. Please visit our website for the most recent revision of this data sheet.