



M.S.KENNEDY CORP.

# RAD HARD DUAL HIGH SIDE DRIVER WITH CURRENT SENSE

# 6000RH

**FEATURES:**

- Manufactured using  RH 6105 Dice
- Radiation Hardened to 100Krad(Si) (Method 1019 Condition A)
- 100V RAD HARD MOSFETs
- Dual Configuration
- Low Profile Surface Mount Flatpack
- 12V to 44V Input Voltage Range
- 5V to 36V VCC Supply Range
- 5A Max. Rating for Rad Hard Switches
- Contact MSK for MIL-PRF-38534 Qualification Status

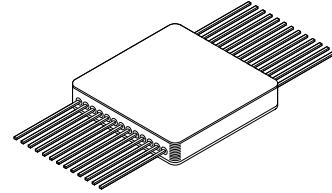

**DESCRIPTION:**

The MSK6000RH is a radiation hardened dual 5A high side switch module with a current sensing output. Each switch is independently controlled with 5V logic and can switch up to 5A maximum current. Each switch has its own independent ground reference. The current monitor outputs provide a simple method for monitoring the current in each switch. The device is designed for space applications where quality, performance and low weight are a must. The MSK6000RH is packaged in a hermetic 26 pin flatpack.

**EQUIVALENT SCHEMATIC**

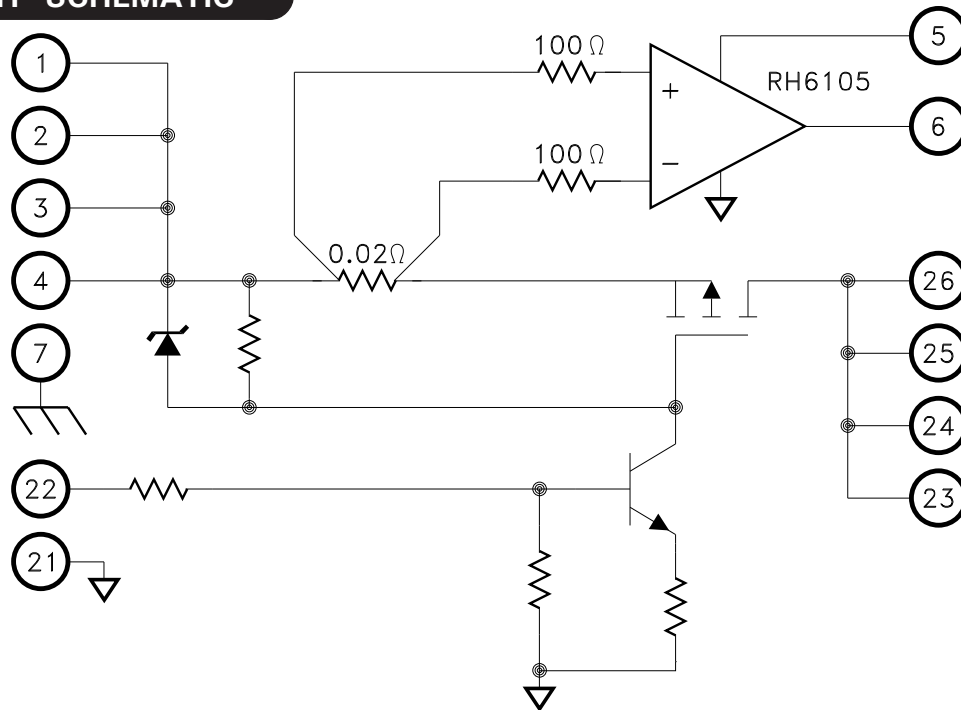

ONE OF TWO CHANNELS SHOWN

**TYPICAL APPLICATIONS**

- High Side Switch Drivers
- High Level Switching
- Space Applications
- Circuit Breaker

**PIN-OUT INFORMATION**

1	VINA	18	VOUTB	26	VOUTA
2	VINA	17	VOUTB	25	VOUTA
3	VINA	16	VOUTB	24	VOUTA
4	VINA	15	CTLB	23	VOUTA
5	VCCA	14	GNDB	22	CTLA
6	IMONA	13	IMONB	21	GNDA
7	CASE	12	VCCB	20	CASE
8	VINB	11	VINB	19	VOUTB
9	VINB	10	VINB		

 and the Linear Technology logo are registered trademarks and RH6105 is a copyright of Linear Technology Corporation

## ABSOLUTE MAXIMUM RATINGS <sup>④</sup>

VIN	Input Voltage . . . . .	44V	Ts	Storage Temperature Range . . . . .	-55°C to +150°C
VCC	Positive Supply Voltage . . . . .	36V	TL	Lead Temperature (Soldering, 10 Seconds) . . . . .	265°C
TJ	Junction Temperature . . . . .	150°C	Tc	Case Operating Temperature	
VCTL	Control Input Voltage . . . . .	6.0V		MSK6000RH . . . . .	-40°C to +85°C
IOUT	Output Current . . . . .	5A		MSK6000(K/H)RH . . . . .	-55°C to +125°C
VOUT	Output Voltage . . . . .	VIN		ESD Rating . . . . .	Class 1B

## ELECTRICAL SPECIFICATIONS

Parameter	Test Conditions <sup>①</sup>	Group A Subgroup				Units	
			Min.	Typ.	Max.		
VCC Supply Current	VCTL = N/C	1,2,3	-	175	450	μA	
VIN Supply Current	VCTL = N/C RL = N/C	1,2,3	-	30	125	μA	
	VCTL = 4V RL = N/C	1,2,3	-	1.5	5.0	mA	
Output Voltage (Off)	RL = 10K Ω	1,2,3	-	0.01	1.0	V	
Switch On Resistance <sup>⑥</sup>	IOUT = 2.5A VCTL = 4V	1	-	0.26	0.40	Ω	
		2,3	-	-	0.80	Ω	
Output Delay Times	IOUT = 2.5A Measured @ 50% Points Of Input and Output	TON	4,5,6	-	4.2	10	μS
		TOFF	4,5,6	-	21	40	μS
CTL Threshold	IOUT ≤ 100μA (OFF) IOUT ≤ 2.5A (ON)	1,2,3	0.8	2.4	4.0	V	
CTL Input Current	VCTL = 5V	1	-	-	850	μA	
Output Current <sup>②</sup>	VCTL = 4V	1	5.0	-	-	A	
IMON Gain	IOUT = 2.5A		1	0.190	0.20	0.210	mA/A
		Post Irradiation	1	0.185	0.20	0.215	mA/A
Thermal Resistance	Junction to Case, Each MOSFET	-	-	5.0	5.5	°C/W	

### NOTES:

- ① Unless otherwise specified the following test conditions shall apply: VCC = VIN = +28V, IMON Resistor = 5KΩ to ground. Parameter applies to each channel separately.
- ② Parameter, if not tested shall be guaranteed to the specified limits in table 1.
- ③ Subgroup 1,4 TA = TC = +25°C  
Subgroup 2,5 TA = TC = +125°C  
Subgroup 3,6 TA = TC = -55°C
- ④ Continuous operation at or above absolute maximum ratings may adversely effect the device performance and/or life cycle.
- ⑤ Pre and Post irradiation limits at 25°C, up to 100 Krad(Si) TID, are identical unless otherwise specified.
- ⑥ Includes internal sense resistor.

## APPLICATION NOTES

### PIN FUNCTIONS

**VIN** - The VIN pins are connected to sources of MOSFETs. They provide the voltage supply that is switched to the output pins. High di/dt can be present at these pins during switch on and off transitions. Decoupling capacitors are recommended to minimize voltage spikes.

**VCC** - The VCC pins power the current sense amplifier. The VCC pins should be connected to low impedance positive supply source.

**VOUT** - The VOUT pins connect to drains of internal MOSFETs and are the device power outputs.

**CTL** - The CTL pins connect to the high side switch enabling circuits. When a logic high voltage is present, the high side switches turn on passing power from VIN to VOUT. The CTL pin threshold has no hysteresis. It operates in a linear region between 2.0V typical (OFF) and 2.7V typical (ON) at 25°C, 1.3V typical (OFF) and 2.2V typical (ON) at 125°C, and 2.6V typical (OFF) and 3.0V typical (ON) at -55°C. Input signals with fast transitions are recommended to prevent excessive power dissipation.

**IMON** - The IMON pins connect to the output of the internal RH6105 current sense amplifiers. Voltage drop across internal current sense resistor is amplified and a scaled current is sourced from the IMON pin. The ratio of IMON current to source current is 0.20mA/A. When terminated with a 5KΩ resistor the output voltage is 1V/A.

**GND** - The GND pins are the reference for each driver circuit. Each channel has it's own ground. The control input signals and current sense outputs are referenced to the respective grounds.

**CASE** - The CASE connection pins provide an electrical connection to the MSK6000RH package. They are electrically isolated from the internal circuitry.

### TOTAL DOSE RADIATION TEST PERFORMANCE

Radiation performance curves for TID testing have been generated for all radiation testing performed by MS Kennedy. These curves show performance trends throughout the TID test process and are located in the MSK6000RH radiation test report. The complete radiation test report is available in the RAD HARD PRODUCTS section on the MSK website.

### TYPICAL APPLICATION CIRCUIT

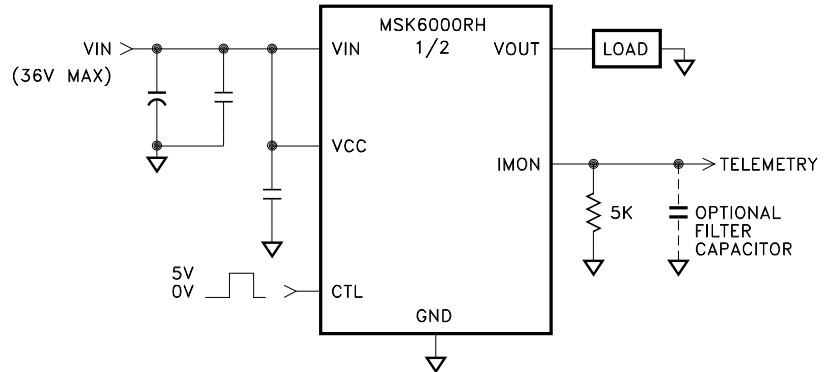

### HIGH VIN APPLICATION CIRCUIT

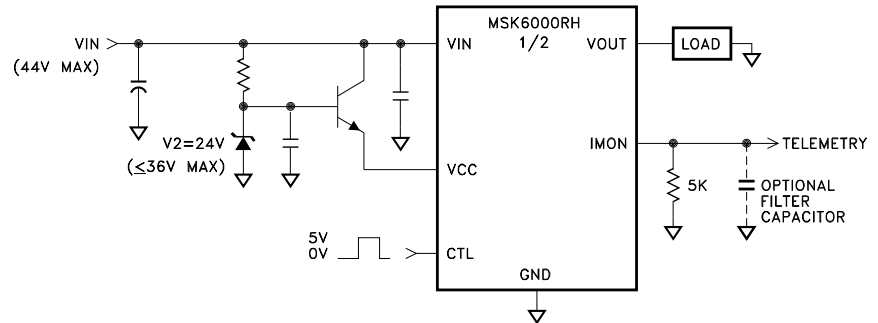

NOTE: VCC CAN BE POWERED FROM AN INDEPENDENT POWER SUPPLY

## APPLICATION NOTES

### VOUT RISE TIME CONTROL

The output rise time of the MSK6000RH and the associated surge currents can be controlled over a wide range using a few external components as shown in the simplified schematic below. Power dissipation in the MSK6000RH can increase during turn on or bus voltage transients and should be considered. The circuit below performs the rise time control function by controlling the voltage drop  $V_R$  across  $R_{BAL}$ . Assuming a constant current to linearly change the output capacitance, the MSK6000RH rise time is approximated by the following equation:

$$\frac{dV_{OUT}}{dt} = \frac{V_{RBAL}}{\beta_{Q1} \times R_{BAL} \times C_{FB}} \text{ Where } V_{RBAL} = V_C - V_{THRESHOLD}$$

### VOUT RISE TIME CONTROL CIRCUIT

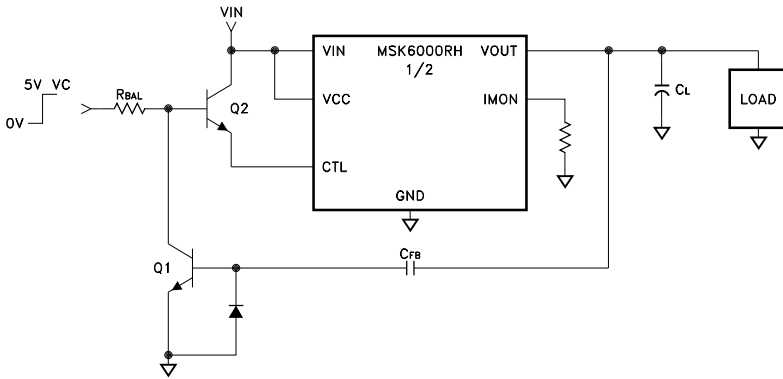

# TYPICAL PERFORMANCE CURVES

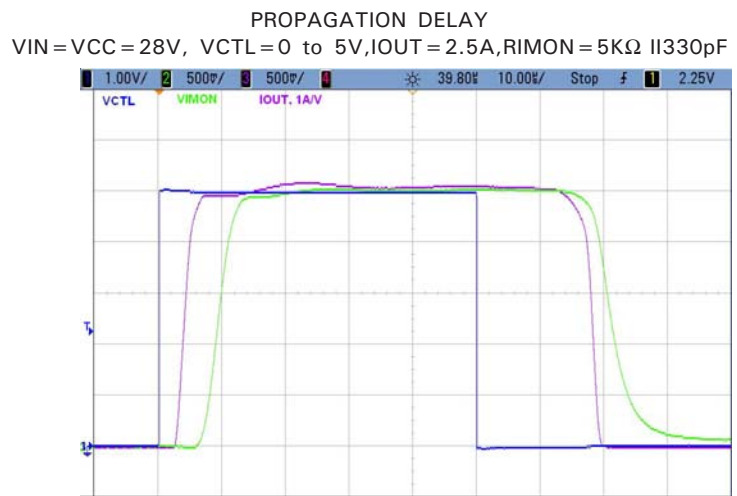
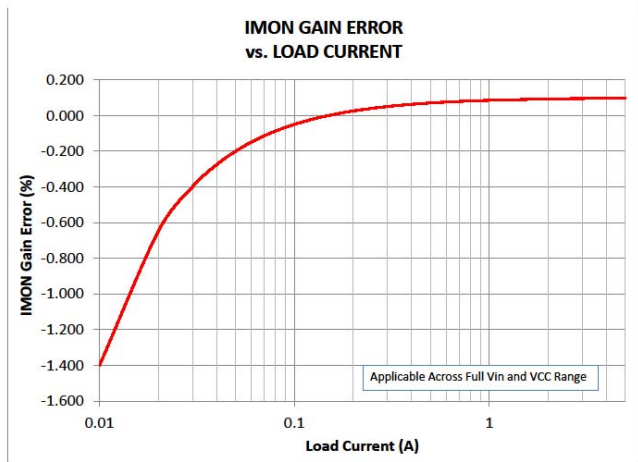
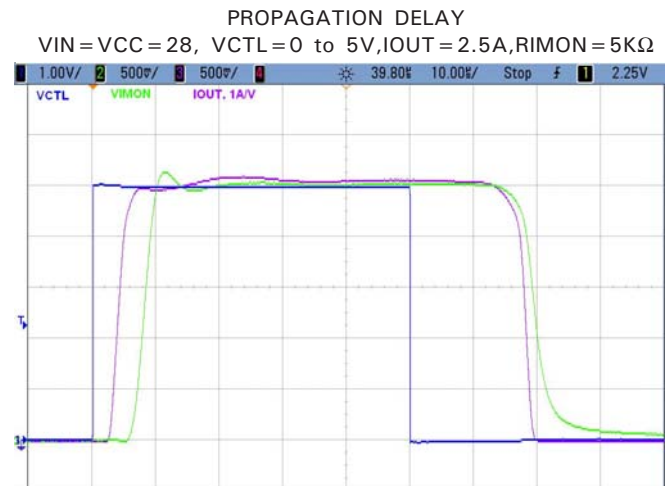
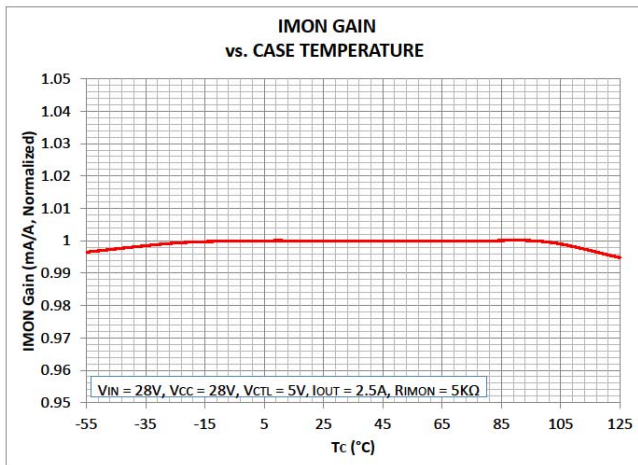
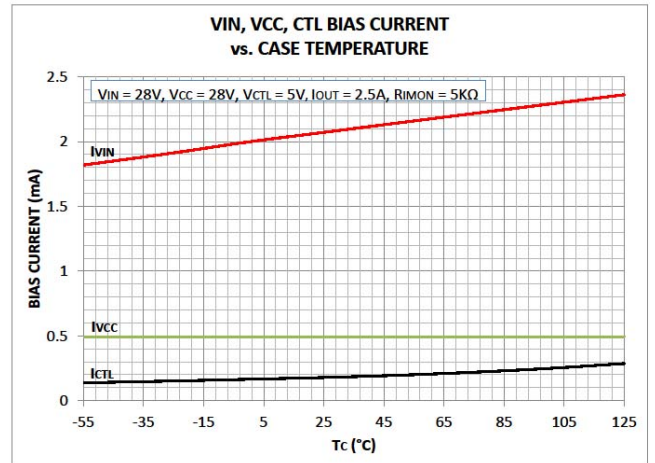
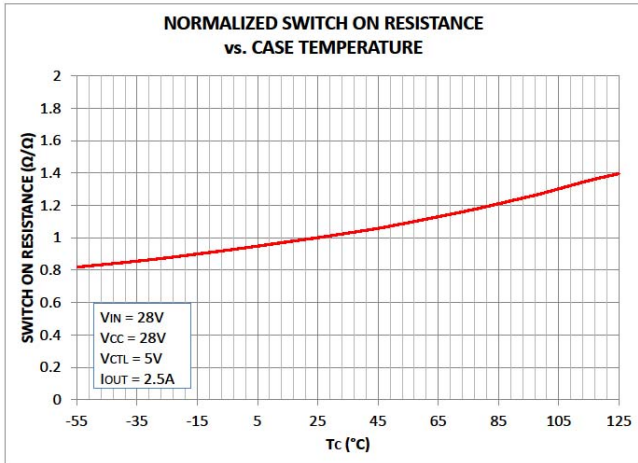

# MECHANICAL SPECIFICATIONS

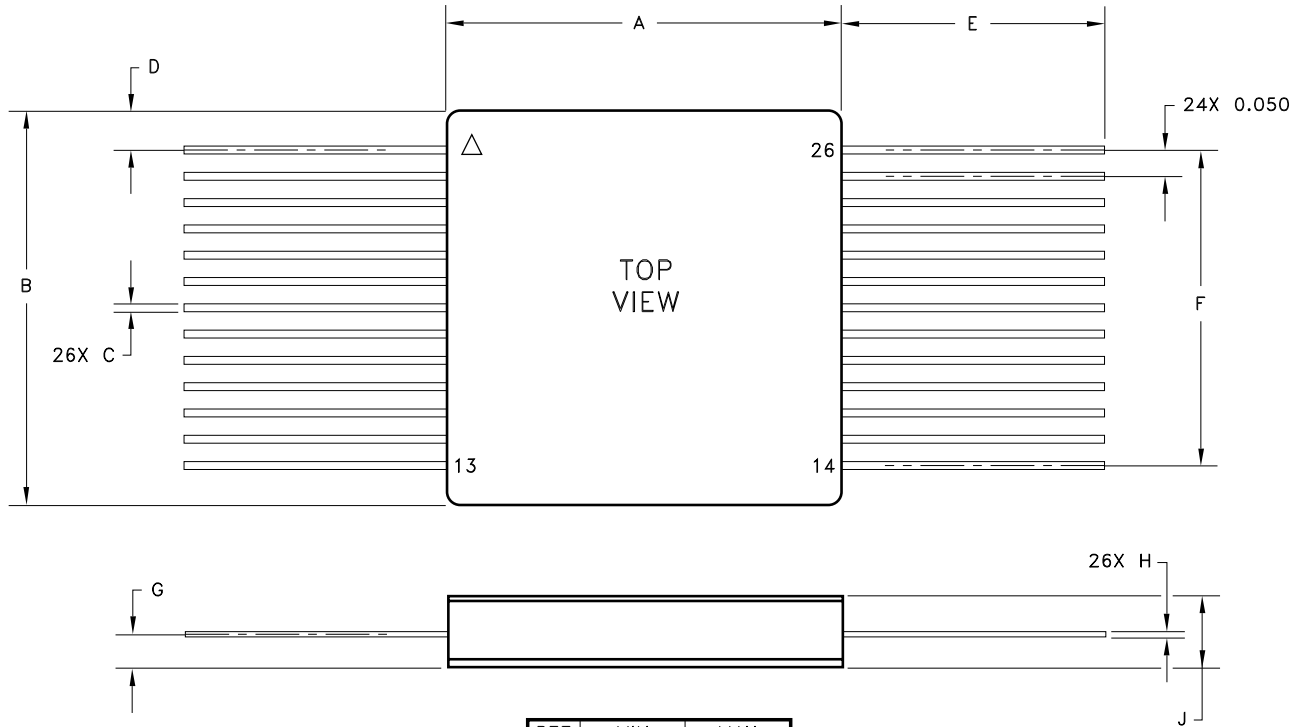

REF	MIN	MAX
A	0.740	0.760
B	0.740	0.760
C	0.013	0.020
D	0.070	0.080
E	0.450	
F	0.595	0.605
G	0.055	0.069
H	0.008	0.014
J		0.135

ESD TRIANGLE INDICATES PIN 1  
WEIGHT = 4.5 GRAMS TYPICAL

ALL DIMENSIONS ARE SPECIFIED IN INCHES

## ORDERING INFORMATION

Part Number	Screening Level
MSK6000RH	Industrial
MSK6000HRH	MIL-PRF-38534 Class H
MSK6000KRH	MIL-PRF-38534 Class K

## REVISION HISTORY

REV	STATUS	DATE	DESCRIPTION
D	Released	05/14	Add high dose rate test bullet, add post rad specs and clarify dimensions.
E	21116	06/14	Add ESD rating.
F	21365	10/14	Add slew rate control app circuit, correct sheet 2 note 5.

M.S. Kennedy Corp.  
Phone (315) 701-6751  
FAX (315) 701-6752  
[www.mskennedy.com](http://www.mskennedy.com)

---

The information contained herein is believed to be accurate at the time of printing. MSK reserves the right to make changes to its products or specifications without notice, however, and assumes no liability for the use of its products. Please visit our website for the most recent revision of this datasheet.  
Contact MSK for MIL-PRF-38534 qualification status.