

MSK6000RH Evaluation Board User's Guide

By Bob Abel & Paul Musil, MS Kennedy Corp.; Revised 9/19/2013

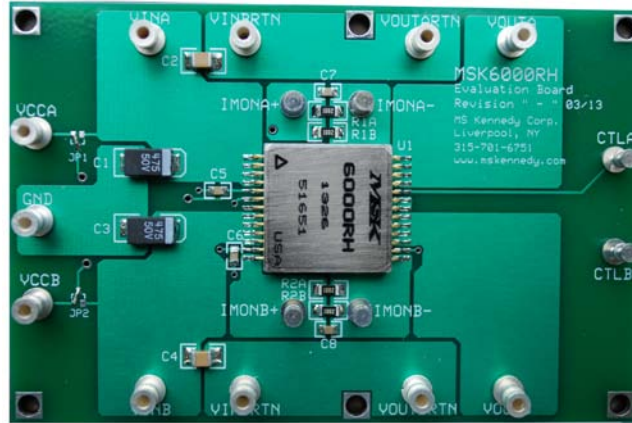

Introduction

The MSK 6000RH is a radiation hardened dual 5A high side load switch module with a current sensing output. Each switch is independently controlled with 5V logic and can switch up to 5A maximum peak current. The current monitor outputs provide a simple method for monitoring the current in each switch. The device is designed for space applications where quality, performance, and low weight are a must. The MSK 6000RH is packaged in a hermetic 26 pin flatpack. The evaluation board provides a platform from which to evaluate new designs with ample real estate to make changes and evaluate results.

This application note is intended to be used in conjunction with the MSK6000RH data sheet, and the LT6105 data sheet. Reference those documents for additional application information and specifications.

Setup

Connect the high side source to be switched/monitored to the VINA or B turret terminals, and then connect the load to the appropriate VOUTA or B terminals. Connect the load return to the VOUTARTN or VOUTBRTN, and the VINARTN or VINBRTN back to the source return. Avoid using the signal ground reference as a return path for high currents. The turrets provide an easy interface for the control circuitry, VCC and signal ground, and current monitoring. The smaller turrets are for the signal inputs and outputs for switching control and current monitoring.

Use JP1 and JP2 to connect VCC to V_{IN} if V_{IN} is less than the 36V maximum for VCC to simplify connections. The default connection is to provide a separate source for VCC, so the device can be tested with higher V_{IN} voltages.

Output Voltage & Current Monitoring

The estimated output voltage can be calculated based on the formula below when CTLA,B is above 4.0V, and is typically 0.17V when CTLA,B is below 0.6V.

$$V_{OUT} \approx V_{IN} - (I * 0.27\Omega_{(TYP.)})$$

The I_{MON} pin is connected to the output of the internal RH6105 current sense amplifier. The voltage drop across the internal current sense resistor is amplified, and a scaled current is sourced from the I_{MON} pin. The ratio of I_{MON} current to source current is 0.20mA/A. When terminated with a 5KΩ resistor (default configuration), the I_{MON} pin output voltage is 1V/A. The value of R1 or R2 can be changed if a different output is desired for a given MOSFET current.

Application Information

The MSK6000RH could be used in a variety of applications that require monitored current switching. The current monitor feature and the CTL inputs could be used as a circuit breaker with only a few external thresholding and latching/reset components.

Efficiency Considerations

The efficiency or conduction loss will vary with temperature. Worst case will be at the application's highest operating temperature. R_{DS(ON)} will increase with temperature, roughly doubling at maximum temperature, and reducing to about one half of the value at 25°C at the minimum temperature. The typical R_{DS(ON)} at 25°C is 270mΩ, and estimated I²R losses for other junction temperatures can be estimated using the normalized data and equation below:

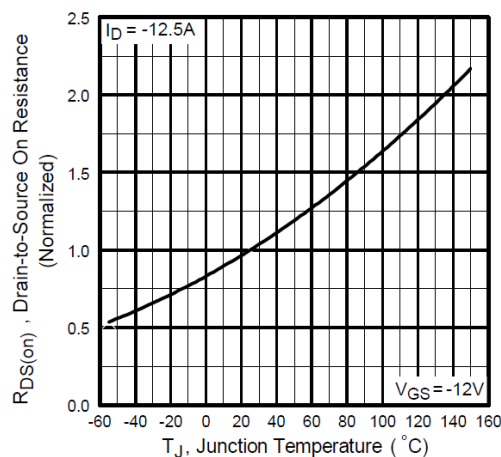

$$P_{LOSS} = I_{LOAD}^2 \cdot R_{DS(ON)}$$

This can be a benefit when current sharing because the cooler MOSFET will take more of the current because of its relatively lower resistance.

Note:

Care should be taken to avoid prolonged operation in the linear region ($0.6V < V_{CTL} < 4.0V$) to avoid excessive conduction losses. Operating in the linear region can result in excessive power dissipation. Operating with V_{IN} potentials below 12V can also cause increased power dissipation by limiting the device's ability to develop enough V_{GS} potential for full enhancement, so it is not recommended.

MSK6000RH Evaluation Board Schematic

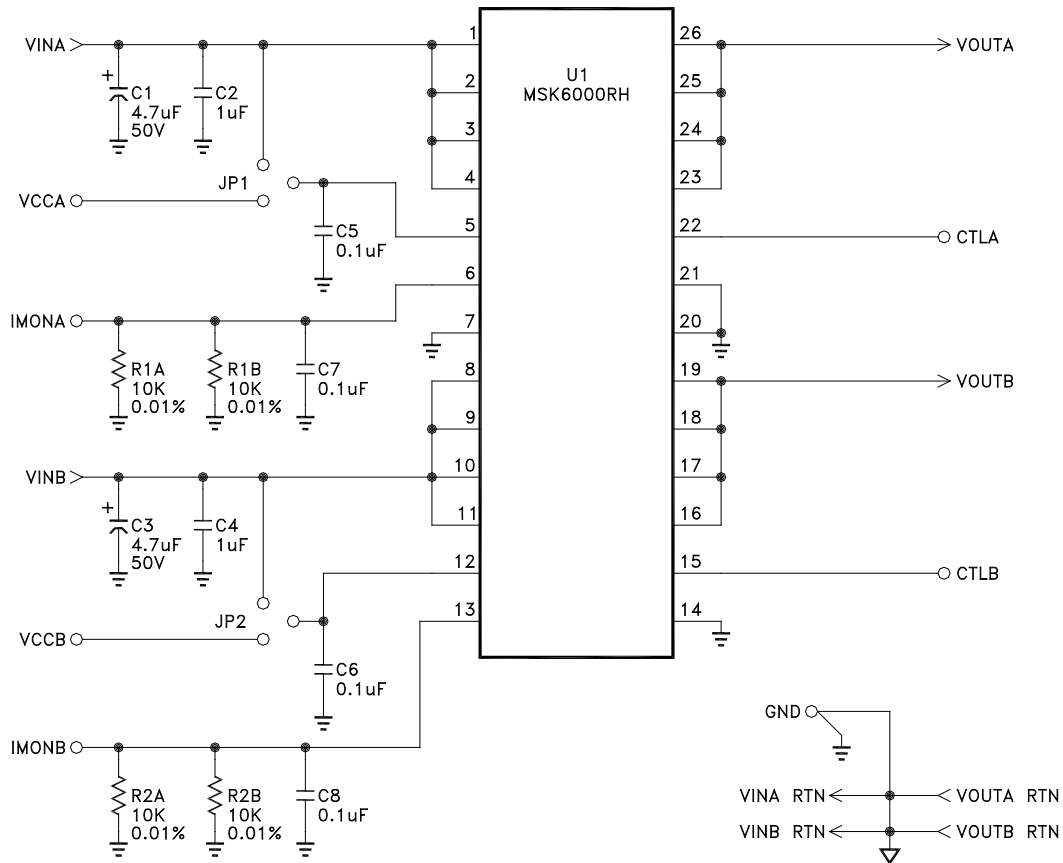

Typical Performance

Parameter	Conditions	Units	Typical
I_{MON} Gain	$V_{IN} = 28.0V, I_{OUT} = 2.5A$	mA/A	0.20
$I_{MONA,B}$ Output Voltage	$V_{IN} = 12V$ to $44V$	V/A	1.0 (Factory Default)
Propagation Delay	$V_{IN} = 28V, I_{OUT} = 2.5A$ $CTL_{A,B}$ 50% to V_{OUT} 50%	μs	4.2 On / 20.2 Off
Switch On Resistance ¹	$V_{IN} = 28V, I_{OUT} = 2.5A$	m Ω	270

¹Measurement includes PCB trace resistance @ 25°C.

PCB Artwork

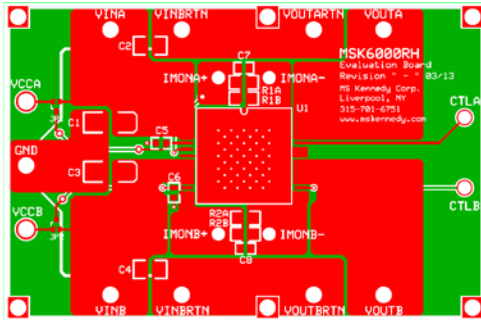

Top Side

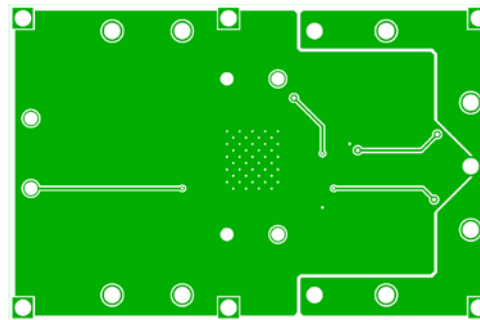

Bottom Side

Bill Of Materials

Ref Des	Description	Manufacturer	Part Number
U1	Dual High Side Driver with Current Monitor	MS Kennedy Corp.	MSK6000RH
C1	Capacitor, 4.7uF Tantalum, 50V	AVX	TAZH475K050L/CWR29NC475K
C2	Capacitor, 1uF Ceramic, 100V	AVX	12101C105K
C3	Capacitor, 4.7uF Tantalum, 50V	AVX	TAZH475K050L/CWR29NC475K
C4	Capacitor, 1uF Ceramic, 100V	AVX	12101C105K
C5	Capacitor, 0.1uF Ceramic, 50V	AVX	08055C104K
C6	Capacitor, 0.1uF Ceramic, 50V	AVX	08055C104K
C7	Capacitor, 0.1uF Ceramic, 50V	AVX	08055C104K
C8	Capacitor, 0.1uF Ceramic, 50V	AVX	08055C104K
R1A,B	Resistor 10.0K, 1/8W, 0.01%		
R2A,B	Resistor 10.0K, 1/8W, 0.01%		