

MSK

M.S.KENNEDY CORP.

**HIGH SPEED
OPERATIONAL AMPLIFIER****0024**

4707 Dey Road Liverpool, N.Y. 13088

(315) 701-6751

FEATURES:

- Pin Similar Replacement for LH0024
- High Slew Rate: 400V/ μ S Typ.
- Fast Settling Time
- Excellent DC Performance
- Excellent Video Specifications
- Internally Compensated for Unity Gain Operation

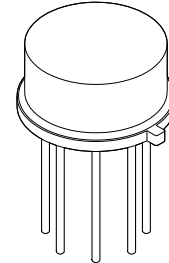
MIL-PRF-38534 QUALIFIED**DESCRIPTION:**

The MSK 0024 is a wide bandwidth, high slew rate operational amplifier ideally suited for use as a buffer to A to D and D to A converters and high speed comparators. The device is internally compensated and will remain stable when driving a capacitive load. The MSK 0024 is also a pin similar replacement for the popular LH0024. The MSK 0024 is internally compensated and can replace the LH0024 in most applications without any changes to existing circuitry. The device is packaged in a hermetically sealed 8 pin metal can.

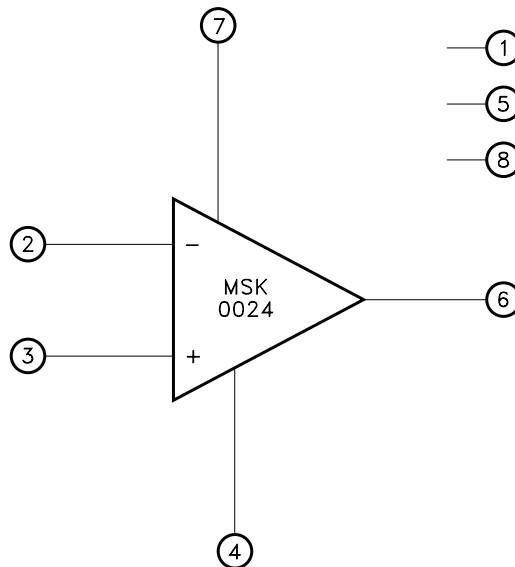
EQUIVALENT SCHEMATIC**TYPICAL APPLICATIONS**

- High Speed DAC Buffer
- High Speed Flash ADC Buffer
- High Speed Cable Driver
- Imaging Equipment

PIN-OUT INFORMATION

1 NC	8 NC
2 -Input	7 +Vcc
3 +Input	6 Output
4 -Vcc	5 NC

ABSOLUTE MAXIMUM RATINGS

V _{CC}	Supply Voltage	±18V	T _{ST}	Storage Temperature Range	-65°C to +150°C
P _D	Internal Power Dissipation	600mW	T _{LD}	Lead Temperature Range	300°C
V _{IN}	Input Voltage	±V _{CC} ≤ ±15V		(10 Seconds)	
V _{IND}	Differential Input Voltage	6V	T _J	Junction Temperature	175°C
T _C	Case Operating Temperature Range				
	MSK0024H/E	-55°C to +125°C			
	MSK0024	-40°C to +85°C			

ELECTRICAL SPECIFICATIONS

Parameter	Test Conditions	Group A	MSK0024H/E			MSK0024			Units
		Subgroup	Min.	Typ.	Max.	Min.	Typ.	Max.	
STATIC									
Supply Voltage Range ②		-	±5	±15	±18	±5	±15	±18	V
Quiescent Current		1	-	±6	±15	-	±6	±18	mA
		2,3	-	±6	±15	-	-	-	mA
INPUT									
Input Offset Voltage	AV = 5 RS = 50Ω	1	-	±0.5	±3.0	-	±0.5	±4.0	mV
		2,3	-	±1.0	±5.0	-	-	-	mV
Input Offset Voltage Drift ②		-	-	±15	-	-	±15	-	μV/°C
Input Bias Current ②	V _{CM} = 0V	1	-	±4	±20	-	±4	±30	μA
		2,3	-	±5	±30	-	-	-	μA
Input Offset Current ②	V _{CM} = 0V	1	-	±1	±5	-	±1	±10	μA
		2,3	-	±1	±5	-	-	-	μA
Common Mode Rejection Ratio ②	V _{CM} = ±10V _{DC}	1	75	95	-	75	95	-	dB
Power Supply Rejection Ratio ②	-V _{CC} = -15V +V _{CC} = +5V to +15V +V _{CC} = +15V -V _{CC} = -5V to -15V	1	75	95	-	75	95	-	dB
Input Impedance ②		-	-	300	-	-	300	-	KΩ
Input Capacitance ②		-	-	1.5	-	-	1.5	-	pF
OUTPUT									
Output Voltage Swing	R _L = 2KΩ	4	±12.0	±12.5	-	±12.0	±12.5	-	V
Power Bandwidth ②	V _{OUT} = ±10V _{PK} R _L = 2KΩ	-	-	4.5	-	-	4.5	-	MHz
TRANSFER CHARACTERISTICS									
Slew Rate	V _{OUT} = ±10V _{PK} R _L = 2KΩ	4	220	400	-	200	400	-	V/μS
Open Loop Voltage Gain ②	V _{OUT} = ±10V _{PK} f = 10Hz	4	3	8	-	3	8	-	V/mV
Thermal Resistance	Junction to Case @ 125°C	-	-	50	58	-	50	65	°C/W

NOTES:

- ① Unless otherwise specified, V_{CC} = ±15V_{DC} and V_{IN} = 0V.
- ② Guaranteed by design but not tested. Typical parameters are representative of actual device performance but are for reference only.
- ③ Industrial grade and "E" suffix devices shall be tested to subgroups 1 and 4 unless otherwise requested.
- ④ Military grade devices ("H" suffix) shall be 100% tested to subgroups 1,2,3 and 4.
- ⑤ Subgroup 5 and 6 testing available upon request.
- ⑥ Subgroup 1,4 T_C = +25°C
Subgroup 2,5 T_C = +125°C
Subgroup 3,6 T_A = -55°C

APPLICATION NOTES

POWER SUPPLY BYPASSING

Both the negative and positive power supplies must be effectively decoupled with a high and low frequency bypass circuit to avoid power supply induced oscillation. An effective decoupling scheme consists of a 0.1 microfarad ceramic capacitor in parallel with a 4.7 microfarad tantalum capacitor from each power supply pin to ground.

HEAT SINKING

To determine if a heat sink is necessary for your application and if so, what type, refer to the thermal model and governing equation below.

Thermal Model:

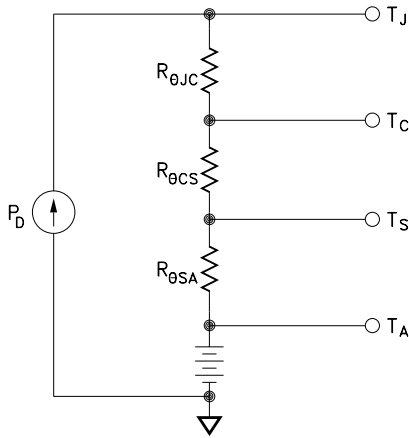

Governing Equation:

$$T_J = P_D \times (R_{\theta JC} + R_{\theta CS} + R_{\theta SA}) + T_A$$

Where

T_J	= Junction Temperature
P_D	= Total Power Dissipation
$R_{\theta JC}$	= Junction to Case Thermal Resistance
$R_{\theta CS}$	= Case to Heat Sink Thermal Resistance
$R_{\theta SA}$	= Heat Sink to Ambient Thermal Resistance
T_C	= Case Temperature
T_A	= Ambient Temperature
T_S	= Sink Temperature

Example:

The example demonstrates a worst case analysis for the op-amp output stage. This occurs when the output voltage is 1/2 the power supply voltage. Under this condition, maximum power transfer occurs and the output is under maximum stress.

Conditions:

$$V_{CC} = \pm 16\text{VDC}$$

$$V_{OUT} = \pm 8\text{Vp Sine Wave, Freq.} = 1\text{KHz}$$

$$R_L = 200\Omega$$

For a worst case analysis we treat the $\pm 8\text{Vp}$ sine wave as an 8 VDC output voltage.

- 1.) Find driver power dissipation

$$\begin{aligned} P_D &= (V_{CC} - V_{OUT}) (V_{OUT} / R_L) \\ &= (16\text{V} - 8\text{V}) (8\text{V} / 200\Omega) \\ &= 320\text{mW} \end{aligned}$$

- 2.) For conservative design, set $T_J = +125^\circ\text{C}$.

- 3.) For this example, worst case $T_A = +100^\circ\text{C}$.

- 4.) $R_{\theta JC} = 58^\circ\text{C/W}$ from MSK 032B Data Sheet.

- 5.) $R_{\theta CS} = 0.15^\circ\text{C/W}$ for most thermal greases.

- 6.) Rearrange governing equation to solve for $R_{\theta SA}$:

$$\begin{aligned} R_{\theta SA} &= ((T_J - T_A) / P_D) - (R_{\theta JC}) - (R_{\theta CS}) \\ &= (125^\circ\text{C} - 100^\circ\text{C}) / 0.32\text{W} - 58^\circ\text{C/W} - 0.15^\circ\text{C/W} \\ &= 78.1 - 58.15 \\ &= 19.9^\circ\text{C/W} \end{aligned}$$

The heat sink in this example must have a thermal resistance of no more than 19.9°C/W to maintain a junction temperature of less than $+125^\circ\text{C}$.

INPUT CONSIDERATIONS

An input resistor (R_{IN} below) is required in circuits where the input to the MSK0024 will be subjected to transient or continuous voltages exceeding the $\pm 6\text{V}$ maximum differential limit. This resistor will limit the current that can be forced into the bases of the input transistors.

FEEDBACK RESISTORS

Feedback resistors should be of low enough value ($< 5\text{K}$ recommended) to ensure that the time constant formed with the capacitance at the summing junction will not limit amplifier performance. If a larger resistor must be used, a small ($< 10\text{pF}$) feedback capacitor may be used in parallel with the feedback resistor to compensate and optimize the performance of the MSK0024.

TYPICAL APPLICATION CIRCUIT

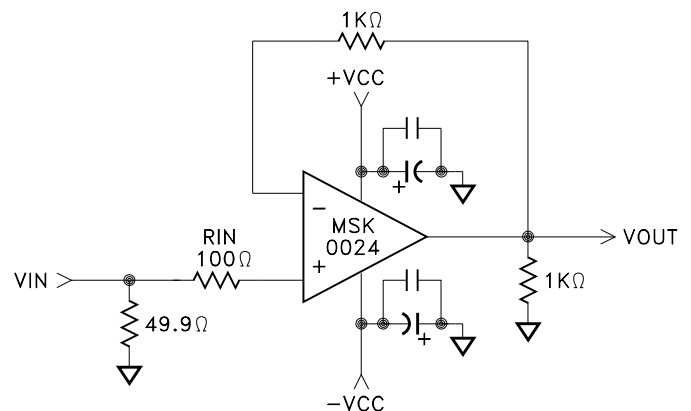

TYPICAL PERFORMANCE CURVES

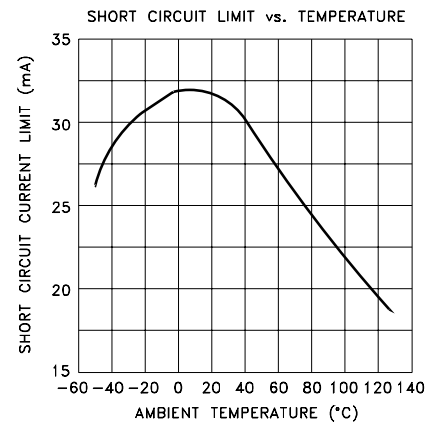
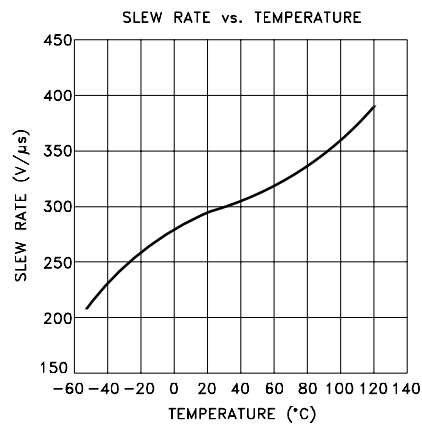
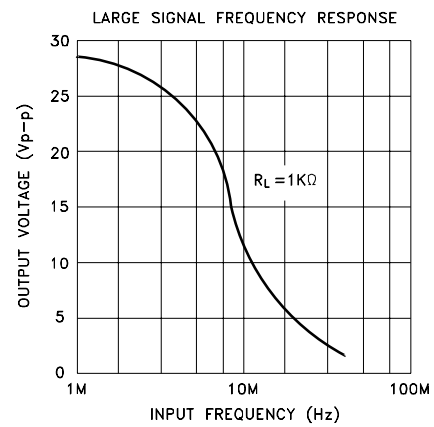
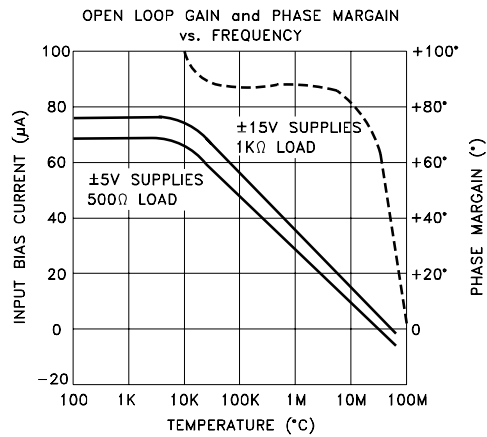
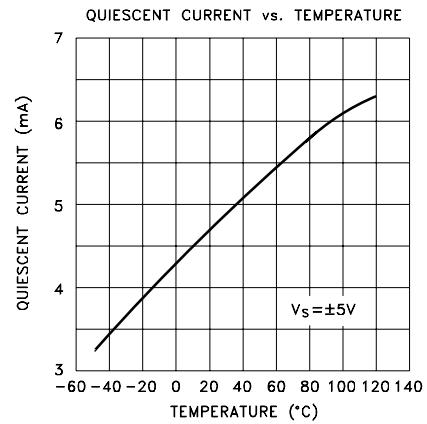
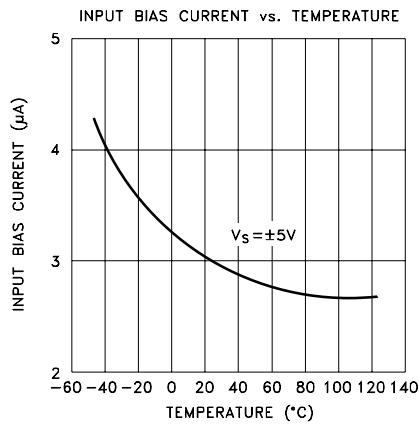
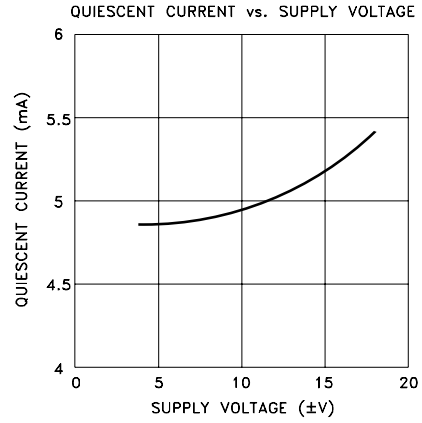
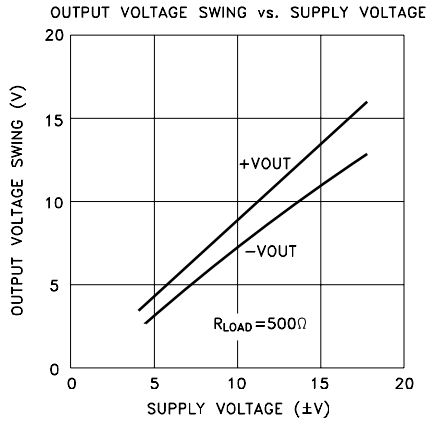

MECHANICAL SPECIFICATIONS

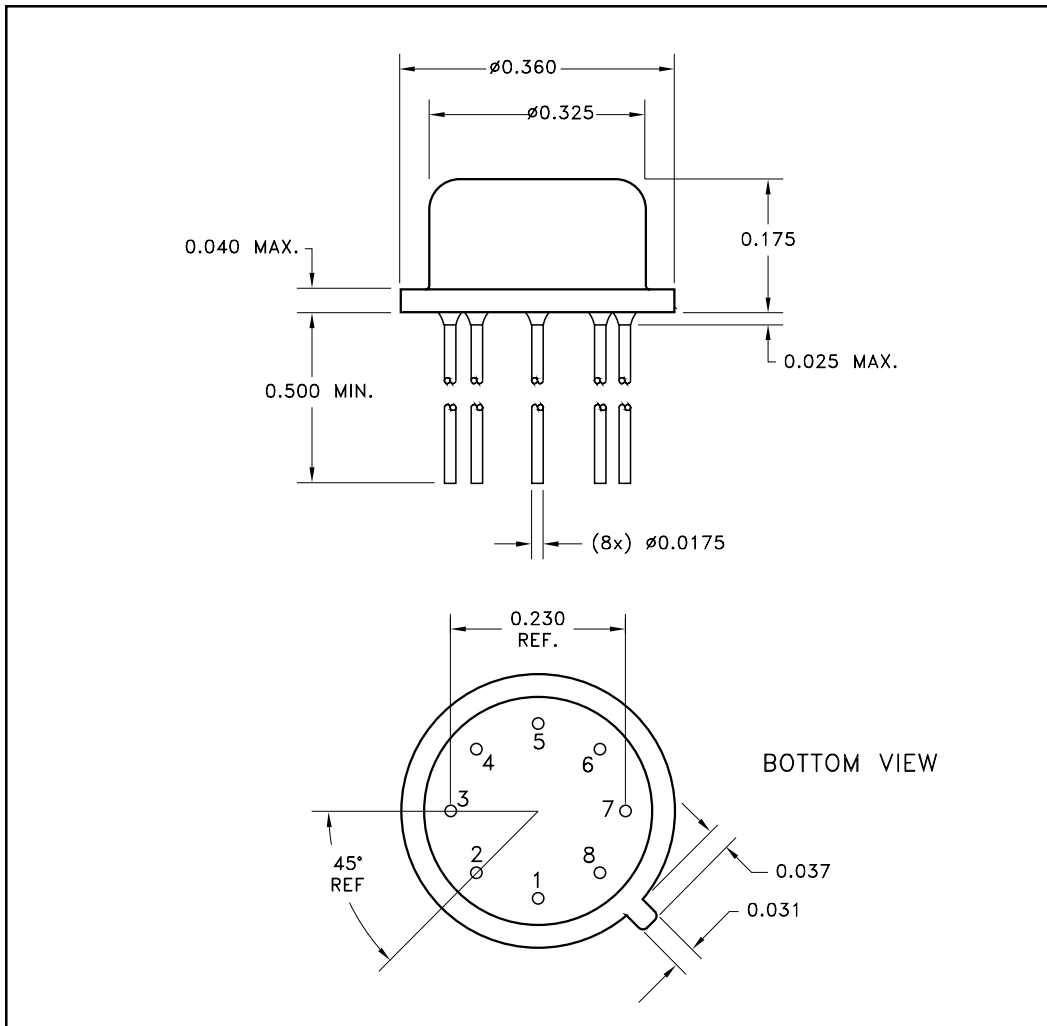

ALL DIMENSIONS ARE ± 0.010 INCHES UNLESS OTHERWISE LABELED.

ORDERING INFORMATION

MSK0024 H

SCREENING

BLANK = INDUSTRIAL; E = EXTENDED RELIABILITY

H = MIL-PRF-38534 CLASS H

GENERAL PART NUMBER

The above example is a Military grade hybrid.

M.S. Kennedy Corp.
 4707 Dey Road, Liverpool, New York 13088
 Phone (315) 701-6751
 FAX (315) 701-6752
 www.mskennedy.com

The information contained herein is believed to be accurate at the time of printing. MSK reserves the right to make changes to its products or specifications without notice, however, and assumes no liability for the use of its products. Please visit our website for the most recent revision of this datasheet.