



RAD HARD PRECISION RAIL TO RAIL CURRENT SENSE

197RH

FEATURES:

- Manufactured using  RH6105 Dice
- Radiation Hardened to 100 Krad(Si) (Method 1019.7 Condition A)
- Low Dose Rate Hardened to 50 Krad(Si) (Method 1019.7 Condition D)
- Neutron Tested to 5×10^{11} n/cm² (Method 1017.2)
- MIL-PRF-38534 Class H or K Screening Available
- Very Wide Input Common Mode Range
 - Extends 44V Above V- (Independent of V+)
 - Extends -0.3V Below V-
- Wide Power Supply Range: 2.85V to 36V
- Input Offset Voltage: 400 μ V Maximum
- Gain Accuracy: 1% Max
- Gain Configurable with External Resistors
- Operating Current: 195 μ A typ.
- Slew Rate: 2V/ μ s
- Full-Scale Output Current: 1mA Minimum
- Non-Rad Hard EDU's Available
- Available to DLA SMD 5962R13222
- Replaces MSK196RH
- MIL-PRF-38534 qualified

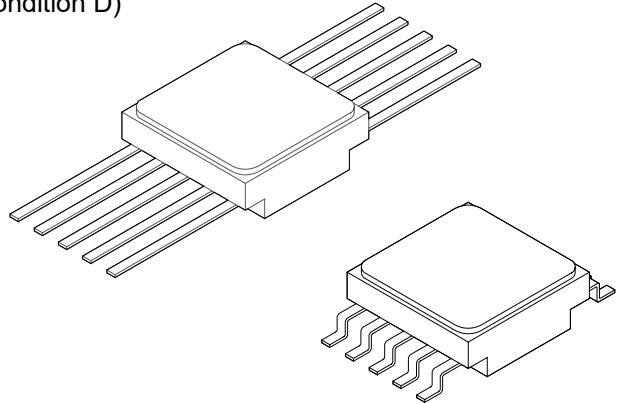

DESCRIPTION:

The MSK197RH is a radiation hardened precision micropower current sense amplifier with a very wide input common mode range. With Over-the-Top[®] Technology, the MSK197RH is capable of sensing in high side or low side applications. This combined with external gain setting, and common mode and power supply rejection in excess of 100dB, make the MSK197RH well suited for a variety of current sensing applications. The MSK197RH is hermetically sealed in a 10 pin ceramic flat pack, and is available with straight or gull wing lead form.

EQUIVALENT SCHEMATIC

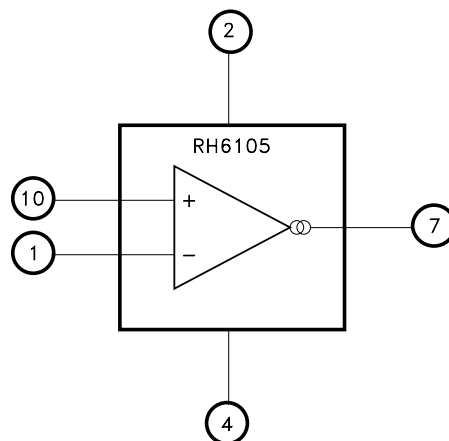

TYPICAL APPLICATIONS

- High Side or Low Side Current Sensing
- Current Monitoring on Positive or Negative Supply Voltages
- Battery Monitoring
- Fuse MOSFET Monitoring
- Power Management

PIN-OUT INFORMATION

1	-IN	10	+IN
2	V+	9	NC
3	NC	8	NC
4	V-	7	VOUT
5	NC	6	NC

CASE = ISOLATED

ABSOLUTE MAXIMUM RATINGS ^⑨

V _{IN}	Input Voltage (+IN, -IN to V-)	-9.5V to 44V
	Differential Input Voltage	44V
	Total Supply Voltage from V-	36V
V _{CC}	Output Short Circuit Duration	Indefinite

T _{ST}	Storage Temperature Range	-65°C to +150°C
T _{LD}	Lead Temperature Range (10 Seconds)	300°C
T _J	Junction Temperature	+150°C
T _C	Case Operating Temperature Range	
	MSK197K, HRH, KRH	-55°C to +125°C
	MSK197RH	-40°C to +85°C
	MSK197EDU	-40°C to +85°C
	ESD Rating	Class 1B

ELECTRICAL SPECIFICATIONS

Parameter	Test Conditions ^① ^⑩	Group A Subgroup	MSK 197K/HRH			MSK 197RH/EDU			Units	
			Min.	Typ.	Max.	Min.	Typ.	Max.		
Voltage Gain Error 1	V _{SENSE} = 25mV to 75mV	1	-1	0.1	1	-1	-	+1	%	
		2, 3	-1.5	0.1	1.5	-	-	-	%	
Voltage Gain Error 2	V _{SENSE} = 25mV to 75mV	1, 2, 3	-4.25	-	+2.25	-4.25	-	+2.25	%	
	V _S + = 0V Post Irradiation	1	-4.5	-	+4.5	-4.5	-	+4.5	%	
Input Offse Voltage 1	V _{SENSE} = 25mV; V _S + = 12V	1	-0.4	-0.1	0.4	-0.4	-0.1	0.4	mV	
		2, 3	-0.9	-	0.9	-	-	-	mV	
		Post Irradiation Condition A	1	-1.0	-	1.0	-1.0	-	1.0	mV
		Post Irradiation Condition D	1	-2.0	-	1.0	-2.0	-	1.0	mV
Input Offset Voltage 2	V _{SENSE} = 5mV; V _S + = 0V	1	-1	-0.3	1	-1	-0.3	1	mV	
		2, 3	-1.6	-	1.6	-	-	-	mV	
		Post Irradiation	1	-1.2	-	1.2	-1.2	-	1.2	mV
Input Common Mode Rejection Ratio	V _{SENSE} = 5mV; V _S + = 2.8V to 44V	4	100	120	-	100	120	-	dB	
		5, 6	95	-	-	-	-	-	dB	
		Post Irradiation	4	90	-	-	90	-	-	dB
Power Supply Rejection Ratio	V _{SENSE} = 5mV; V + = 2.85V to 36V	4	98	120	-	98	120	-	dB	
		5, 6	94	-	-	-	-	-	dB	
		Post Irradiation	4	90	-	-	90	-	-	dB
Input Current ^③	V _{SENSE} = 0V; V _S + = 3V; A _V = 25 V _{SENSE} = 0V; V _S + = 0V	1, 2, 3	-	18	30	-	18	30	μA	
		-	-	-0.05	-	-	-0.05	-	μA	
Input Offset Current ^③	V _{SENSE} = 0V; V _S + = 3V; A _V = 25 V _{SENSE} = 0V; V _S + = 0V	1, 2, 3	-	0.35	0.8	-	0.35	0.8	μA	
		-	-	0.1	-	-	0.1	-	μA	
V+ Supply Current	V _{SENSE} = 0V; V _S + = 3V; V + = 36V	1, 2, 3	-	195	450	-	195	450	μA	
Minimum Output Voltage	V _{SENSE} = 0mV; V _S + = 44V; V + = 36V	1	-	-	45	-	-	45	mV	
		2, 3	-	-	90	-	-	90	mV	
Output High (Referred to V +)	V _{SENSE} = 120mV; A _V = 100; R _{OUT} = 10K	1, 2, 3	-	1.3	1.7	-	1.3	1.7	V	
-3dB Bandwidth ^③	V _{SENSE} = 50mV; A _V = 100V/V	-	-	100	-	-	100	-	kHz	
Thermal Resistance ^②	Junction to Case @ 125°C	-	-	20.0	24.5	-	20.0	24.5	°C/W	

NOTES:

- ① Unless otherwise specified; V+=12V, V-=0V, V_S+ =12V, R_{IN1}=R_{IN2}=100W, R_{OUT}=5K(A_V = 50), V_{SENSE}=(V_S+)-(V_S-).
- ② Guaranteed by design but not tested.
- ③ Typical parameters are representative of device performance but are for reference only.
- ④ A heat sink may be required to keep the junction temperature below absolute maximum ratings.
- ⑤ Industrial grade devices shall be tested to subgroup 1 and 4 unless otherwise specified.
- ⑥ Military grade devices ("K, H" suffix) shall be 100% tested to subgroups 1,2,3, and 4
- ⑦ Subgroup 5 & 6 testing available upon request.
- ⑧ Subgroup 1,4 TC = +25°C
Subgroup 2,5 TC = +125°C
Subgroup 3,6 TC = -55°C
- ⑨ Continuous operation at or above absolute maximum ratings may adversely affect the device performance and/or life cycle.
- ⑩ Pre and post irradiation limits at 25°C, up to 100 Krad(Si) TID (Condition A) and 50 Krad(Si) TID (Condition D), are identical unless otherwise specified.
- ⑪ MSK197EDU does not use Rad Hard die, post irradiation specifications are not applicable.

APPLICATION NOTES

PIN FUNCTIONS

-IN - The -IN pin is the negative input terminal of the sense amplifier. Voltages as high as 44V can be applied to the pin, relative to the negative supply pin V-.

+IN - The +IN pin is the positive input terminal of the sense amplifier. Voltages as high as 44V can be applied to the pin, relative to the negative supply pin V-.

V+ - The V+ pin is the positive power supply for the device. Operational currents are sourced from this pin independent of the voltages on the -IN and +IN pins.

VOUT - The VOUT pin is the output of the amplifier. The voltage at the output is a function of both the input differential ($V_{SENSE} \pm VOS$), and the voltage gain R_{OUT}/R_{IN1} , for $R_{IN1} = R_{IN2}$. (See typical application ckt for more detail)

$$V_{OUT} = R_{OUT}/R_{IN} \times (V_{SENSE} \pm VOS)$$

Set $R_{IN1} = R_{IN2}$ for best accuracy

SENSE RESISTOR

Choose a R_{SENSE} resistor value just large enough to cover the application dynamic range to minimize power dissipation losses. The low $100\mu V$ typical offset voltage helps to maintain high resolution while minimizing power dissipation.

Kelvin connection of the input resistors to the sense resistor is recommended to minimize error in high current applications.

TYPICAL APPLICATION CKT

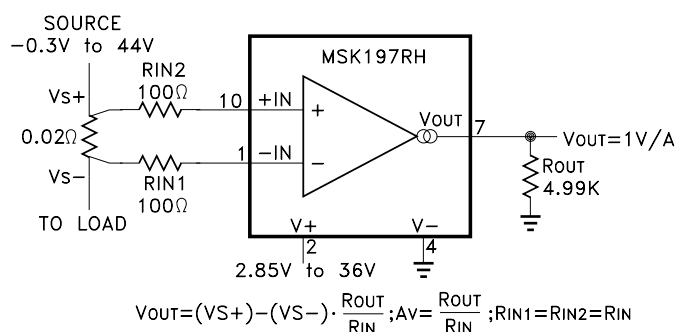

RADIATION TEST PERFORMANCE

Radiation performance curves have been generated for all radiation testing performed by TTM Technologies. These curves show performance trends throughout each test process and is located in the MSK197RH radiation test report. The complete radiation test report is available in the RAD HARD PRODUCTS section on the TTM Technologies website.

ADDITIONAL APPLICATION INFORMATION

For additional applications information, please reference Linear Technology Corporation's® LT6105 data sheet.

DEVICE ASSEMBLY

Due to the bond pad size, this device is manufactured with gold wirebonds.

For high voltage applications, the MSK197RH can be used with external MOSFETs. The MOSFETs protect the device from the full potential of the high voltage supply. The high voltage supply is the positive rail of the device, and the Zener voltage minus the $V_{GS(on)}$ potential of Q2 determines the negative voltage rail for the device; $(V-) = (V+) - (V_Z - V_{GS})$. The device can safely sense current from 0.3V below the negative rail up to 44V above it independent of high voltage supply, and deliver a ground referenced signal via Q1. The values in the application circuit are provided for reference. They may need to be adjusted based on specific application requirements.

HIGH VOLTAGE SIMPLE CURRENT MONITOR

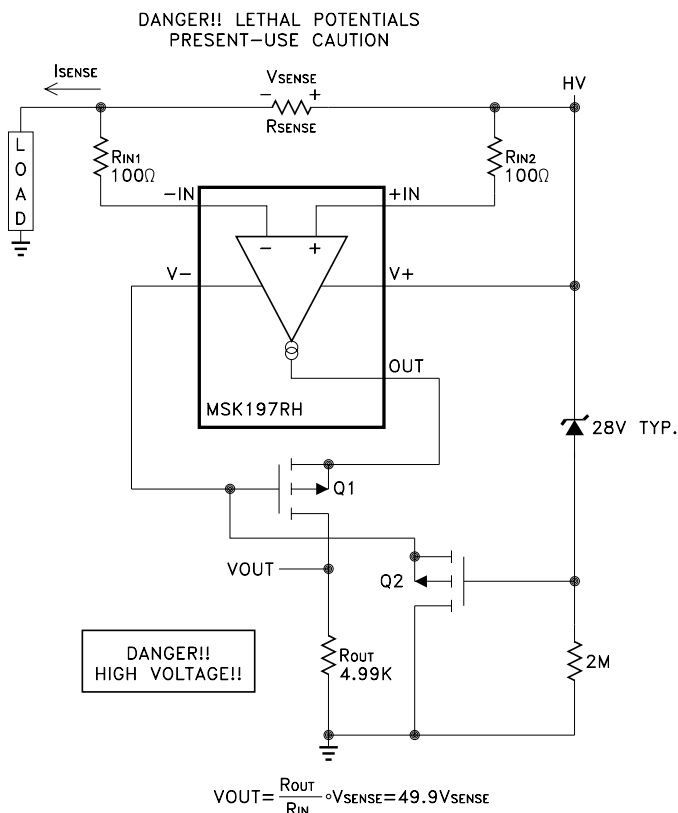

TYPICAL PERFORMANCE CURVES

GAIN ERROR vs INPUT VOLTAGE

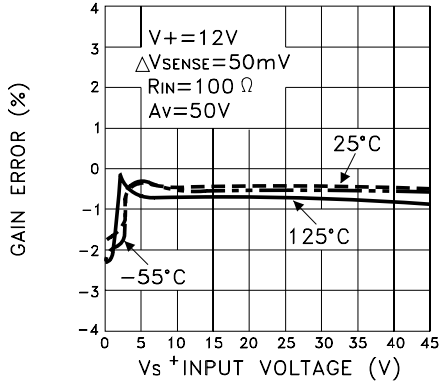

OUTPUT VOLTAGE vs V_{SENSE} VOLTAGE; $V_S = 0V$

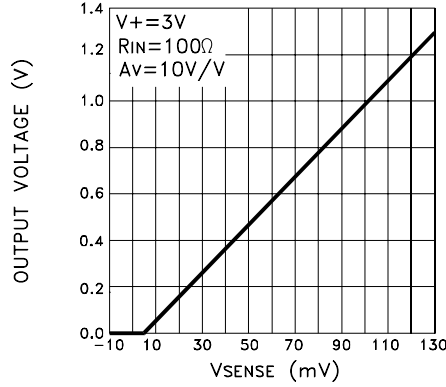

OUTPUT SATURATION VOLTAGE vs OUTPUT CURRENT $V_S = 12V$

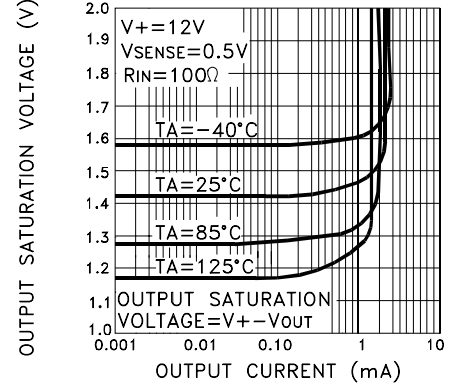

OUTPUT SATURATION VOLTAGE vs OUTPUT CURRENT $V_S = 0.5V$

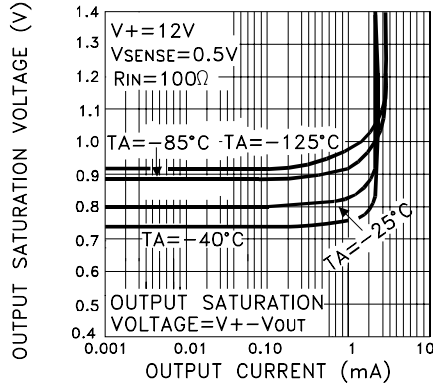

OUTPUT SHORT-CIRCUIT CURRENT vs TEMPERATURE

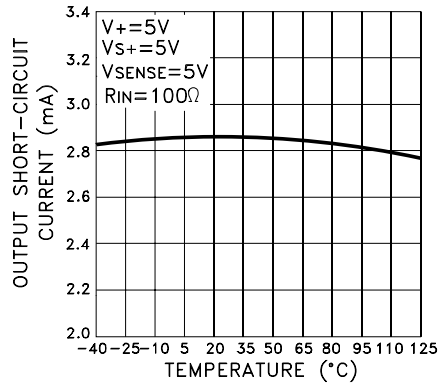

GAIN vs FREQUENCY

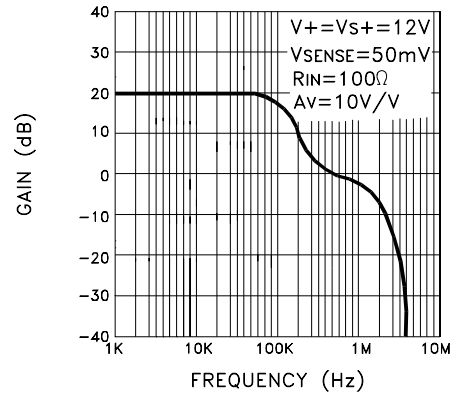

COMMON MODE REJECTION RATIO vs FREQUENCY

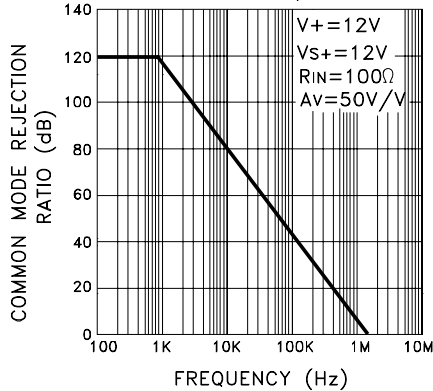

POWER SUPPLY REJECTION RATIO vs FREQUENCY

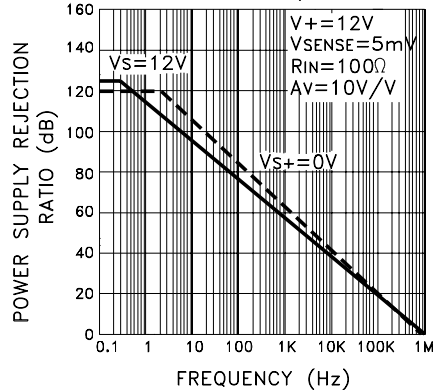

MECHANICAL SPECIFICATIONS

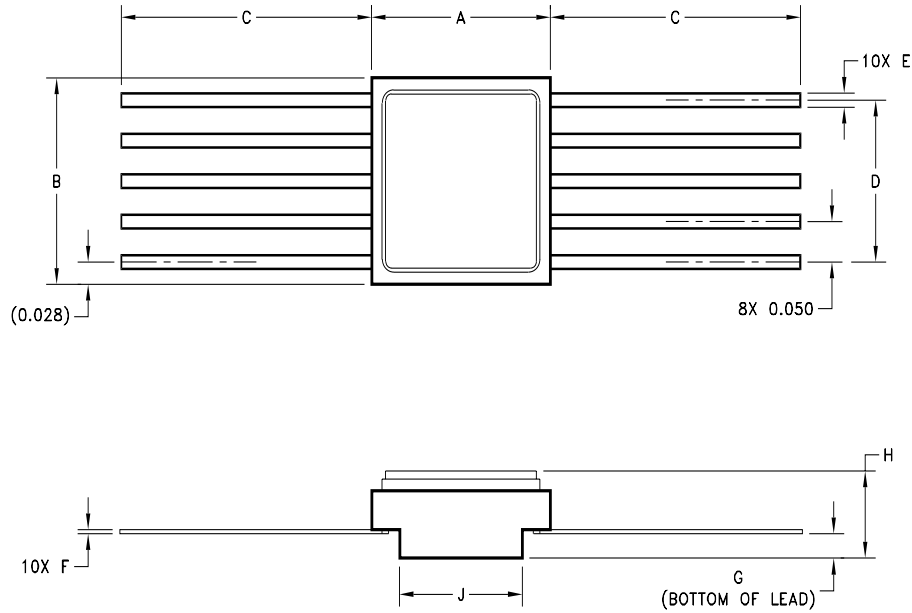

REF	MIN	MAX
A	0.245	0.265
B	0.245	0.265
C	0.250	
D	0.195	0.205
E	0.015	0.019
F	0.004	0.006
G	0.026	
H		0.115
J	0.170	0.180

ESD TRIANGLE INDICATES PIN 1
WEIGHT = 0.36 GRAMS TYPICAL

ALL DIMENSIONS ARE SPECIFIED IN INCHES

ORDERING INFORMATION

MSK197 K RH

LEAD CONFIGURATIONS

BLANK = STRAIGHT

RADIATION HARDENED

SCREENING

EDU = NON-RAD HARD ENG UNITS

BLANK = INDUSTRIAL; H = MIL-PRF38534 CLASS H;

K = MIL-PRF-38534 CLASS K

GENERAL PART NUMBER

The above example is a Class K screened device with straight leads.

NOTE: See DLA SMD 5962R13222 for DLA part number options.

MECHANICAL SPECIFICATIONS

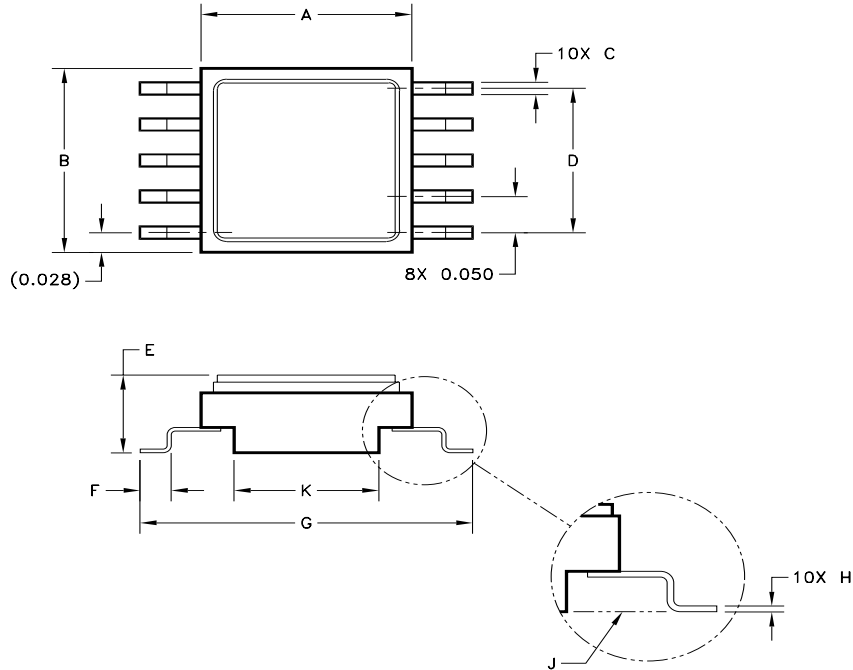

REF	MIN	MAX
A	0.245	0.265
B	0.245	0.265
C	0.015	0.019
D	0.195	0.205
E		0.115
F	0.0275	0.0475
G	0.390	0.415
H	0.004	0.006
J	-0.005	0.005
K	0.170	0.180

ESD TRIANGLE INDICATES PIN 1
WEIGHT = 0.3 GRAMS TYPICAL

ALL DIMENSIONS ARE SPECIFIED IN INCHES

ORDERING INFORMATION

MSK197 K RH G

LEAD CONFIGURATIONS

G = GULL WING

RADIATION HARDENED

SCREENING

EDU = NON-RAD HARD ENG UNITS

BLANK = INDUSTRIAL; H = MIL-PRF38534 CLASS H;

K = MIL-PRF-38534 CLASS K

GENERAL PART NUMBER

The above example is a Class K screened device with gull wing lead form.

NOTE: See DLA SMD 5962R13222 for DLA part number options.

REVISION HISTORY

REV	STATUS	DATE	DESCRIPTION
A	Released	05/17	Initial Release
B	Released	09/17	Add MSK 197VRH option
C	Released	02/20	Update qualification and SMD status
D	Released	12/21	Remove reference to MIL-PRF-38535 Class V, update company name and website
E	Released	09/23	Change Minimum Output Voltage Limits to Subgroups 2, 3

TTM Technologies
www.ttm.com

The information contained herein is believed to be accurate at the time of printing. TTM Technologies reserves the right to make changes to its products or specifications without notice, however and assumes no liability for the use of its products. Please visit our website for the most recent revision of this data sheet.