

HIGH CURRENT LOW DROPOUT VOLTAGE REGULATOR

5115

FEATURES:

- Electrically Isolated Top Tab or Z Tab SIP
- Extremely Low Dropout Voltage: 350mV @ 1.5 Amps
- Available Adjustable Version only
- TTL Level Enable Pin: Zero Current Shutdown Mode
- Reverse Battery and Load Dump Protection
- Low Ground Current: 22mA Typical at Full Load
- 1% Maximum Guaranteed Accuracy
- Output Current to 1.5 Amps

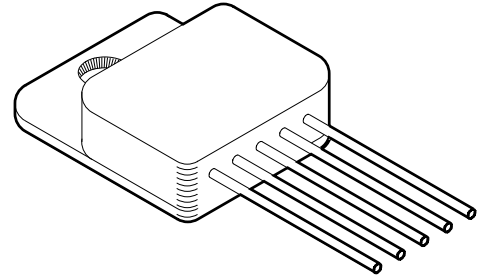

DESCRIPTION:

The MSK5115 voltage regulator is available in the adjustable output configuration only. The ultra low dropout specification is due to the utilization of a super PNP output pass transistor with monolithic technology. Dropout voltages of 350mV at 1.5 amps are typical in this configuration, which drives efficiency up and power dissipation down. The device also offers a TTL/CMOS compatible on/off enable function. The MSK5115 is packaged in a space efficient 5 pin power SIP available in two styles with three lead bend options.

EQUIVALENT SCHEMATIC

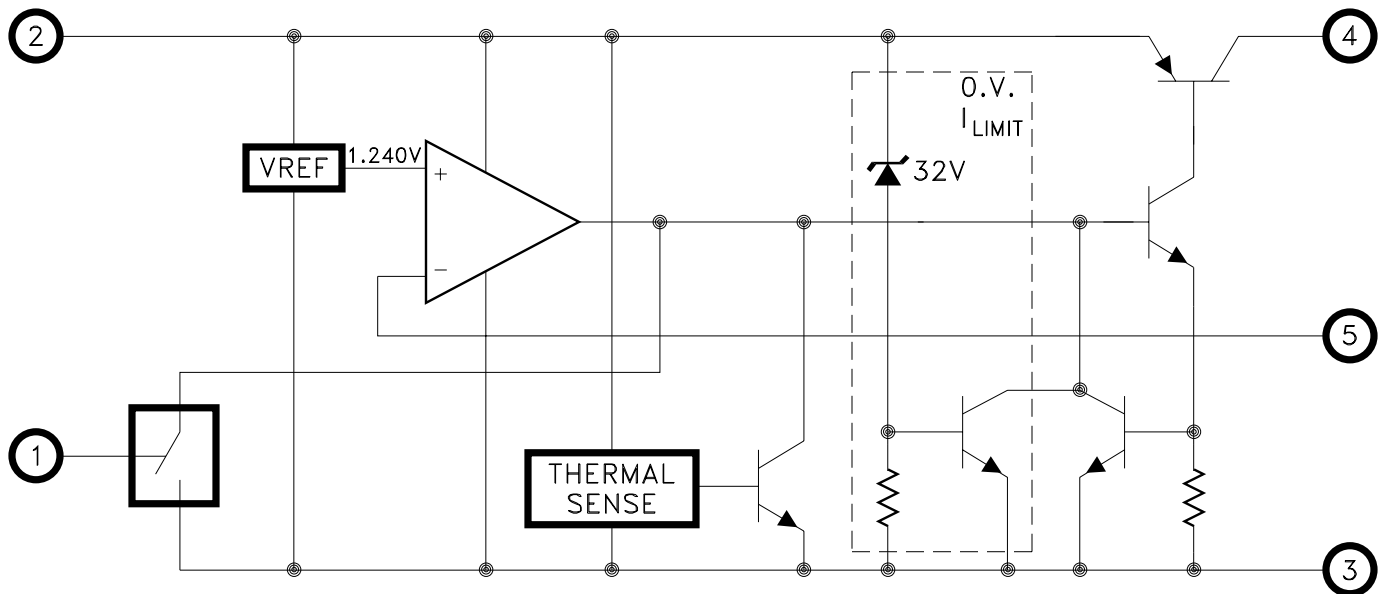

TYPICAL APPLICATIONS

- High Efficiency, High Current Linear Regulators
- Constant Voltage/Current Regulators
- System Power Supplies
- Switching Power Supply Post Regulators
- Battery Powered Equipment

PIN-OUT INFORMATION

MSK5115-00

- 1 ENABLE
- 2 VIN
- 3 GROUND
- 4 VOUT
- 5 VADJUST

CASE = ISOLATED

ABSOLUTE MAXIMUM RATINGS

⑨

V _{IN}	Input Voltage (100mS 1% D.C.)	-20V to +60V
V _{IN}	Input Voltage	26V
V _{EN}	Enable Voltage	-0.3V to 26V
I _{OUT}	Output Current	3.5A

T _{ST}	Storage Temperature Range	-65°C to +150°C
T _{LD}	Lead Temperature Range (10 Seconds Soldering)	300°C
T _C	Case Operating Temperature Range	
	MSK5115	-40°C to +85°C
	MSK5115B	-55°C to +125°C
	ESD Rating	Class 1B

ELECTRICAL SPECIFICATIONS

Parameter	Test Conditions ① ③	Group A Subgroup	MSK5115B SERIES			MSK5115 SERIES			Units
			Min.	Typ.	Max.	Min.	Typ.	Max.	
Reference Voltage	Normal Operation	1	1.22	1.24	1.26	1.22	1.24	1.26	V
		2, 3	1.21	-	1.27	1.21	-	1.27	V
Dropout Voltage ②	$\Delta V_{OUT} = -1\%$; I _{OUT} = 100mA	1	-	80	200	-	80	225	mV
	$\Delta V_{OUT} = -1\%$; I _{OUT} = 1.5A	1	-	350	600	-	350	625	mV
Load Regulation ⑧	V _{IN} = V _{OUT} +1V 10mA ≤ I _{OUT} ≤ 1.25A	1	-	±0.2	±1.0	-	±0.2	±1.2	%
		2, 3	-	±0.3	±2.0	-	±0.3	-	%
Line Regulation	(V _{OUT} +1V) ≤ V _{IN} ≤ 26V I _{OUT} = 10mA	1	-	±0.05	±0.5	-	±0.05	±0.6	%
		2, 3	-	±0.5	±1.0	-	±0.5	-	%
Output Current Limit ②	V _{OUT} = 0V; V _{IN} = V _{OUT} +1V	-	-	2.1	3.5	-	2.1	3.5	A
Ground Current ②	V _{IN} = V _{OUT} +1V; I _{OUT} = 0.75A	-	-	8	20	-	8	20	mA
	V _{IN} = V _{OUT} +1V; I _{OUT} = 1.5A	-	-	22	-	-	22	-	mA
Output Noise ②	C _L = 10uF; 10Hz ≤ f ≤ 100KHz	-	-	400	-	-	400	-	uA
Enable Input Voltage ②	HIGH/ON	1	2.4	1.2	-	2.4	1.2	-	V
	LOW/OFF	1	-	1.2	0.8	-	1.2	0.8	V
Enable Input Current ②	HIGH/ON	1	-	100	600	-	100	600	uA
	LOW/OFF	1	-	-	2	-	-	2	uA
Shutdown Output Current ②	V _{ENABLE} ≤ 0.8V	-	-	10	500	-	10	500	uA
Reference Voltage Temp Drift ②	Normal Operation	-	-	20	-	-	20	-	ppm/°C
Adjust Pin Bias Current ②	Full Temp; V _{IN} = V _{OUT} +1V	-	-	40	120	-	40	150	nA
Thermal Resistance ②	Junction to Case @ 125°C	-	-	3.1	3.6	-	3.1	3.7	°C/W
Thermal Shutdown ②	T _J	-	-	130	-	-	130	-	°C

NOTES:

- ① Output decoupled to ground using 28μF minimum capacitance unless otherwise specified.
- ② This parameter is guaranteed by design but need not be tested.
Typical parameters are representative of actual device performance but are for reference only
- ③ All output parameters are tested using a low duty cycle pulse to maintain T_J = T_C.
- ④ Industrial grade devices shall be tested to subgroup 1 unless otherwise specified.
- ⑤ Military grade devices ('B' suffix) shall be 100% tested to subgroups 1, 2, 3.
- ⑥ Subgroup 1 T_C = +25°C
Subgroup 2 T_J = +125°C
Subgroup 3 T_A = -55°C
- ⑦ Please consult the factory if alternate output voltages are required.
- ⑧ Due to current limit, maximum output current may not be available at all values of V_{IN}-V_{OUT} and temperatures. See typical performance curves for clarification.
- ⑨ Continuous operation at or above absolute maximum ratings may adversely effect the device performance and/or life cycle.
- ⑩ Internal solder reflow temperature is 180°C, do not exceed.

APPLICATION NOTES

REGULATOR PROTECTION

The MSK5115 is fully protected against reversed input polarity, overcurrent faults, overtemperature conditions (Pd) and transient voltage spikes of up to 60V. If the regulator is used in dual supply systems where the load is returned to a negative supply, the output voltage must be diode clamped to ground.

OUTPUT CAPACITOR

The output voltage ripple of the MSK5115 voltage regulator can be minimized by placing a filter capacitor from the output to ground. The optimum value for this capacitor may vary from one application to the next, but a minimum of 10µF is recommended for optimum performance. This capacitor need not be an expensive low ESR type: aluminum electrolytics are adequate. In fact, extremely low ESR capacitors may contribute to instability. Tantalum capacitors are recommended for systems where fast load transient response is important. Transient load response can also be improved by placing a capacitor directly across the load.

LOAD CONNECTIONS

In voltage regulator applications where very large load currents are present, the load connection is very important. The path connecting the output of the regulator to the load must be extremely low impedance to avoid affecting the load regulation specifications. Any impedance in this path will form a voltage divider with the load. The MSK5115 requires a minimum of 10mA of load current to stay in regulation.

ENABLE PIN

The MSK 5115 of voltage regulator is equipped with a TTL compatible ENABLE pin. A TTL high level on this pin activates the internal bias circuit and powers up the device. A TTL low level on this pin places the controller in shutdown mode and the device draws approximately 10µA of quiescent current. If the enable function is not used, simply connect the enable pin to the input.

DEVICE/CASE CONNECTION

The MSK5115 is a highly thermally conductive device, and the thermal path from the package heat sink to the internal junction is very short. Since the case is electrically isolated from the internal circuitry, the package can be directly connected to a heat sink.

HEAT SINK SELECTION

To select a heat sink for the MSK5115, the following formula for convective heat flow may be used.

Governing Equation:

$$T_j = P_d \times (R_{\theta jc} + R_{\theta cs} + R_{\theta sa}) + T_a$$

WHERE:

T_j = Junction Temperature

P_d = Total Power Dissipation

R_{θjc} = Junction to Case Thermal Resistance

R_{θcs} = Case to Heat Sink Thermal Resistance

R_{θsa} = Heat Sink to Ambient Thermal Resistance

T_a = Ambient Temperature

First, the power dissipation must be calculated as follows:

$$\text{Power Dissipation} = (V_{IN} - V_{OUT}) \times I_{out}$$

Next, the user must select a maximum junction temperature. The absolute maximum allowable junction temperature is 125°C. The equation may now be rearranged to solve for the required heat sink to ambient thermal resistance (R_{θsa}).

EXAMPLE:

An MSK5115 is configured for V_{IN}=+5V and V_{OUT}=+3.3V. I_{out} is a continuous 1A DC level. The ambient temperature is +25°C. The maximum desired junction temperature is 125°C.

R_{θjc} = 3.6°C/W and R_{θcs} = 0.15°C/W for most thermal greases

$$\begin{aligned} \text{Power Dissipation} &= (5V - 3.3V) \times (1A) \\ &= 1.7 \text{ Watts} \end{aligned}$$

Solve for R_{θsa}:

$$\begin{aligned} R_{\theta sa} &= \left[\frac{125^\circ\text{C} - 25^\circ\text{C}}{1.7\text{W}} \right] - 3.6^\circ\text{C/W} - 0.15^\circ\text{C/W} \\ &= 55.07^\circ\text{C/W} \end{aligned}$$

In this example, a heat sink with a thermal resistance of no more than 55°C/W must be used to maintain a junction temperature of no more than 125°C.

MSK5115-00 OUTPUT ADJUSTMENT

The diagram below illustrates proper adjustment technique for the output voltage. The series resistance of R₁+R₂ should be selected to pass the minimum regulator output current requirement of 10mA.

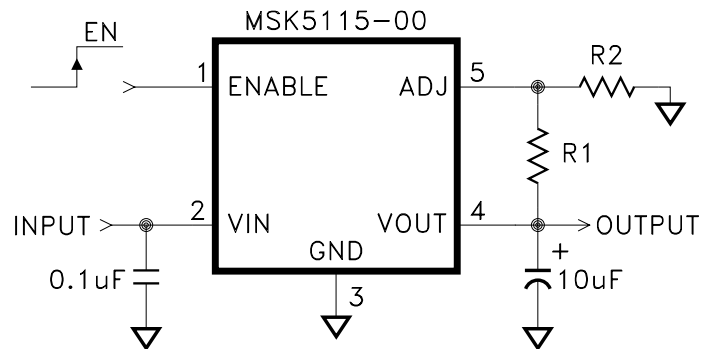

$$V_{OUT} = 1.240V \times \left[1 + (R_1/R_2) \right]$$

TYPICAL PERFORMANCE CURVES

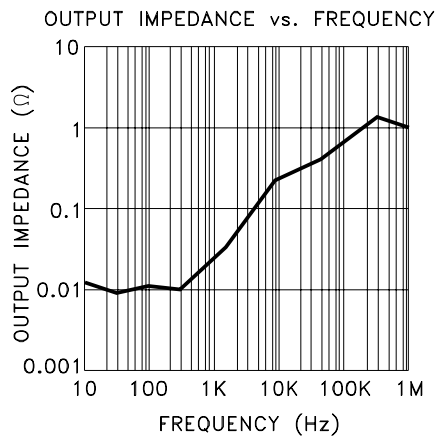
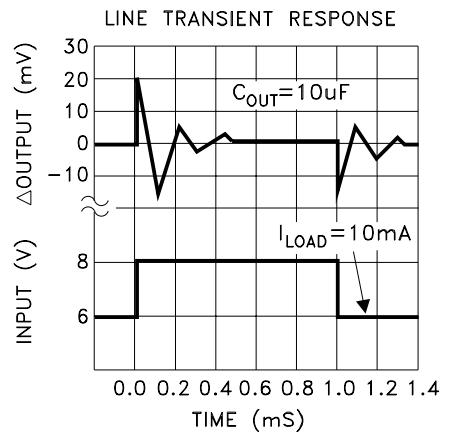
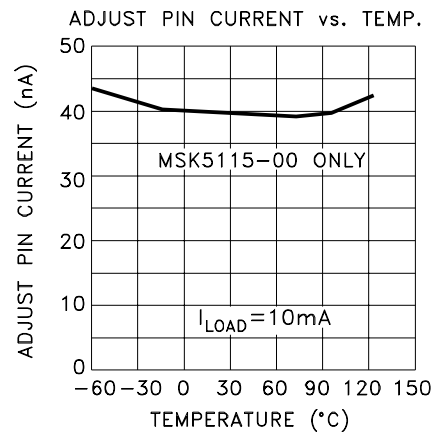
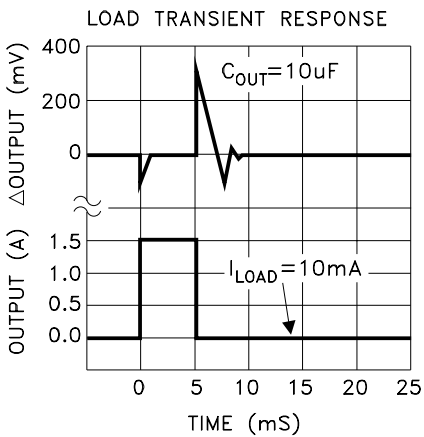
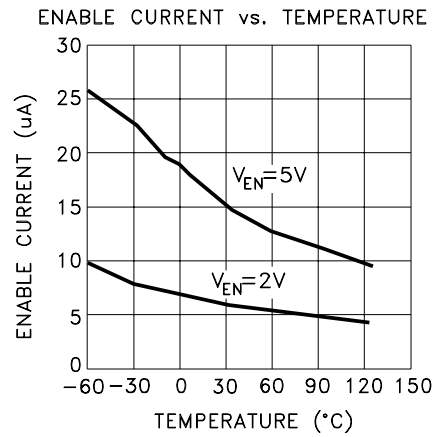
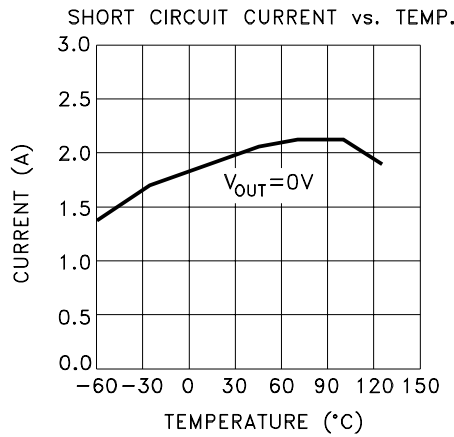
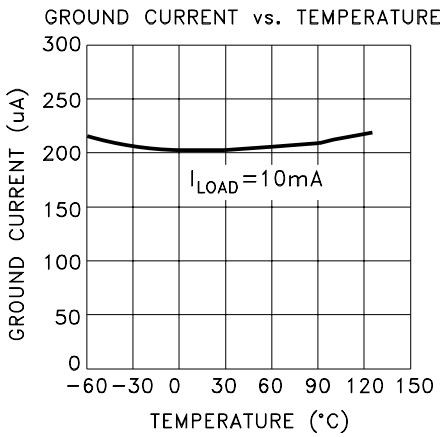
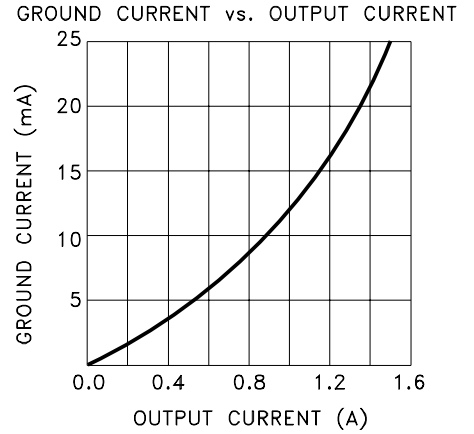
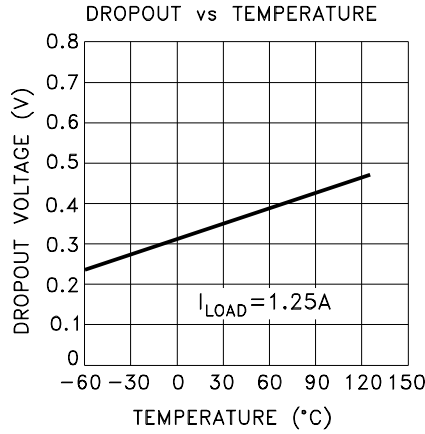
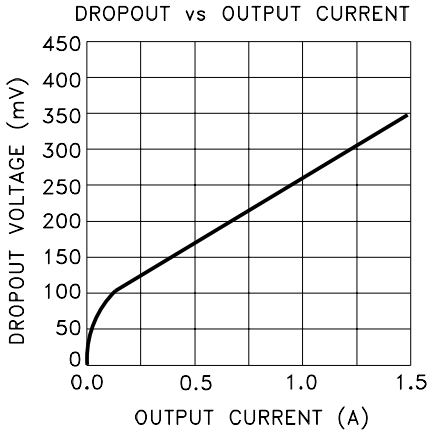

MECHANICAL SPECIFICATIONS

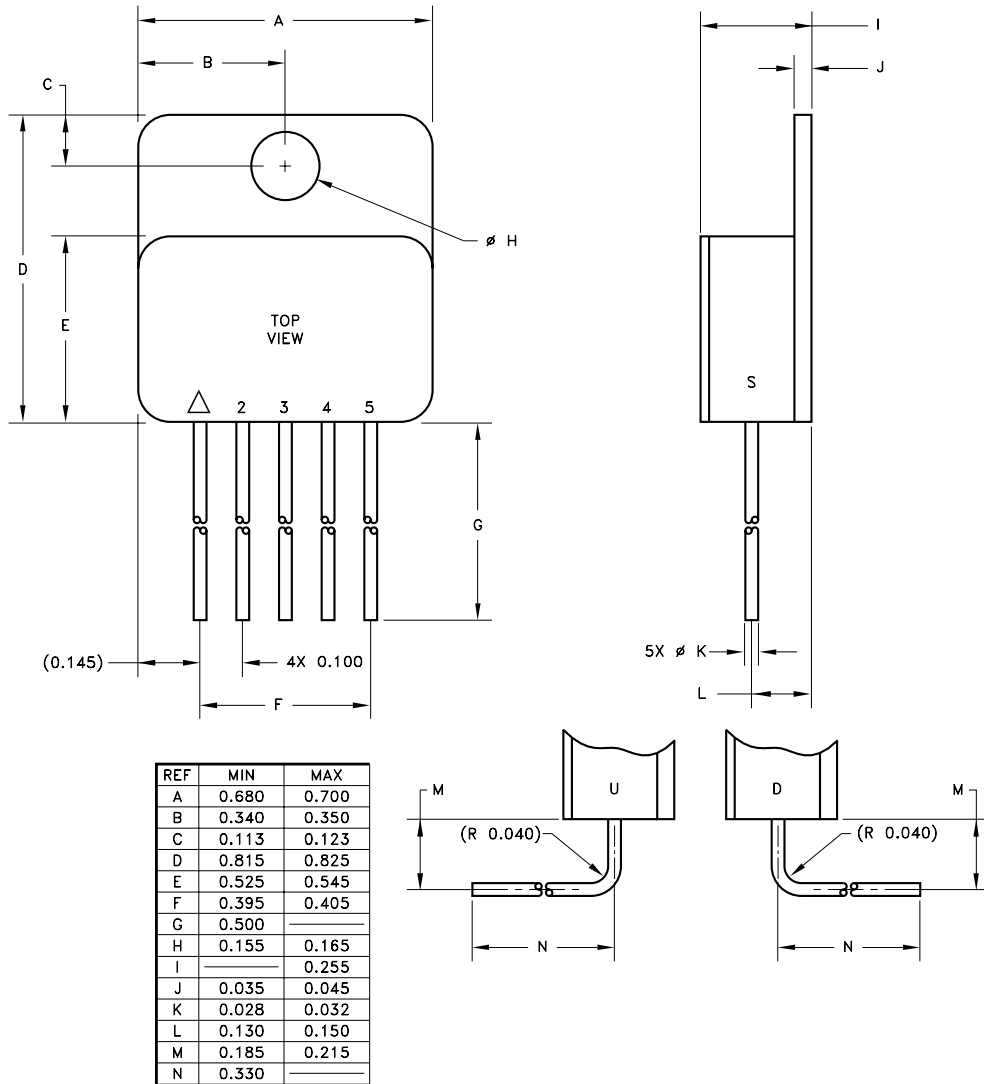

ESD TRIANGLE INDICATES PIN 1
 WEIGHT = 7.7 GRAMS TYPICAL

ALL DIMENSIONS ARE SPECIFIED IN INCHES

ORDERING INFORMATION

MSK5115-00 B T U

- GENERAL PART NUMBER
 - OUTPUT VOLTAGE
 - SCREENING
 - PACKAGE STYLE
 - LEAD CONFIGURATIONS
- 00 = ADJ
 BLANK = INDUSTRIAL; B = MIL-PRF 38534 CLASS H
 T = TOP TAB
 S = STRAIGHT; U = BENT UP; D = BENT DOWN

MECHANICAL SPECIFICATIONS CONT'D

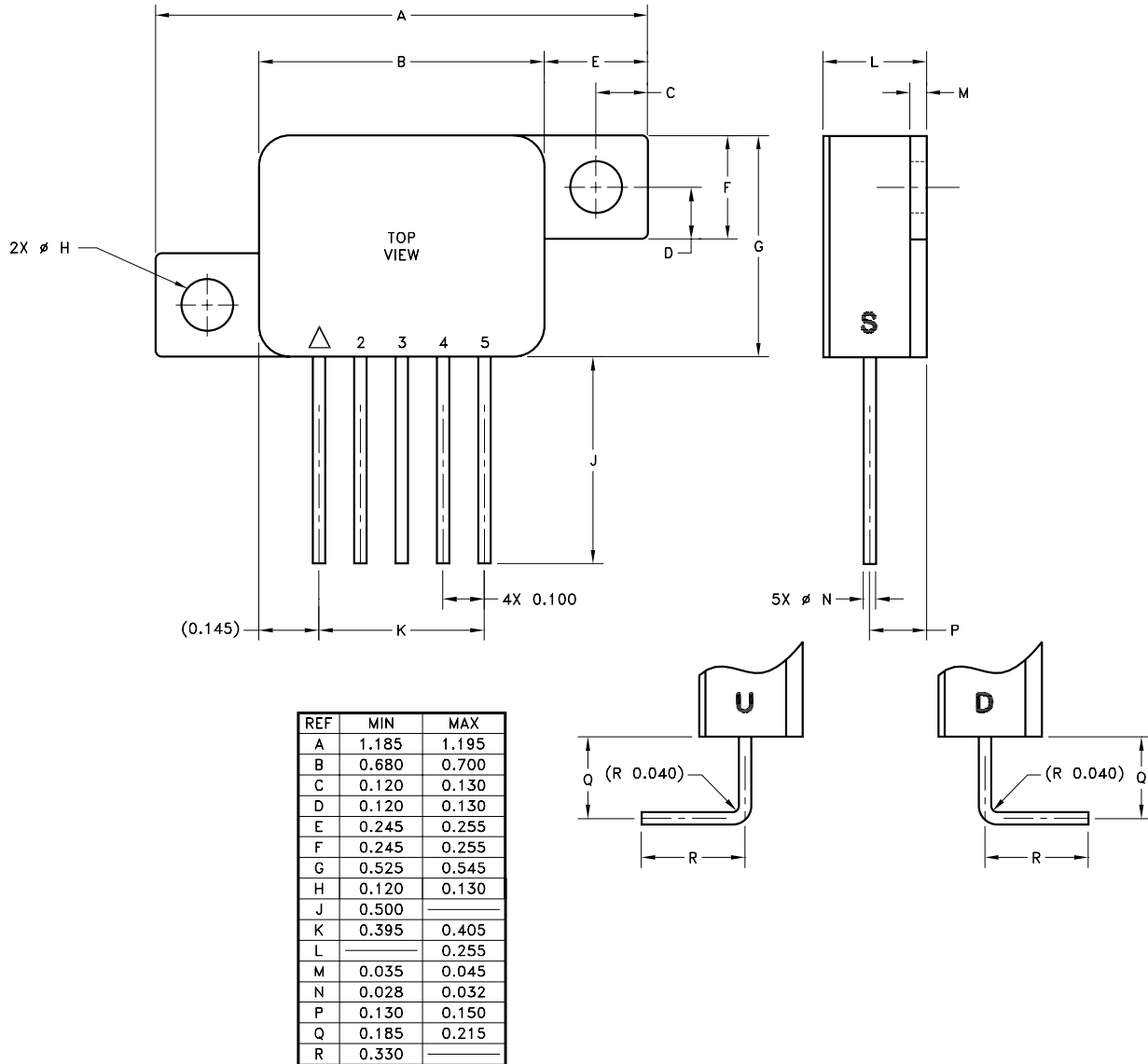

ESD TRIANGLE INDICATES PIN 1
WEIGHT = 8.1 GRAMS TYPICAL

ALL DIMENSIONS ARE SPECIFIED IN INCHES

ORDERING INFORMATION

MSK5115-00 B Z U

LEAD CONFIGURATIONS

S = STRAIGHT; U = BENT UP; D = BENT DOWN

PACKAGE STYLE

Z = Z PACK

SCREENING

BLANK = INDUSTRIAL; B = MIL-PRF 38534 CLASS H

OUTPUT VOLTAGE

00 = ADJ

GENERAL PART NUMBER

REVISION HISTORY

REV	STATUS	DATE	DESCRIPTION
K	Released	07/15	Add ESD rating to absolute maximum ratings and update format.
L	Released	01/23	Remove MIL-PRF-38535, update company name and website.

TTM Technologies

www.ttm.com

The information contained herein is believed to be accurate at the time of printing. TTM Technologies reserves the right to make changes to its products or specifications without notice, however and assumes no liability for the use of its products. Please visit our website for the most recent revision of this data sheet.