

MSK

M.S.KENNEDY CORP.

**NEGATIVE, 3 AMP,
LOW DROPOUT
VOLTAGE REGULATOR****5330
SERIES**

4707 Dey Road Liverpool, N.Y. 13088

(315) 701-6751

FEATURES:

- -5V, -5.2V, -10V, -12V and -15V Standard Versions
- Low Dropout Voltage
- Output Current to 3 Amps
- Output Voltage Internally Set to $\pm 1\%$ MAX.
- Internal Short Circuit Current Limit
- Internal Thermal Overload Protection
- Hermetic Surface Mount Package
- Alternate Output Voltages Available

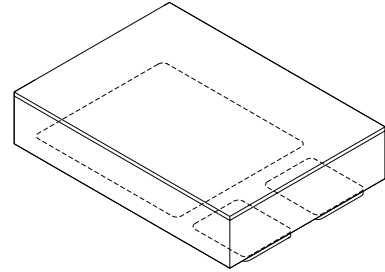
MIL-PRF-38534 CERTIFIED**DESCRIPTION:**

The MSK 5330 is a fixed, negative voltage regulator which offers low dropout and output voltage accuracy to $\pm 1\%$ maximum. The low θ_{jc} combined with low dropout allows increased output current and excellent device efficiency. The MSK 5330 offers both internal current limit and thermal overload protection. The device is packaged in a space efficient 3 pin power surface mount ceramic package.

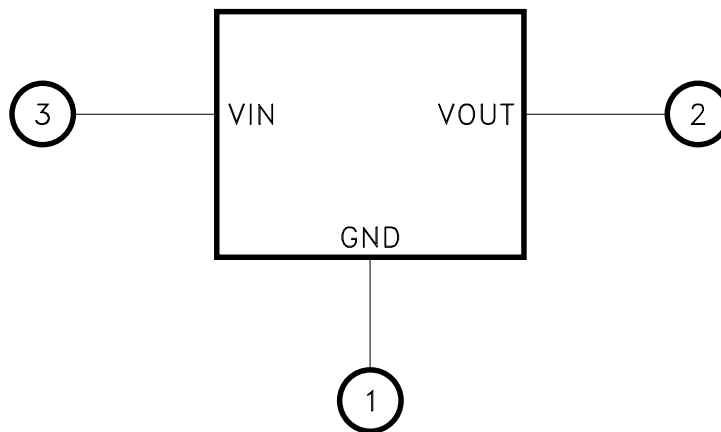
EQUIVALENT SCHEMATIC**TYPICAL APPLICATIONS**

- High Efficiency Linear Regulators
- Constant Voltage/Current Regulators
- System Power Supplies
- Switching Power Supply Post Regulators

PIN-OUT INFORMATION

- 1 GND
- 2 VOUT
- 3 VIN

ABSOLUTE MAXIMUM RATINGS

⑨

$-V_{IN}$	Input Voltage (WRT V_{OUT})	-30V	T_{ST}	Storage Temperature Range	-65°C to +150°C
P_D	Power Dissipation	Internally Limited	T_{LD}	Lead Temperature Range	300°C
I_{OUT}	Output Current	-3A		(10 Seconds)	
T_J	Junction Temperature	+175°C	T_C	Case Operating Temperature	
				MSK 5330H/E	-55°C to +125°C
				MSK 5330	-40°C to +85°C

ELECTRICAL SPECIFICATIONS

Parameter	Test Conditions ③	Group A	MSK 5330H/E			MSK 5330			Units
		Subgroup	Min.	Typ.	Max.	Min.	Typ.	Max.	
Output Voltage Tolerance	$I_{OUT} = 10mA$; $V_{IN} = V_{OUT} + 3V$	1	-	0.1	1.0	-	0.1	2.0	%
		2,3	-	0.1	2.0	-	-	-	%
Dropout Voltage ②	$0A \leq I_{OUT} \leq 3A$; $\Delta V_{OUT} = 1\%$	1	-	0.8	1.2	-	0.8	1.3	V
Load Regulation	$100mA \leq I_{OUT} \leq 3A$ $V_{IN} = V_{OUT} + 3V$	1	-	0.2	1.0	-	0.2	2.0	%
		2,3	-	0.3	2.0	-	-	-	%
Line Regulation	$I_{OUT} = 10mA$ $(V_{OUT} + 3V) \leq V_{IN} \leq (V_{OUT} + 15V)$	1	-	0.1	0.5	-	0.1	0.6	%
		2,3	-	0.2	0.75	-	-	-	%
Quiescent Current	$V_{IN} = V_{OUT} + 3V$; $I_{OUT} = 0A$	1,2,3	-	4.5	10	-	4.5	10	mA
Short Circuit Current ②	$V_{IN} = V_{OUT} + 5V$	-	3.3	3.6	-	3.0	3.6	-	A
Ripple Rejection ②	$I_{OUT} = 3A$; $C_{OUT} = 25\mu F$; $f = 120Hz$	-	60	75	-	60	75	-	dB
Thermal Resistance ②	JUNCTION TO CASE @ 125°C	-	-	4.2	4.6	-	4.2	5.0	°C/W
Thermal Shutdown	T_J	-	-	150	-	-	150	-	°C

PART NUMBER ⑦	OUTPUT VOLTAGE
MSK5330-5.0	-5.0V
MSK5330-5.2	-5.2V
MSK5330-10	-10.0V
MSK5330-12	-12.0V
MSK5330-15	-15.0V

NOTES:

- ① Output is decoupled to ground using 33 μF minimum, low ESR capacitors unless otherwise specified.
- ② Guaranteed by design but not tested. Typical parameters are representative of actual device performance but are for reference only.
- ③ All output parameters are tested using a low duty cycle pulse to maintain $T_J = T_C$.
- ④ Industrial grade and "E" suffix devices shall be tested to subgroup 1 unless otherwise specified.
- ⑤ Military grade devices ("H" suffix) shall be 100% tested to subgroups 1,2 and 3.
- ⑥ Subgroup 1 $T_A = T_C = +25^\circ C$
2 $T_A = T_C = +125^\circ C$
3 $T_A = T_C = -55^\circ C$
- ⑦ Please consult the factory if alternate output voltages are required.
- ⑧ Input voltage ($V_{IN} = V_{OUT} +$ a specified voltage) is implied to be more negative than V_{OUT} .
- ⑨ Continuous operation at or above absolute maximum ratings may adversely effect the device performance and/or life cycle

APPLICATION NOTES

BYPASS CAPACITORS

For most applications a 33uF minimum, low ESR (0.5-2 ohm) tantalum capacitor should be attached as close to the regulator's output as possible. This will effectively lower the regulator's output impedance, increase transient response and eliminate any oscillations that are normally associated with low dropout regulators. Additional bypass capacitors can be used at the remote load locations to further improve regulation. These can be either of the tantalum or the electrolytic variety. Unless the regulator is located very close to the power supply filter capacitor(s), a 4.7uF minimum low ESR (0.5-2 ohm) tantalum capacitor should also be added to the regulator's input. An electrolytic may also be substituted if desired. When substituting electrolytic in place of tantalum capacitors, a good rule of thumb to follow is to increase the size of the electrolytic by a factor of 10 over the tantalum value.

LOAD REGULATION

For best results the ground pin should be connected directly to the load as shown below, this effectively reduces the ground loop effect and eliminates excessive voltage drop in the sense leg. It is also important to keep the output connection between the regulator and the load as short as possible since this directly affects the load regulation. For example, if 20 gauge wire were used which has a resistance of about .008 ohms per foot, this would result in a drop of 8mV/ft at 1Amp of load current. It is also important to follow the capacitor selection guidelines to achieve best performance. Refer to Figure 1 for connection diagram.

MSK 5330 TYPICAL APPLICATION:

Low Dropout Negative Power Supply

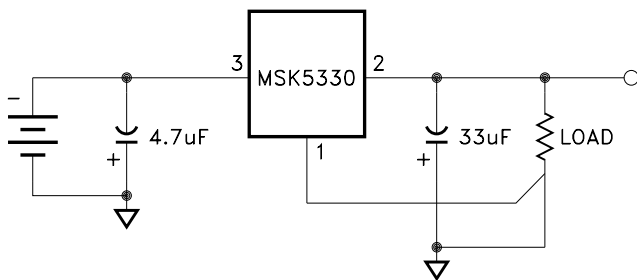

FIGURE 1

OVERLOAD SHUTDOWN

The MSK 5330 features both power and thermal overload protection. When the maximum power dissipation is not exceeded, the regulator will current limit slightly above its 3 amp rating. As the $V_{in}-V_{out}$ voltage increases, however, shutdown occurs in relation to the maximum power dissipation curve. If the device heats enough to exceed its rated die junction temperature due to excessive ambient temperature, improper heat sinking etc., the regulator will shutdown until an appropriate junction temperature is maintained. It should also be noted that in the case of an extreme overload, such as a sustained direct short, the device may not be able to recover. In these instances, the device must be shut off and power reapplied to eliminate the shutdown condition.

HEAT SINKING

To determine if a heat sink is required for your application and if so, what type, refer to the thermal model and governing equation below.

Governing Equation: $T_j = P_d \times (R_{\theta jc} + R_{\theta cs} + R_{\theta sa}) + T_a$

WHERE

T_j = Junction Temperature
 P_d = Total Power Dissipation
 $R_{\theta jc}$ = Junction to Case Thermal Resistance
 $R_{\theta cs}$ = Case to Heat Sink Thermal Resistance
 $R_{\theta sa}$ = Heat Sink to Ambient Thermal Resistance
 T_c = Case Temperature
 T_a = Ambient Temperature
 T_s = Heat Sink Temperature

EXAMPLE:

This example demonstrates an analysis where the regulator is at one-half of its maximum rated power dissipation, which occurs when the output current is at 1.5 amps.

Conditions for MSK 5330-5:

$V_{in} = -7.0V$; $I_{out} = -1.5A$

- 1.) Assume 45° heat spreading model.
- 2.) Find regulator power dissipation:

$$\begin{aligned} P_d &= (V_{in} - V_{out})(I_{out}) \\ P_d &= (-7 - (-5))(-1.5) \\ &= 3.0W \end{aligned}$$

- 3.) For conservative design, set $T_j = +125^\circ C$ Max.
- 4.) For this example, worst case $T_a = +90^\circ C$.
- 5.) $R_{\theta jc} = 4.6^\circ C/W$ from the Electrical Specification Table.
- 6.) $R_{\theta cs} = 0.15^\circ C/W$ for most thermal greases.
- 7.) Rearrange governing equation to solve for $R_{\theta sa}$:

$$\begin{aligned} R_{\theta sa} &= ((T_j - T_a)/P_d) - (R_{\theta jc}) - (R_{\theta cs}) \\ &= (125^\circ C - 90^\circ C)/3.0W - 4.6^\circ C/W - 0.15^\circ C/W \\ &= 6.9^\circ C/W \end{aligned}$$

In this case the result is 6.9°C/W. Therefore, a heat sink with a thermal resistance of no more than 6.9°C/W must be used in this application to maintain the regulator junction temperature under 125°C.

TYPICAL PERFORMANCE CURVES

GROUND PIN CURRENT

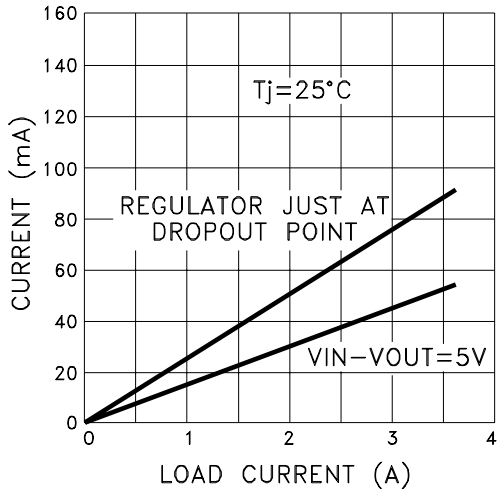

DROPOUT VOLTAGE vs. OUTPUT CURRENT

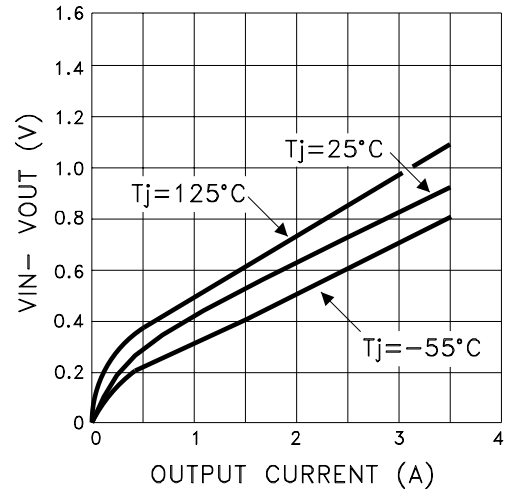

INTERNAL CURRENT LIMIT vs. $V_{IN} - V_{OUT}$

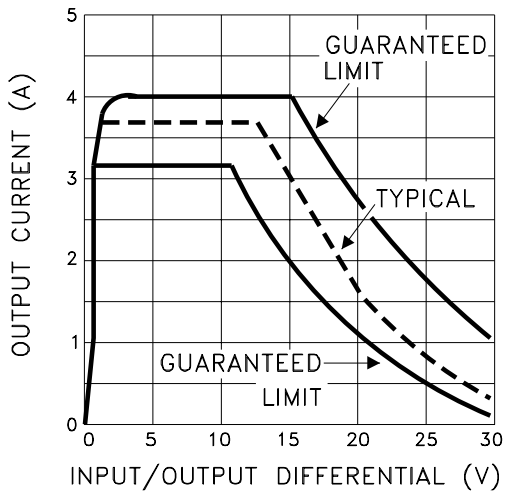

RIPPLE REJECTION vs. FREQUENCY

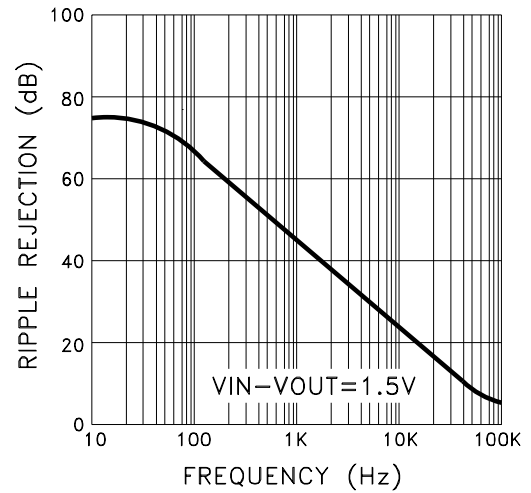

LOAD TRANSIENT RESPONSE

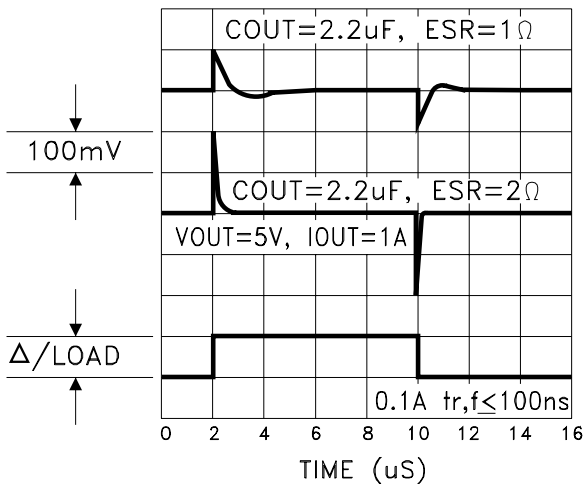

POWER DISSIPATION vs. TEMPERATURE

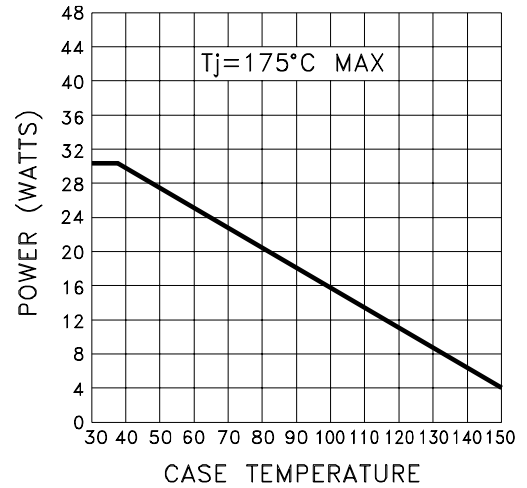

MECHANICAL SPECIFICATIONS

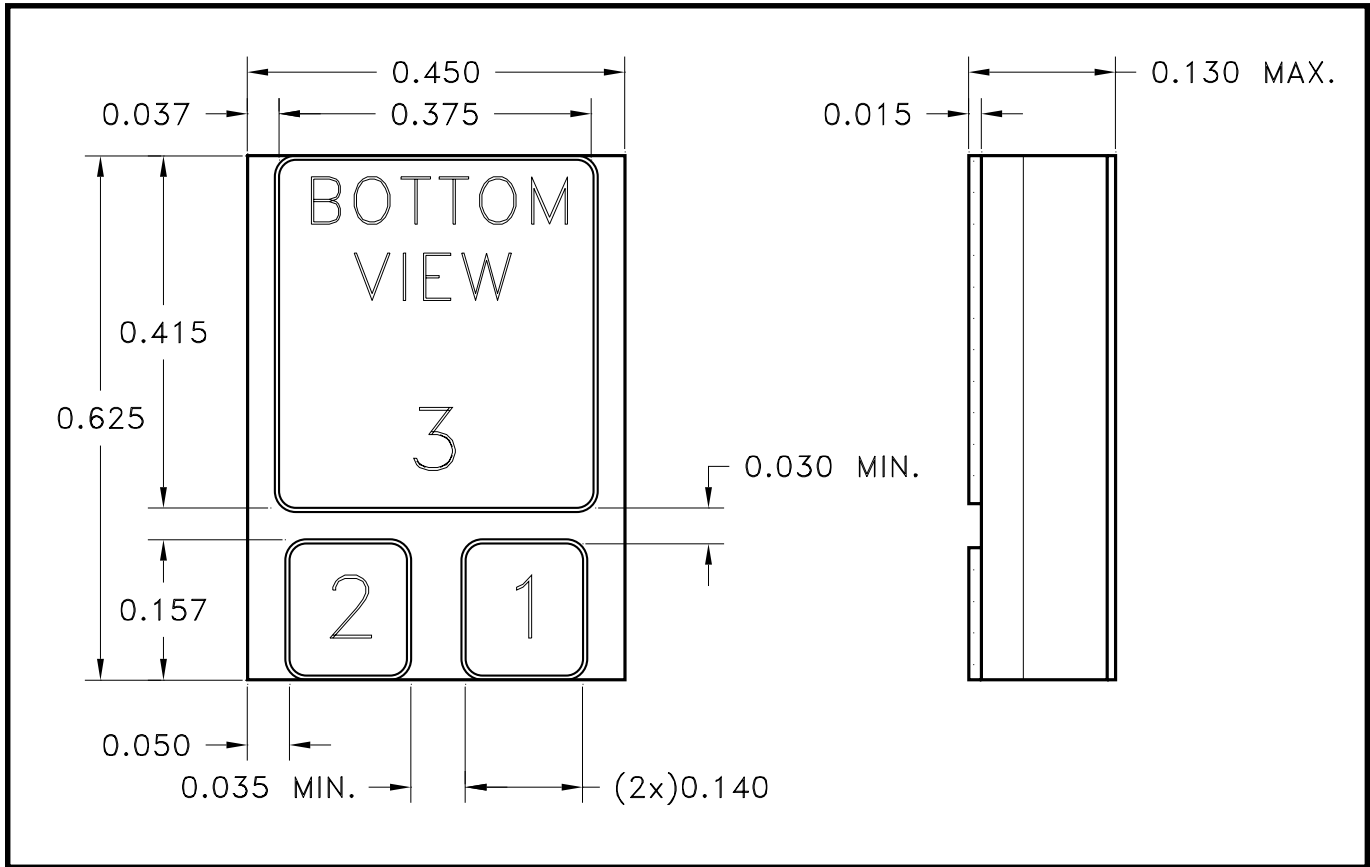

NOTE: ALL DIMENSIONS ARE ± 0.010 INCHES UNLESS OTHERWISE LABELED.

ORDERING INFORMATION

MSK5330-5.0 H

SCREENING

BLANK = INDUSTRIAL; E = EXTENDED RELIABILITY;
H = MIL-PRF-38534, CLASS H

OUTPUT VOLTAGE

5.0 = -5.0V, 5.2 = -5.2V, 10 = -10.0V, 12 = -12.0V, 15 = -15.0V

GENERAL PART NUMBER

The above example is a -5.0V, Military regulator.

M.S. Kennedy Corp.
4707 Dey Road, Liverpool, New York 13088
Phone (315) 701-6751
FAX (315) 701-6752
www.mskennedy.com

The information contained herein is believed to be accurate at the time of printing. MSK reserves the right to make changes to its products or specifications without notice, however, and assumes no liability for the use of its products. Please visit our website for the most recent revision of this datasheet.