

MSK5805RH Evaluation Board User's Guide

By Bryan Horton & Paul Musil, MS Kennedy Corp.; Revised 12/23/13

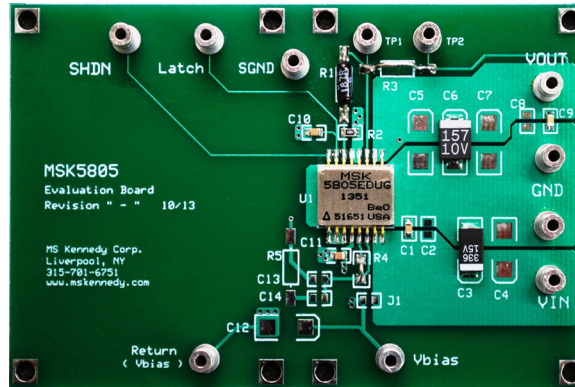

Introduction

The MSK5805RH is the latest addition to MSK58XXRH series of RAD HARD Ultra Low Drop Linear Regulators. Building on this heritage, the MSK5805RH is designed specifically for lower current applications. Application is simplified by lower quiescent current, lower startup currents, lower output capacitance requirements, adjustable output, and a smaller footprint. Flexibility is also enhanced by the introduction of the single resistor adjustable current limit, and optional frequency response compensation schemes. The logic level compatible shutdown pin is ideal for power supply sequencing and fault recovery. Transient over load tolerance and optional latching fault protection is set by a single capacitor, ensuring robust yet simple designs. The MSK5805RH is packaged in a hermetically sealed 16 pin flatpack and is available with a straight or gull wing lead form.

The evaluation board provides a platform from which to evaluate new designs with ample real estate to make changes and evaluate results. Evaluation early in the design phase reduces the potential for problems at the application PCB level.

This application note is intended to be used in conjunction with the MSK5805RH data sheet and the RH1573 data sheet. Reference those documents for additional application information and specifications.

Setup

Use the standard turret terminals to connect to your power supply and test equipment. Connect a power supply across the VIN and GND terminals. Connect a power supply across the Vbias and Return terminals (see note 1). The evaluation board can be configured to run off of a single >2.9V supply by installing jumper J1. Connect the load between the VOUT and GND terminals. Use separate or Kelvin connections to connect input and output monitoring equipment, referencing to the low current SGND plane is ideal.

Note 1: If V_{in} and V_{bias} are applied simultaneously, i.e. J1 installed, the Output voltage should rise to $> V_{OUT} + 1V$ before the expiration of the latch timeout period. Optionally the LATCH pin can be pulsed low, or the Shutdown pin can be toggled to restart the device.

Output Voltage Programming And Remote Sensing.

Unlike many other regulators, the MSK5805RH is capable of remotely sensing the load voltage and self correcting for drops due to trace resistance between regulator output and the load. For applications that merit the tightest possible regulation, simply bring a short Kelvin sense traces out from the load to the top of the feedback divider and V_{OUT} SENSE pin. GDN1 pins, GND2 pins and load grounds should be connected close together. The usual layout guidelines apply to the high impedance FB pin node, minimize trace length and locate away from noisy areas. The evaluation card layout artwork is provided on page 6 for reference.

The output voltage can be programmed according to the following equations.

$$V_{OUT} = V_{FB} * (1+R1/R2) \quad \rightarrow \quad R1 = R2 * (V_{OUT}/V_{FB}-1)$$

Given: $V_{FB} = 1.265V$ Typ.

Factory Configuration: $R1 = 187\Omega$, $R2 = 1K\Omega$, $V_{OUT} = 1.5V$

Over Load Latch Timeout Programming

During over load conditions, a $7.2\mu A$ nominal current source charges the external LATCH pin capacitor. Once this capacitor charges to $1.6V$, the pass transistor latches off. The latch capacitor can be sized to tolerate momentary overloads of arbitrary duration, or shorted to ground to disable the latch off function. Reference the MSK5805 data sheet for more details. The regulator output can be recovered from a latched off state by cycling power, pulsing the latch pin low, or by toggling the SHUTDOWN pin.

Current Limit Programming

The MSK5805RH Evaluation Board is provided with a jumper wire installed in the location of R4. In this configuration, at $V_{IN} = 2.5V$ the MSK5805RH will enter current limit when load current exceeds approximately $1.5A$. The application current limit level is a function of both V_{IN} and R4. Increasing V_{IN} will increase the current limit threshold, while increasing R4 will decrease the current limit threshold.

A single resistor can be selected to provide well bounded fault protection for any application. Reference the datasheet curves to select values of R4 for any given application. R4 should be sized to handle the pass transistor's worst case base current plus the base emitter resistor current ($\approx 5mA$). The worst case power dissipation of R4 is approximated by the following equation:

$$P_{R4} = [(I_{OUTmax}/40) + 5mA]^2 \times R4$$

Low drop out regulators such as the MSK5805RH demand increased current during start up. This increased current consists of two components, increased pass transistor base current and the corresponding collector current required charge the output capacitor. Increasing R_{ADJ} can substantially reduce both components. Setting the current limit too close to the operating levels may result in excessive dropout voltage at the desired operating current.

Stability Assessment

Being able to verify the frequency response and stability margins of the regulator system is critical for most high reliability applications. Accurate measurement and analysis early in the design phase can help avoid costly late stage fixes. Analyzing load step response waveforms allow a quick check for gross stability issues, but cannot provide the information needed to validate a design or to take corrective measures. The waveform to the right demonstrates the typical

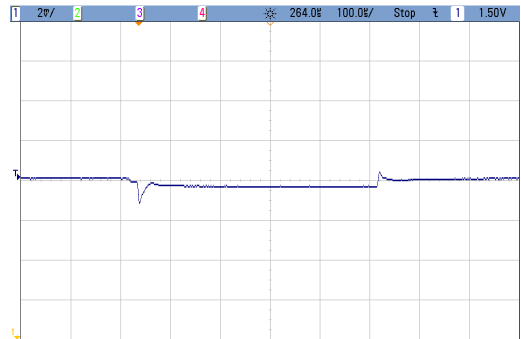

10mA to 1A load step response of the MSK5805RH evaluation board. Bode plots are a common and accessible graphical rendering of this information. However generating one is often difficult or impossible due to the invasive nature of the measurement technique.

The MSK5805RH simplifies in circuit stability assessment by breaking out the necessary measurement points and provides a convenient internal signal injection resistor. A network analyzer and a few simple steps are all that is needed to exercise this feature on the MSK5805RH evaluation board.

First, remove the jumper wire installed at R3. The internal injection resistor is sized to match the output impedance of most common lab signal generators and network analyzers. Installing a lower value resistor at R3 may be helpful in achieving appropriate input signal amplitudes. Connect the input signal source across TP1 and TP2, a wideband 1:1 signal transformer is required to provide galvanic isolation between the source and test circuit. TP1 is the input to the control loop, and TP2 is the output. Connect the network analyzer input probes accordingly. Use the SGND turret as the network analyzer probe ground reference. Power up the evaluation board, apply a load, and start the sweep. Electronic loads are not recommended for this test as they present an unspecified complex impedance to the regulator, potentially skewing the data

Applying the appropriate input signal amplitudes is critical for obtaining accurate data. There are no hard rules to follow in setting the proper amplitudes. But having a general understanding of what is being done will help in obtaining useful information. The information of interest is the small signal frequency response of the whole control loop, thus every stage of the loop must be operating in a linear region. Applying too large of an input signal will overdrive one or more stages. A common symptom of an overdriven stage is a sudden and drastic change in the slope of the gain and/or phase curves. Too small of an input signal can result in noisy or erratic data due to the noise floor limitations of the network analyzer. Use a small as possible signal that yield good data. Rule of thumb: if the

input signal can be increased or decreased by several dB without a significant change in slope of the gain or phase curves, then the signal amplitude is at an appropriate level. The amplitude levels may also need to be adjusted for some frequency bands.

Input/Output Capacitors

The specific value of the input capacitors C1, C3, C11, and C12 are not critical but should be selected to provide a sufficiently low impedance source within the bandwidth of the regulator to avoid stability and dropout issues. The MSK5805 evaluation board is provided with a factory installed 33 μ F capacitor and is a good starting point for most applications.

The load impedance, including the output capacitors, to the MSK5805RH determines the dominant pole in the control loop. The factory installed bulk output capacitor C6 is a AVX TAZ series 150 μ F tantalum capacitor; see BOM for specific part numbers. AVX TAZ series capacitors were chosen to provide a design starting point using high reliability MIL-PFR-55365/4 qualified capacitors. This capacitor was selected to provide good stability margins for the broadest possible range of applications and conditions. Many applications are constrained to much narrower operating conditions, and this capacitor value can usually be reduced. A 47 μ F AVX TAZ series tantalum capacitor is furnished with the evaluation board as a good alternative for lower load current applications, (\leq 250mA). Paralleling two 47 μ F capacitors further improves stability margins. Other capacitor values may work well for a given application, but analysis and measurement of the regulator system stability is recommended. Ceramic capacitor C9 is provided for basic high frequency decoupling at the load. Large values of ceramic capacitance ($>$ 1 μ F) close to the regulator may begin to influence the loop response.

Compensation

Additional measures can be implemented to optimize the frequency response of the MSK5805RH while further reducing the bulk output capacitance. A simple C, RC, or CRC network tied from the IADJ2 pin to either the output or ground can be used to establish additional break points in the regulator's frequency response. The MSK5805RH Evaluation board provides component pads R5, C13, and C14 for prototyping and testing of these schemes. The figures below demonstrate one configuration that relies on this external compensation. Careful analysis and verification testing is required to ensure acceptable performance across the range of operating conditions and aging effects.



500mA Load Step Waveform

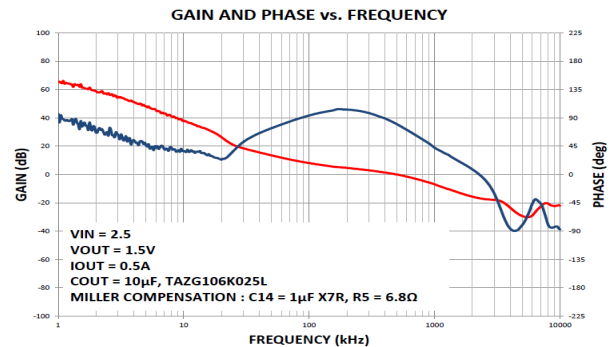

Gain Margin = 16.8dB Phase Margin = 80°

Typical Performance

Parameter	Conditions	Units	Typical
Output Voltage	$V_{bias} = 5.0V, V_{in} = 2.5V, I_{OUT} = 0.5A$	V	1.5
Line Regulation	$I_{OUT} = 0.01A, 2.9V \leq V_{in}, V_{bias} \leq 7.5V$	%	0.01
Load Regulation	$V_{bias} = 5.0V, V_{in} = 2.5V,$ $2.9V \leq I_{OUT} \leq 7.5V,$	%	-0.02
Dropout Voltage	$V_{bias} = 5.0V, I_{OUT} = 0.5A$	mV	160
Current Limit	$V_{bias} = 5.0V, V_{in} = 2.5V$	A	1.5
Gain Margin	$V_{bias} = 5.0V, V_{in} = 2.5V, I_{OUT} = 0.25A$	dB	14.5
Phase Margin	$V_{bias} = 5.0V, V_{in} = 2.5V, I_{OUT} = 0.25A$	°	72

MSK5805RH Evaluation Board Schematic

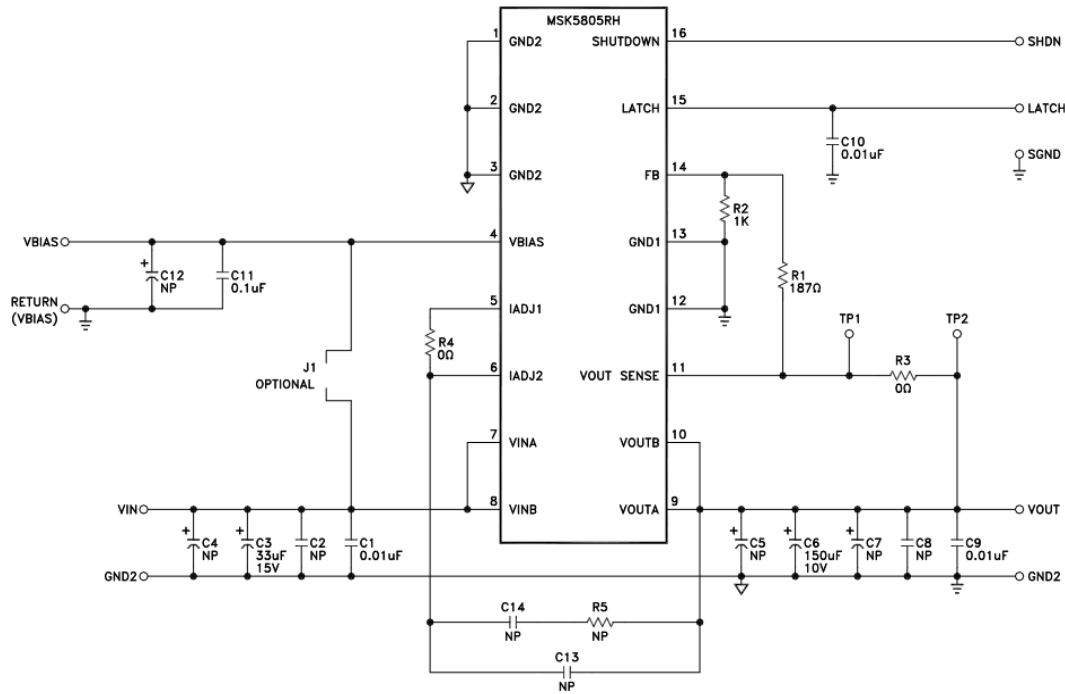

NOTES:

1. "NP" - NOT POPULATED COMPONENTS ARE NOT POPULATED SPACES PROVIDED FOR EVALUATION OF DIFFERENT ELECTRICAL CONFIGURATIONS.
2. SEE BOM FOR SPECIFIC COMPONENT INFORMATION.
3. C6= TAZX157K010L
4. C3= TAZH336K015C

PCB Artwork

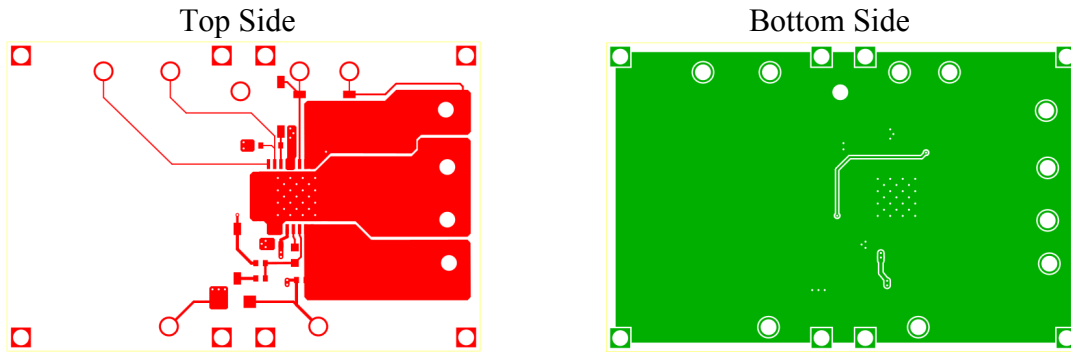

Bill Of Materials

Ref Des	Description	Manufacturer	Part Number
U1	ULDO Linear Regualtor	MS Kennedy Corp	MSK5805EDUG
C1, 9, 10	0.01 μ F, 10%, 50V, 8050, X7R Capacitor	AVX	08055C103KAT2A
C11	0.1 μ F, 10%, 100V, 8050, X7R Capacitor	KEMET	C0805C104K1RACTU
C3	33 μ F, 10%, 15V, Tantalum Capacitor	AVX	TAZH336K015C
C6	150 μ F, 10%, 10V, Tantalum Capacitor	AVX	TAZX157K010L
C6 (alternate)	47 μ F, 10%, 10V, Tantalum Capacitor	AVX	TAZH476K010L
C2,4,5,7,8,12 -14	Not Populated		
R1	187 Ω , 1%, 1/8W, Axial leaded Resistor	Vishay/DALE	RNC55H1870FSR36
R2	1k Ω , 1%, 1/8W, 8050 SMD Resistor	Panasonic	ERJ-6ENF1001V
R3	Not Populated		
R4	Short Jumper		