



**RAD HARD ULTRA LOW
DROPOUT ADJUSTABLE
POSITIVE LINEAR REGULATOR**

5821RH

FEATURES:



- Manufactured using **LINEAR TECHNOLOGY** Space Qualified RH1573 Die
- New "Harder" Version of MSK5921RH
- Total Dose Hardened to 300 Krads(Si) (Method 1019.7 Condition A)
- Ultra Low Dropout for Reduced Power Consumption
- External Shutdown
- Latching Overload Protection
- Adjustable Output Using Two External Resistors
- Output Current Limit
- Available in 4 Lead Form Options: Straight, Up, Down and Gull Wing
- Available to DLA SMD 5962F09216
- ELDRS Tested to 100 Krads(Si) (Method 1019.7 Condition D)
- Neutron Tested to 1.0×10^{12} n/cm² (Method 1017.2)

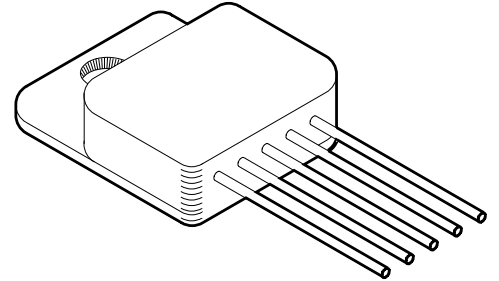

DESCRIPTION:

The MSK5821RH is a radiation hardened adjustable linear regulator typically capable of delivering 5.0 amps of output current. The typical dropout is only 0.22 volts with a 2.5A load. An external shutdown function is ideal for power supply sequencing. This device also has latching overload protection that requires no external current sense resistor. The MSK5821RH is radiation hardened and specifically designed for space/satellite applications. The device is packaged in a hermetically sealed space efficient 5 pin SIP that is electrically isolated from the internal circuitry allowing for direct heat sinking.

EQUIVALENT SCHEMATIC

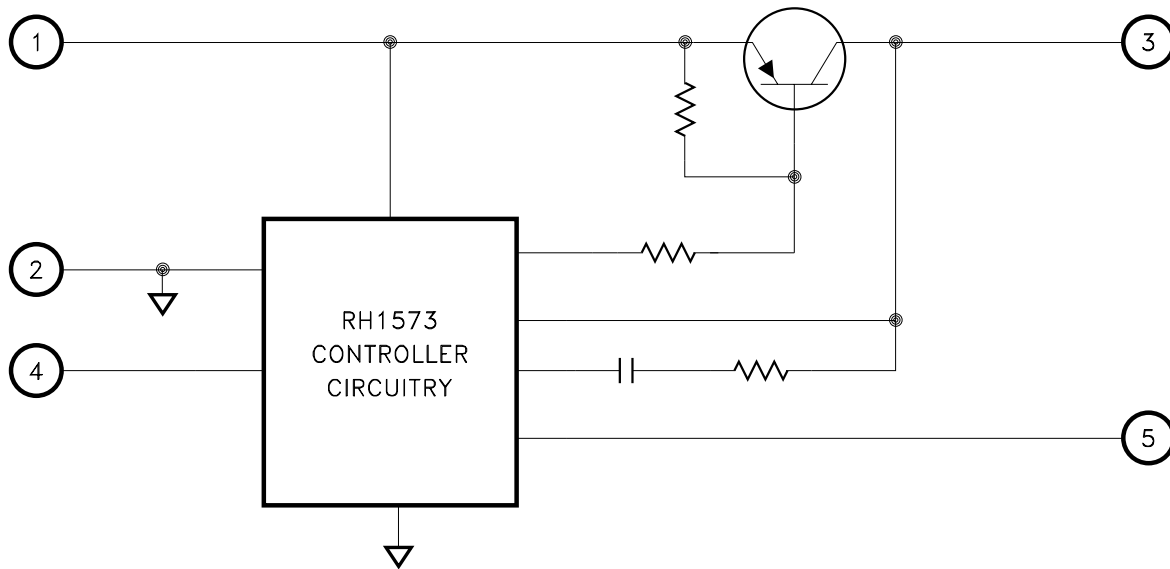

TYPICAL APPLICATIONS

- Satellite System Power Supplies
- Switching Power Supply Post Regulators
- Constant Voltage/Current Regulators
- Microprocessor Power Supplies

PIN-OUT INFORMATION

- 1 VIN
- 2 GND
- 3 VOUT
- 4 SHUTDOWN
- 5 ADJUST

CASE = ISOLATED

and the Linear Technology logo are registered trademarks and RH1573 is a copyright of Linear Technology Corporation

ABSOLUTE MAXIMUM RATINGS ^⑧

+VIN	Supply Voltage	+10V
VSD	Shutdown Voltage	10V
IOUT	Output Current	5A
Tc	Case Operating Temperature Range	
	MSK5821K/H RH	-55°C to +125°C
	MSK5821RH	-40°C to +85°C

T _{ST}	Storage Temperature Range	-65°C to +150°C
T _{LD}	Lead Temperature Range	
	(10 Seconds)	300°C
P _D	Power Dissipation	See SOA Curve
T _J	Junction Temperature	150°C

ELECTRICAL SPECIFICATIONS

Parameter	Test Conditions ^① ^⑪	Group A Subgroup	MSK5821K/H			MSK5821			Units		
			Min.	Typ.	Max.	Min.	Typ.	Max.			
Input Voltage Range ^② ^⑧	10mA ≤ I _{OUT} ≤ 1.0A	1	2.9	-	6.5	2.9	-	6.5	V		
		2,3	2.9	-	6.5	-	-	-	V		
Feedback Voltage	I _{OUT} = 1A R ₁ = 187Ω	1	1.225	1.265	1.305	1.202	1.265	1.328	V		
		2,3	1.225	-	1.305	-	-	-	V		
			Post 100KRAD(Si)	1	1.225	-	1.305	1.202	-	1.328	V
			Post 300KRAD(Si)	1	1.225	-	1.310	1.202	-	1.328	V
Feedback Pin Current ^②	V _{FB} = 1.265V 10mA ≤ I _{OUT} ≤ 3.0A	1,2,3	0	-	5.0	0	-	5.0	μA		
Quiescent Current	VIN = 6.5V Not Including I _{OUT}	1	-	14	20	-	14	20	mA		
		2,3	-	14	20	-	-	-	mA		
Line Regulation ^⑨	I _{OUT} = 50mA V _{OUT} +0.4V ≤ VIN ≤ V _{OUT} +1.3V	1	-	±0.01	±0.50	-	0.01	±0.60	%V _{OUT}		
		2,3	-	-	±2.5	-	-	-	%V _{OUT}		
Load Regulation ^⑨	50mA ≤ I _{OUT} ≤ 3.0A	1	-	±0.06	±0.80	-	0.06	±1.0	%V _{OUT}		
		2,3	-	-	±2.5	-	-	-	%V _{OUT}		
Dropout Voltage ^⑩	Delta FB = 1% I _{OUT} = 2.5A	1	-	0.22	0.40	-	0.22	0.45	V		
		2,3	-	0.26	0.40	-	-	-	V		
Minimum Output Current ^②	2.9V ≤ VIN ≤ 6.5V R ₁ = 187Ω	1	-	8	10	-	8	10	mA		
		2,3	-	9	10	-	-	-	mA		
Output Voltage Range ^②	VIN = 6.5V	-	1.5	-	6.0	1.5	-	6.0	V		
Output Current Limit ^⑦	VIN = 3.5V V _{OUT} = 2.5V	1	3.0	4.0	5.0	3.0	4.0	5.0	A		
		2,3	3.0	4.0	5.0	-	-	-	A		
Shutdown Threshold	V _{OUT} ≤ 0.2V (OFF) V _{OUT} = Nominal (ON)	1	1.0	1.3	1.6	1.0	1.3	1.6	V		
		2,3	1.0	1.3	1.6	-	-	-	V		
Ripple Rejection ^②	F = 120Hz I _{OUT} = 50mA	4	65	-	-	65	-	-	dB		
		5,6	65	-	-	-	-	-	dB		
Phase Margin ^②		4	30	-	-	30	-	-	degrees		
Gain Margin ^②		4	10	18	-	10	18	-	dB		
Equivalent Noise Voltage ^②	Referred to Feedback Pin	4	-	-	50	-	-	50	μVRMS		
Thermal Resistance ^②	Junction to Case @ 125°C Output Device	-	-	2.5	2.9	-	2.5	2.9	°C/W		

NOTES:

- ① Unless otherwise specified, VIN = 5.0V, R₁ = 1.62K, V_{SHUTDOWN} = 0V and I_{OUT} = 10mA. See Figure 2, typical application circuit.
- ② Guaranteed by design but not tested. Typical parameters are representative of actual device performance but are for reference only.
- ③ Industrial grade devices shall be tested to subgroups 1 and 4 unless otherwise requested.
- ④ Military grade devices ("H" suffix) shall be 100% tested to subgroups 1, 2, 3 and 4.
- ⑤ Subgroup 5 and 6 testing available upon request.
- ⑥ Subgroup 1, 4 TC = +25°C
Subgroup 2, 5 TC = +125°C
Subgroup 3, 6 TA = -55°C
- ⑦ Output current limit is dependent upon the values of VIN and V_{OUT}. See Figure 1 and typical performance curves.
- ⑧ Continuous operation at or above absolute maximum ratings may adversely effect the device performance and/or life cycle.
- ⑨ VIN shall be as specified or VIN Min, whichever is greater.
- ⑩ Not applicable when V_{OUT} < VIN Min - dropout voltage maximum.
- ⑪ Pre and post irradiation limits, up to 300Krad TID, are identical unless otherwise specified.
- ⑫ Reference DLA SMD 5962F09216 for electrical specification for devices purchased as such.
- ⑬ Internal solder reflow temperature is 180°C, do not exceed.

APPLICATION NOTES

PIN FUNCTIONS

VIN - This pin provides power to all internal circuitry including bias, start-up, thermal limit and overcurrent latch. Input voltage range is 2.9V to 6.5V.

GND - Internally connected to ground, this pin should be connected externally by the user to the circuit ground.

SHUTDOWN - There are two functions to the SHUTDOWN pin. It may be used to disable the output voltage or to reset a current latch condition. To activate the shutdown/reset functions the user must apply a voltage greater than 1.6V to the SHUTDOWN pin. The voltage applied to the SHUTDOWN pin can be greater than the input voltage. The output voltage will turn on when the SHUTDOWN pin is pulled below the threshold voltage. If the SHUTDOWN pin is not used, it should be connected to ground. It should be noted that with the shutdown pin tied to ground, a current latch condition can only be reset by cycling power off, then on.

VOOUT - This is the output pin for the device.

ADJUST - The ADJUST pin is the inverting input of the internal error amplifier. The non-inverting input is connected to an internal 1.265V reference. This error amplifier controls the drive to the output transistor to force the ADJUST pin to 1.265V. An external resistor divider is connected to the output, ADJUST pin and ground to set the output voltage.

OVERCURRENT LATCH

Overcurrent protection is provided by the MSK5821RH series through the use of a timed latch off circuit. The internal latch timeout is triggered by an overcurrent condition. To allow for start up surge currents, the timeout is approximately 5.5mS at 25°C. If the overcurrent condition remains at the end of the timeout cycle, the regulator will latch off until the latch is reset. Reset the latch by pulling the shutdown pin high or cycling VIN off then back on. A thermal limit condition will trigger the latch with no time out delay.

INPUT POWER SUPPLY BYPASSING

To maximize transient response and minimize power supply transients it is recommended that two 47µF tantalum capacitors are connected between VIN and ground. A 0.1µF ceramic capacitor should also be used for high frequency bypassing. See typical application circuit.

OUTPUT CAPACITOR SELECTION

Low ESR output capacitors are required to maintain regulation and stability. Four CWR29FB227 (PN TAZH227K010L) tantalum capacitors in parallel with ceramic decoupling capacitors (0.1µF typical) provides sufficient gain and phase margin for most applications. The maximum ESR specification for the CWR29FB227 capacitor is 180mΩ at 100kHz and is sufficient for many applications. It has been found through full WCCA that screening for a maximum ESR of 57mΩ ensures EOL stability criteria to be met for many applications with the most stringent requirements. The typical ESR of the TAZH227K010L is 49mΩ. Analysis of the final design is recommended to ensure stability requirements are met.

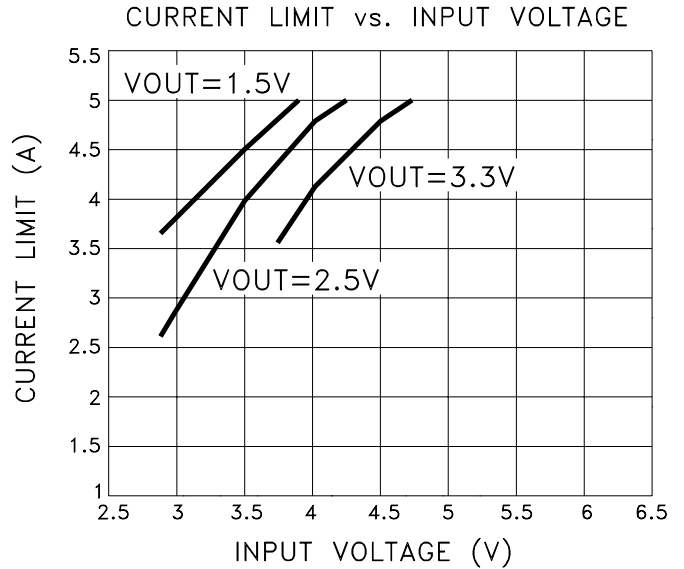

FIGURE 1

CURRENT LIMIT AND SOA

The MSK5821RH current limit function is directly affected by the input and output voltages. Figure 1 illustrates the relationship between VIN and ICL for various output voltages. It is very important for the user to consult the SOA curve when using input voltages which result in current limit conditions beyond 4.5 Amps. When using input voltages which result in current limit above 4.5 Amps, the user must maintain output current within the SOA curve to avoid damage to the device. Note that 5 Amp maximum is due to current carrying capability of the internal wirebonds.

THERMAL LIMITING

The MSK5821RH control circuitry has a thermal shutdown temperature of approximately 150°C. This thermal shutdown can be used as a protection feature, but for continuous operation, the junction temperature of the pass transistor must be maintained below 150°C. Proper heat sink selection is essential to maintain these conditions. Exceeding the thermal limit activates the latch feature of the MSK5821RH. Toggle the shutdown pin high then low or cycle power to reset the latch. See SHUTDOWN pin description and overcurrent latch description for more information.

APPLICATION NOTES CONT'D

HEAT SINK SELECTION

To select a heat sink for the MSK5821RH, the following formula for convective heat flow may be used.

Governing Equation:

$$T_J = P_D \times (R_{\theta JC} + R_{\theta CS} + R_{\theta SA}) + T_A$$

Where

T_J	=	Junction Temperature
P_D	=	Total Power Dissipation
$R_{\theta JC}$	=	Junction to Case Thermal Resistance
$R_{\theta CS}$	=	Case to Heat Sink Thermal Resistance
$R_{\theta SA}$	=	Heat Sink to Ambient Thermal Resistance
T_A	=	Ambient Temperature

$$\text{Power Dissipation} = (V_{IN} - V_{OUT}) \times I_{OUT}$$

Next, the user must select a maximum junction temperature. The absolute maximum allowable junction temperature is 150°C. The equation may now be rearranged to solve for the required heat sink to ambient thermal resistance ($R_{\theta SA}$).

Example:

An MSK5821RH is connected for $V_{IN} = +3.3V$ and $V_{OUT} = +2.5V$. I_{OUT} is a continuous 3A DC level. The ambient temperature is +25°C. The maximum desired junction temperature is +125°C.

$R_{\theta JC} = 4.0^\circ C/W$ and $R_{\theta CS} = 0.15^\circ C/W$ for most thermal grease
 Power Dissipation = $(3.3V - 2.5V) \times (3A)$
 = 2.4 Watts

Solve for $R_{\theta SA}$:

$$R_{\theta SA} = \left[\frac{125^\circ C - 25^\circ C}{2.4W} \right] - 2.9^\circ C/W - 0.15^\circ C/W$$

$$= 38.6^\circ C/W$$

In this example, a heat sink with a thermal resistance of no more than 38.6°C/W must be used to maintain a junction temperature of no more than 125°C.

TYPICAL APPLICATIONS CIRCUIT

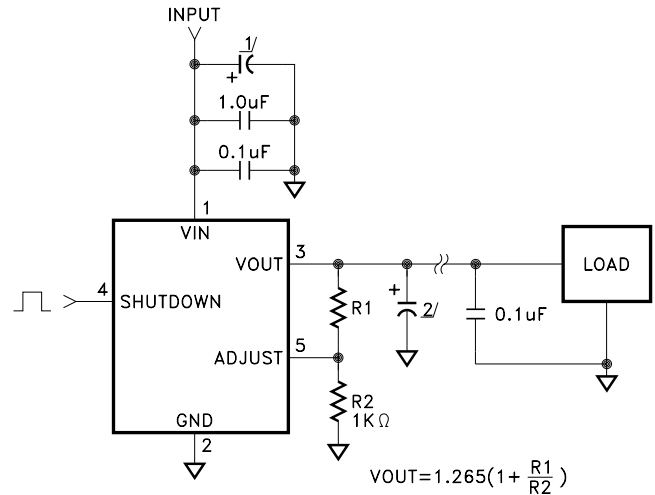

1/ 2 PIECES PART NUMBER
 TAZH476K020C (CWR19JC476K)

2/ 4 PIECES PART NUMBER
 TAZH227K010L (CWR29FB227)

FIGURE 2

OUTPUT VOLTAGE SELECTION

As noted in the above typical applications circuit, the formula for output voltage selection is

$$V_{OUT} = 1.265 \left[1 + \frac{R_1}{R_2} \right]$$

A good starting point for this output voltage selection is to set $R_2 = 1K$. By rearranging the formula it is simple to calculate the final R_1 value.

$$R_1 = R_2 \left[\frac{V_{OUT}}{1.265} - 1 \right]$$

START UP CURRENT

The MSK5821RH sinks increased current during startup to bring up the output voltage. Reference the "Saturated Drive Current vs. Input Voltage" graph in the typical performance curves of this data sheet and the "Understanding Startup Surge Current With RH1573 Based Rad Hard LDO Regulators" application note in the application notes section of the TTM Technologies Web site for more information.

TOTAL DOSE RADIATION TEST PERFORMANCE

Radiation performance curves for TID testing have been generated for all radiation testing performed by TTM Technologies. These curves show performance trends throughout the TID test process and can be located in the MSK5810RH radiation test report. The complete radiation test report is available in the RAD HARD PRODUCTS section on the TTM Technologies website.

Reference the MSK5826RH RAD REPORT for ELDRS and Neutron results.

TYPICAL PERFORMANCE CURVES

SHUTDOWN VOLTAGE THRESHOLD vs. TEMPERATURE

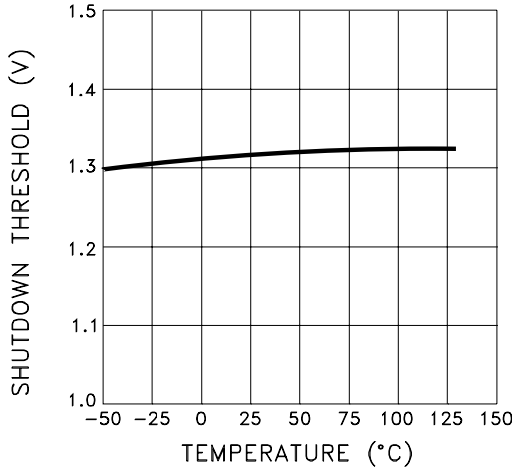

SHUTDOWN PIN CURRENT vs. SHUTDOWN PIN VOLTAGE

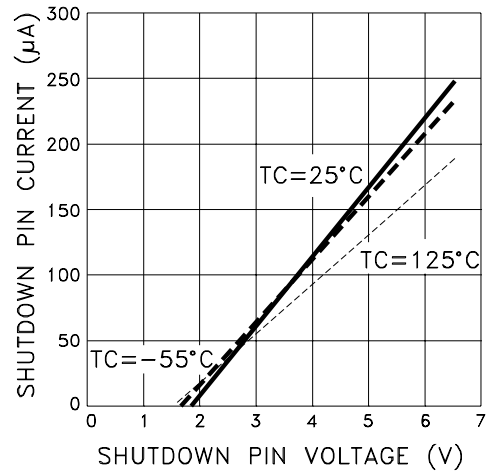

SOA OUTPUT CURRENT vs. VOLTAGE DROP

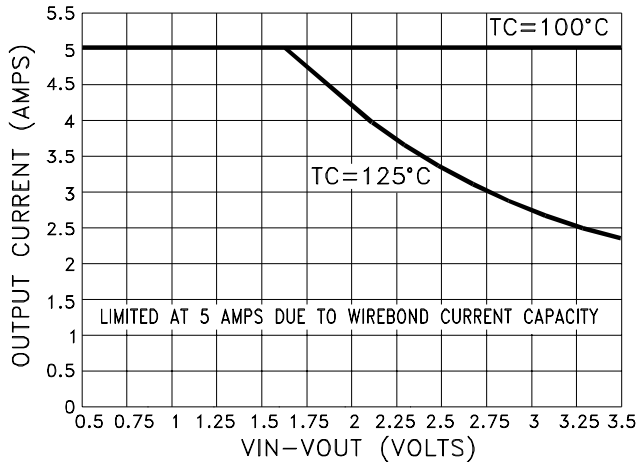

SATURATED DRIVE CURRENT vs. INPUT VOLTAGE

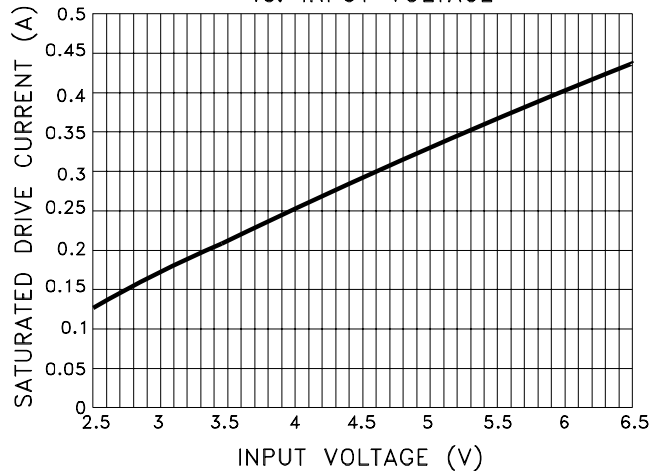

FEEDBACK PIN VOLTAGE vs. TEMPERATURE

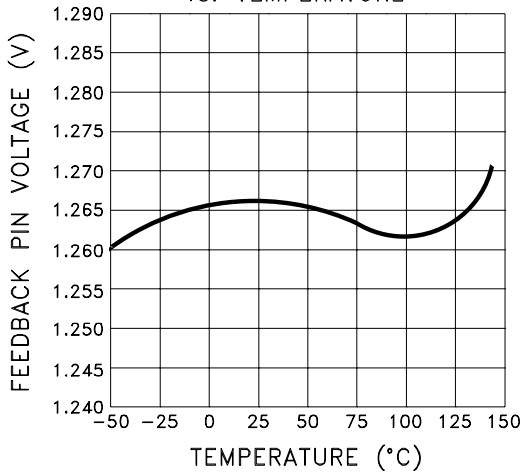

FEEDBACK PIN BIAS CURRENT vs. TEMPERATURE

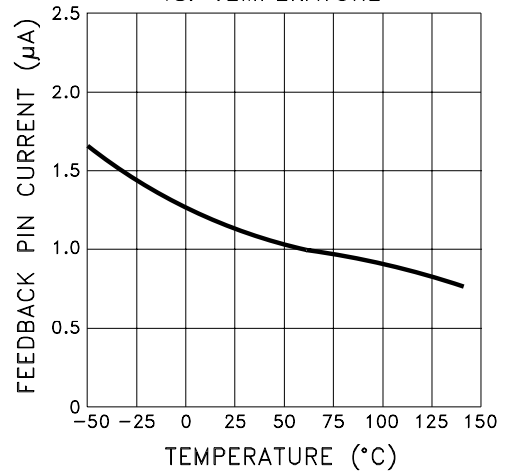

TYPICAL PERFORMANCE CURVES CONT'D

GAIN AND PHASE RESPONSE

The gain and phase response curves are for the typical application circuit at 25°C and are representative of typical device performance, but are for reference only. The performance should be analyzed for each application to insure individual program requirements are met. External factors such as temperature, input and output voltages, capacitors, etc. all can be major contributors. Please consult factory for additional details.

MSK5821RH GAIN AND PHASE vs. FREQUENCY

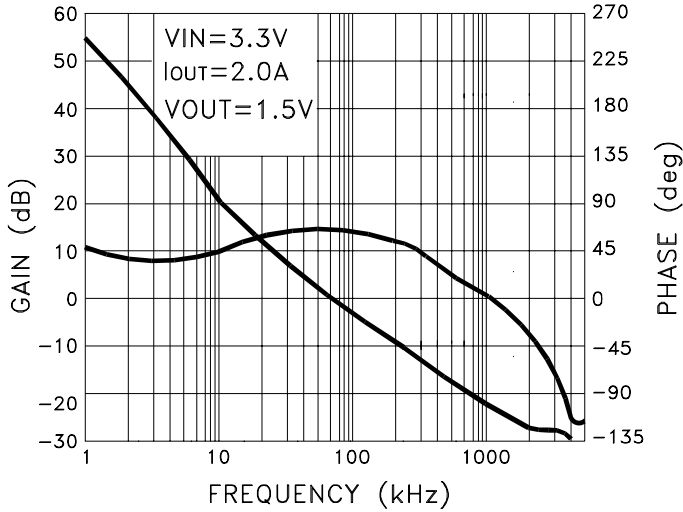

MSK5821RH GAIN AND PHASE vs. FREQUENCY

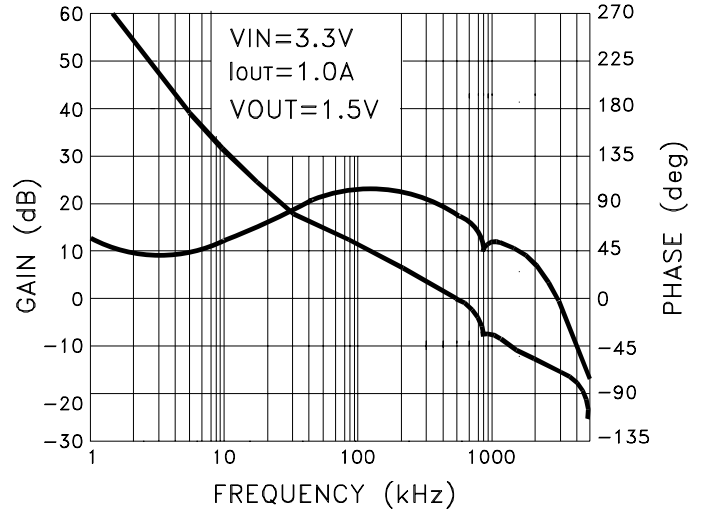

MSK5821RH GAIN AND PHASE vs. FREQUENCY

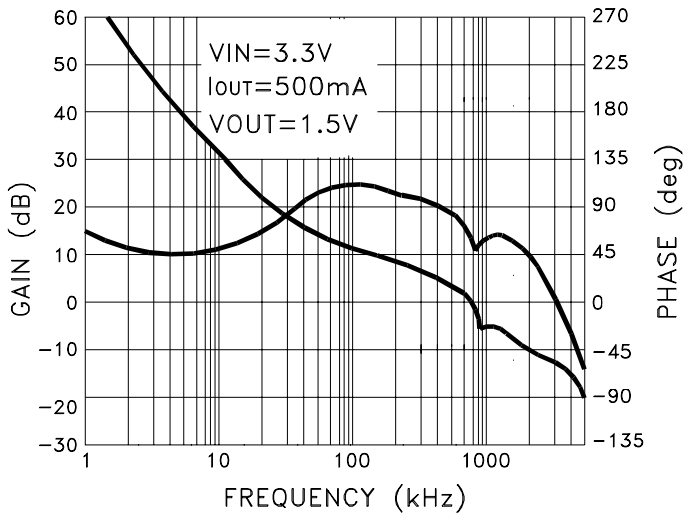

MSK5821RH GAIN AND PHASE vs. FREQUENCY

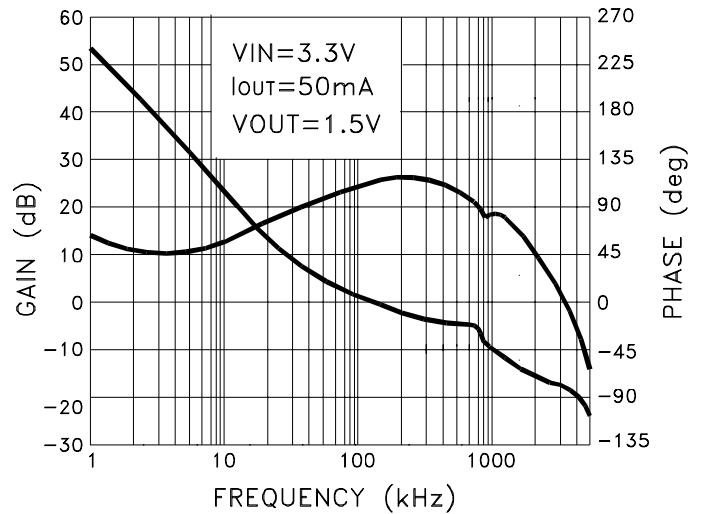

MECHANICAL SPECIFICATIONS

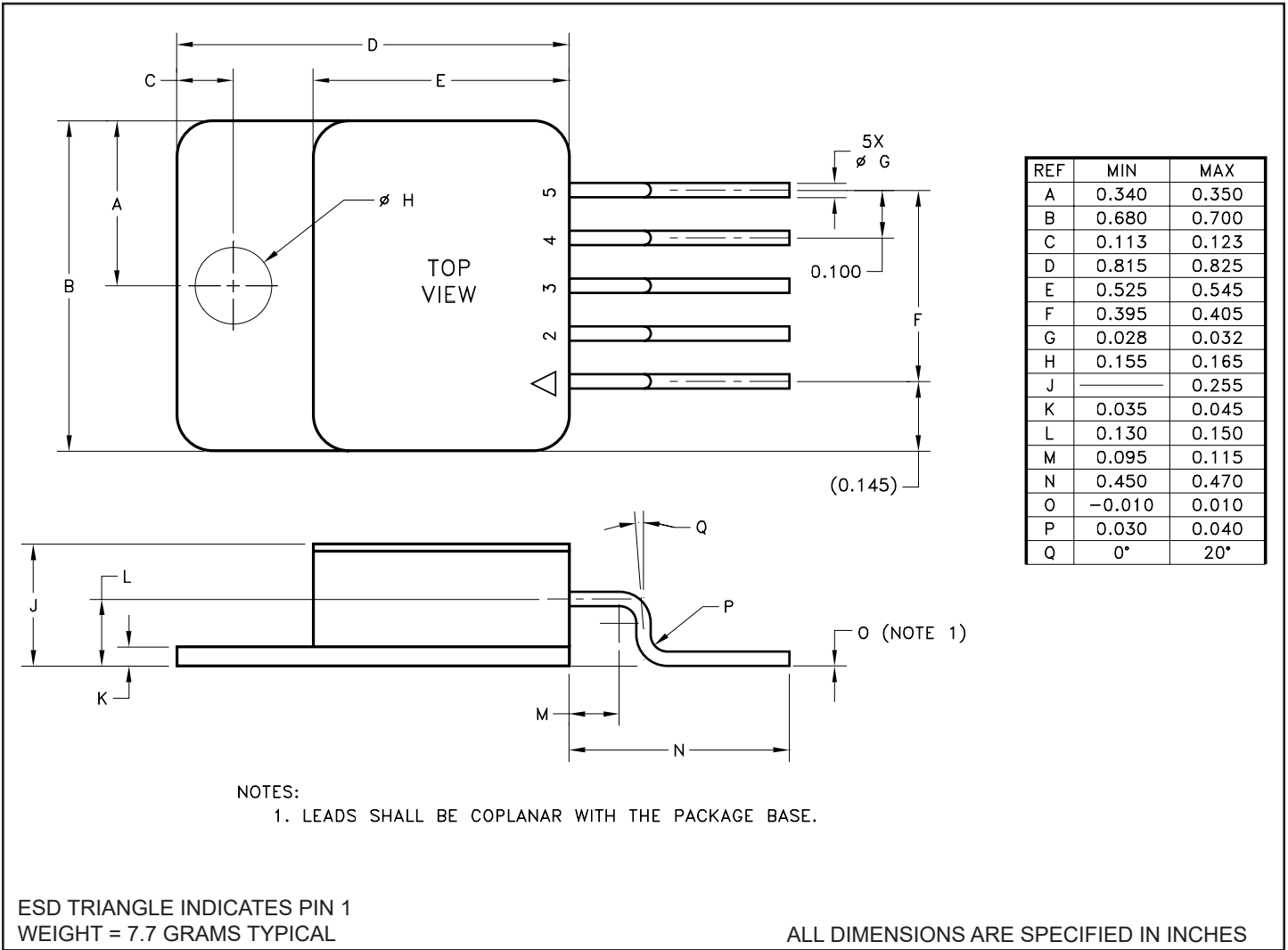

ORDERING INFORMATION

MSK5821 K RH GW

LEAD CONFIGURATIONS
GW = GULL WING

RADIATION HARDENED SCREENING
BLANK = INDUSTRIAL; H = MIL-PRF-38534 CLASS H;
K = MIL-PRF-38534 CLASS K

GENERAL PART NUMBER

The above example is an adjustable Class K regulator with gull wing leads.

NOTE: See DLA SMD 5962F09216 for DLA part number options.

MECHANICAL SPECIFICATIONS

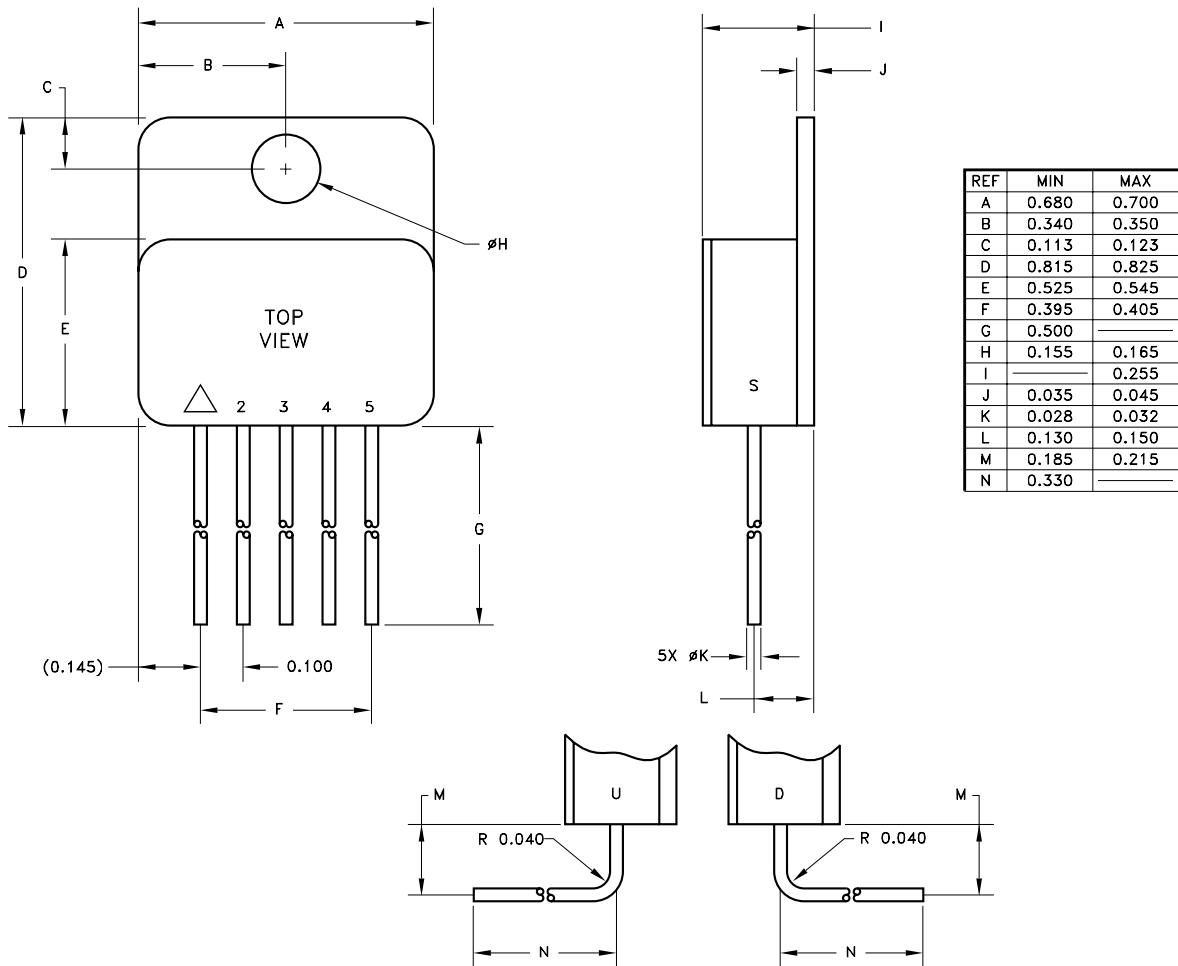

ESD TRIANGLE INDICATES PIN 1
WEIGHT = 7.7 GRAMS TYPICAL

ALL DIMENSIONS ARE SPECIFIED IN INCHES

ORDERING INFORMATION

MSK5821 K RH U

LEAD CONFIGURATIONS
S = STRAIGHT; U = BENT UP; D = BENT DOWN

RADIATION HARDENED SCREENING
BLANK = INDUSTRIAL; H = MIL-PRF-38534 CLASS H;
K = MIL-PRF-38534 CLASS K

GENERAL PART NUMBER

The above example is an adjustable Class K regulator with leads bent up.
NOTE: See DLA SMD 5962F09216 for DLA part number options.

REVISION HISTORY

REV	STATUS	DATE	DESCRIPTION
I	Released	06/14	Add shutdown pin to absolute maximum ratings and comment in shutdown pin description, new note for solder reflow and clarify mechanical outline.
J	Released	03/22	Remove MIL-PRF-38535, update company name and website

TTM Technologies
www.ttmtech.com

The information contained herein is believed to be accurate at the time of printing. TTM Technologies reserves the right to make changes to its products or specifications without notice, however and assumes no liability for the use of its products. Please visit our website for the most recent revision of this data sheet.