



**RAD HARD ULTRA LOW
DROPOUT POSITIVE ADJUSTABLE
LINEAR REGULATOR**

5826RH

FEATURES:

- Manufactured using  Space Qualified RH1573 Die
- Replaces IR OMR9605 and IRUH50PA23A
- Total Dose Hardened to 300 Krads(Si) (Method 1019.7 Condition A)
- Ultra Low Dropout for Reduced Power Consumption
- External Shutdown Function
- Latching Overload Protection
- Optimized for 5.0V Input
- 1.265V to (VIN-0.4V) Output Voltage Range
- Output Current Limit
- Available in 2 Lead Form Options: Straight and Gullwing
- Available to DLA SMD 5962F09210
- ELDRS Tested to 100 Krads(Si) (Method 1019.7 Condition D)
- Neutron Tested to 1.0×10^{12} n/cm² (Method 1017.2)

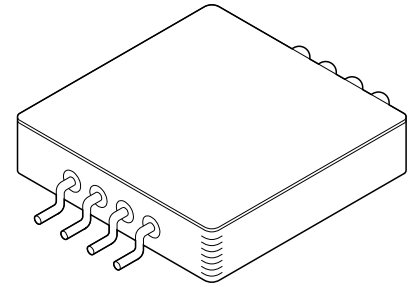

DESCRIPTION:

The MSK5826RH is a rad hard adjustable output linear regulator capable of delivering 3.0 amps of output current. Typical dropout is only 0.30 volts with a 3 amp load. An external shutdown function is ideal for power supply sequencing. This device also has internal latching overload protection. The MSK5826RH is radiation hard and specifically designed for space/satellite applications. The device is packaged in a hermetically sealed space efficient 8 pin flatpack that is electrically isolated from the internal circuitry allowing for direct heat sinking.

EQUIVALENT SCHEMATIC

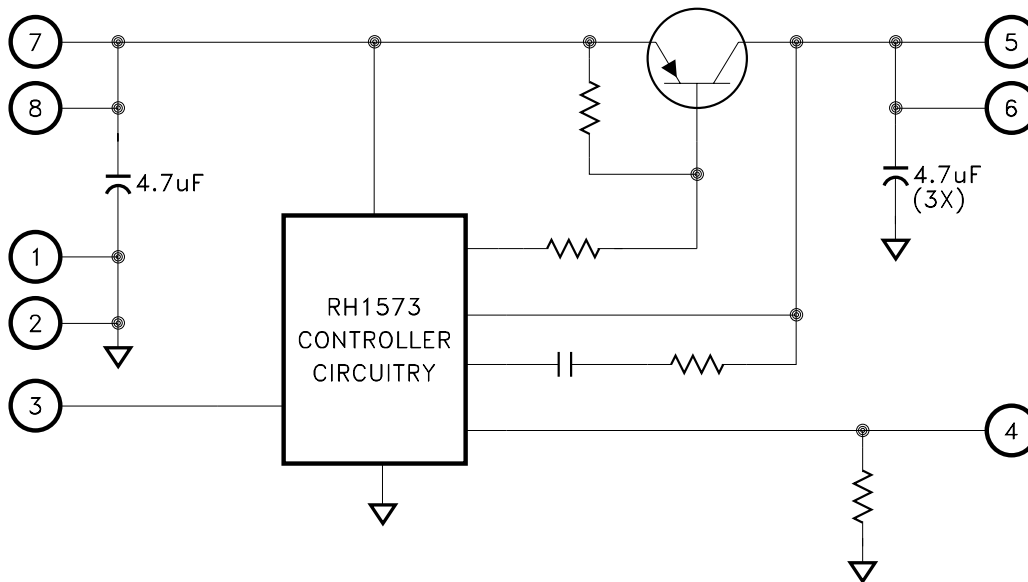

TYPICAL APPLICATIONS

- Satellite System Power Supplies
- Switching Power Supply Post Regulators
- Constant Voltage/Current Regulators
- Microprocessor Power Supplies

PIN-OUT INFORMATION

1	GND	5	VOUT
2	GND	6	VOUT
3	SHUTDOWN	7	VIN
4	ADJUST	8	VIN

CASE = ISOLATED

ABSOLUTE MAXIMUM RATINGS ^⑨

VIN	Supply Voltage	+7V	T _{ST}	Storage Temperature Range .. ^⑫	-65°C to +150°C
VSD	Shutdown Voltage	10V	T _{LD}	Lead Temperature Range	
I _{OUT}	Output Current ^⑦	3.5A		(10 Seconds)	300°C
T _C	Case Operating Temperature Range		P _D	Power Dissipation	See SOA Curve
	MSK5826K/H RH	-55°C to +125°C	T _J	Junction Temperature	150°C
	MSK5826H	-40°C to +85°C			

ELECTRICAL SPECIFICATIONS

Parameter	Test Conditions ^① ^⑩	Group A Subgroup	MSK5826K/H RH			MSK5826RH			Units
			Min.	Typ.	Max.	Min.	Typ.	Max.	
Reference Voltage		1, 2, 3	1.225	1.265	1.305	-	-	-	V
	Post 100KRAD(Si)	1	1.225	-	1.305	1.225	-	1.305	V
	Post 300KRAD(Si)	1	1.225	-	1.310	1.225	-	1.310	V
Line Regulation	4.5V ≤ VIN ≤ 5.5V, I _o = 50mA	1	-0.25	-	+0.25	-0.25	-	+0.25	%/V
		2, 3	-0.5	-	+0.5	-	-	-	%/V
Load Regulation	VIN = 5.0V, 50mA ≤ I _{OUT} ≤ 3.0A	1	-1.0	-	1.0	-1.0	-	1.0	%/A
		2, 3	-2.0	-	2.0	-	-	-	%/A
Input Voltage Range-Operating ^②	I _o = 3.0A	1, 2, 3	4.5	-	6.5	4.5	-	6.5	V
Dropout Voltage ^⑤	I _o = 3.0A. V _{OUT} = 2.5V	1, 2, 3	-	-	0.5	-	-	0.5	V
Current Limit ^⑦	VIN = 5.0V	1, 2, 3	3.0	-	-	3.0	-	-	A
Ripple Rejection ^②	F = 120Hz, I _o = 50mA	4	65	-	-	65	-	-	dB
		4	40	-	-	40	-	-	dB
Shutdown Source Current ^⑧	V _{SHDN} = 5.0V	-	-	200	-	-	200	-	uA
Shutdown Pin Threshold ^⑧	VIN = 5.0V	1, 2, 3	1.0	-	1.6	1.0	-	1.6	V
Output Voltage at Shutdown	VIN = 5.0V, I _o = 50mA V _{SHDN} = +5.0V	1, 2, 3	-0.1	-	+0.1	-0.1	-	+0.1	V
Thermal Resistance ^②	Junction to Case @ 125°C Output Device	-	-	5.0	6.5	-	5.0	6.5	°C/W

NOTES:

- ① Unless otherwise specified, VIN = 5.0V, V_{SHUTDOWN} = 0V and I_{OUT} = 50mA. See figure 2 for typical test circuit.
- ② Guaranteed by design but not tested. Typical parameters are representative of actual device performance but are for reference only.
- ③ Industrial grade devices shall be tested to subgroups 1 and 4 unless otherwise requested.
- ④ Military grade devices ("H" and "K" suffix) shall be 100% tested to subgroups 1,2,3 and 4.
- ⑤ Dropout limited by minimum value of VIN.
- ⑥ Subgroup 1, 4 TC = +25°C
Subgroup 2 TC = +125°C
Subgroup 3 TA = -55°C
- ⑦ Output current limit is dependent upon the values of VIN and V_{OUT}. See application notes "Over Current Latch" and "Current Limit and SOA".
- ⑧ Refer to typical performance curves.
- ⑨ Continuous operation at or above absolute maximum ratings may adversely effect the device performance and/or life cycle.
- ⑩ Pre and post irradiation limits at 25°C, up to 300Krad TID, are identical unless otherwise specified.
- ⑪ Reference DLA SMD 5962F09210 for electrical specification for devices purchased as such.
- ⑫ Internal solder reflow temperature is 180°C, do not exceed.

APPLICATION NOTES

PIN FUNCTIONS

VIN - These pins provide power to all internal circuitry including bias, start-up, thermal limit and overcurrent latch. Input voltage range is 2.9V to 6.5V but the MSK5826RH is optimized for 5.0V input. See MSK5824RH for 3.3V input version.

GND - Internally connected to ground, these pins should be connected externally by the user to the circuit ground.

SHUTDOWN - There are two functions to the SHUTDOWN pin. It may be used to disable the output voltage or to reset a current latch condition. To activate the shutdown/reset functions the user must apply a voltage greater than 1.6V to the SHUTDOWN pin. The voltage applied to the SHUTDOWN pin can be greater than the input voltage. The output voltage will turn on when the SHUTDOWN pin is pulled below the threshold voltage. If the SHUTDOWN pin is not used, it should be connected to ground. It should be noted that with the shutdown pin tied to ground, a current latch condition can only be reset by cycling power off, then on.

VOUT - These are the output pins for the device.

ADJUST - This pin is used to set the output voltage. Connect a resistor between the adjust pin (4) and the output pins (5 and 6) to fix the output voltage at the desired value. Use the following equations to determine the nominal value of the adjust resistor (RADJ).

$$V_{OUT} = V_{REF} \times (1 + \text{RADJ}/1K\Omega)$$

$$\text{RADJ} = (V_{OUT}/V_{REF} - 1) \times 1K\Omega$$

OVERCURRENT LATCH

Overcurrent protection is provided by the MSK5826RH series through the use of a timed latch off circuit. The internal latch timeout is triggered by an overcurrent condition. To allow for start up surge currents, the timeout is approximately 22mS at 25°C. If the overcurrent condition remains at the end of the timeout cycle, the regulator will latch off until the latch is reset. To reset the latch, toggle the shutdown pin high then low or cycle VIN off then back on. At elevated temperatures or input voltages the device may simply limit the output current without activating the latch feature. A thermal limit condition will trigger the latch with no time out delay.

INPUT POWER SUPPLY BYPASSING

The MSK5826RH contains an internal 4.7µF tantalum input capacitor, type CWR19HB475KCBB. The capacitor is rated for 15V maximum applied voltage and has been surge tested in accordance with condition B of MIL-PRF-55365. The system designer must ensure proper de-rating in accordance with their system requirements. To maximize transient response and minimize power supply transients it is recommended that two 47µF tantalum capacitors are connected between VIN and ground. A 0.1µF ceramic capacitor should also be used for high frequency bypassing. See typical application circuit.

OUTPUT CAPACITOR SELECTION

The MSK5826RH contains three internal 4.7µF tantalum output capacitors, type CWR19HB475KCBB. The capacitors are rated for 15V maximum applied voltage and have been surge tested in accordance with condition B of MIL-PRF-55365. The system designer must ensure proper de-rating in accordance with their system requirements. Low ESR output capacitors are required to maintain regulation and stability. Four CWR29FB227 (PN TAZH227K010L) tantalum capacitors in parallel with ceramic decoupling capacitors (0.1µF typical) provides sufficient gain and phase margin for most applications. The maximum ESR specification for the CWR29FB227 capacitor is 180mΩ at 100kHz and is sufficient for many applications. It has been found through full WCCA that screening for a maximum ESR of 57mΩ ensures EOL stability criteria to be met for many applications with the most stringent requirements. The typical ESR of the TAZH227K010L is 49mΩ. Analysis of the final design is recommended to ensure stability requirements are met.

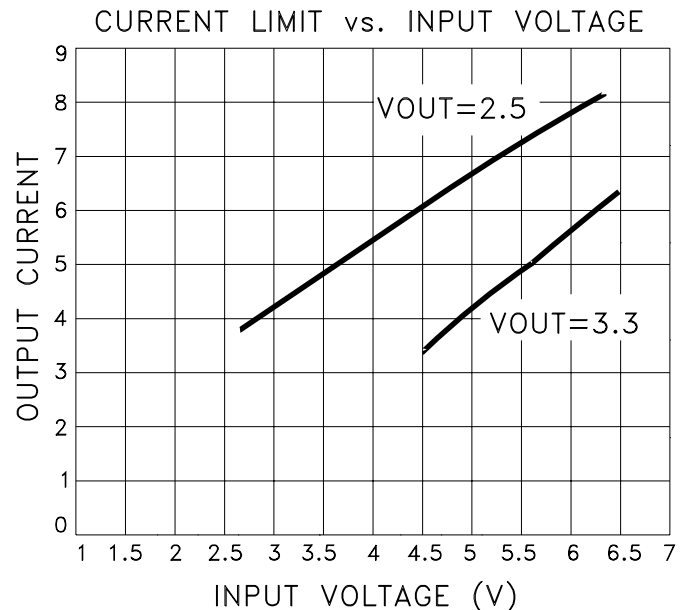

FIGURE 1

CURRENT LIMIT AND SOA

The MSK5826RH current limit function is directly affected by the input and output voltages. Figure 1 illustrates the relationship between VIN and ICL for various output voltages. It is very important for the user to consult the SOA curve when using input voltages which result in current limit conditions beyond 3.5 Amps. When using input voltages which result in current limit above 3.5 Amps, the user must maintain output current within the SOA curve to avoid damage to the device. The current limit is adjusted internally for an input voltage of 5V.

THERMAL LIMITING

The MSK5826RH control circuitry has a thermal shutdown temperature of approximately 150°C. This thermal shutdown can be used as a protection feature, but for continuous operation, the junction temperature of the pass transistor must be maintained below 150°C. Proper heat sink selection is essential to maintain these conditions. Exceeding the thermal limit activates the latch feature of the MSK5826RH. Toggle the shutdown pin high then low or cycle power to reset the latch. See shutdown pin description and overcurrent latch description for more information.

HEAT SINK SELECTION

To select a heat sink for the MSK5826RH, the following formula for convective heat flow may be used.

Governing Equation:

$$T_J = P_D \times (R_{\theta JC} + R_{\theta CS} + R_{\theta SA}) + T_A$$

Where

- T_J = Junction Temperature
- P_D = Total Power Dissipation
- R_{θJC} = Junction to Case Thermal Resistance
- R_{θCS} = Case to Heat Sink Thermal Resistance
- R_{θSA} = Heat Sink to Ambient Thermal Resistance
- T_A = Ambient Temperature

$$\text{Power Dissipation} = (V_{IN} - V_{OUT}) \times I_{OUT}$$

Next, the user must select a maximum junction temperature. The absolute maximum allowable junction temperature is 150°C. The equation may now be rearranged to solve for the required heat sink to ambient thermal resistance (R_{θSA}).

Example:

An MSK5826RH is connected for V_{IN} = +5.0V and V_{OUT} = +3.3V. I_{OUT} is a continuous 3A DC level. The ambient temperature is +25°C. The maximum desired junction temperature is +125°C.

$$\begin{aligned} R_{\theta JC} &= 6.5^\circ\text{C/W and } R_{\theta CS} = 0.15^\circ\text{C/W for most thermal greases} \\ \text{Power Dissipation} &= (5.0\text{V} - 3.3\text{V}) \times (3\text{A}) \\ &= 5.1 \text{ Watts} \end{aligned}$$

Solve for R_{θSA}:

$$\begin{aligned} R_{\theta SA} &= \left[\frac{125^\circ\text{C} - 25^\circ\text{C}}{5.1\text{W}} \right] - 6.5^\circ\text{C/W} - 0.15^\circ\text{C/W} \\ &= 12.9^\circ\text{C/W} \end{aligned}$$

In this example, a heat sink with a thermal resistance of no more than 12.9°C/W must be used to maintain a junction temperature of no more than 125°C.

TYPICAL APPLICATIONS CIRCUIT

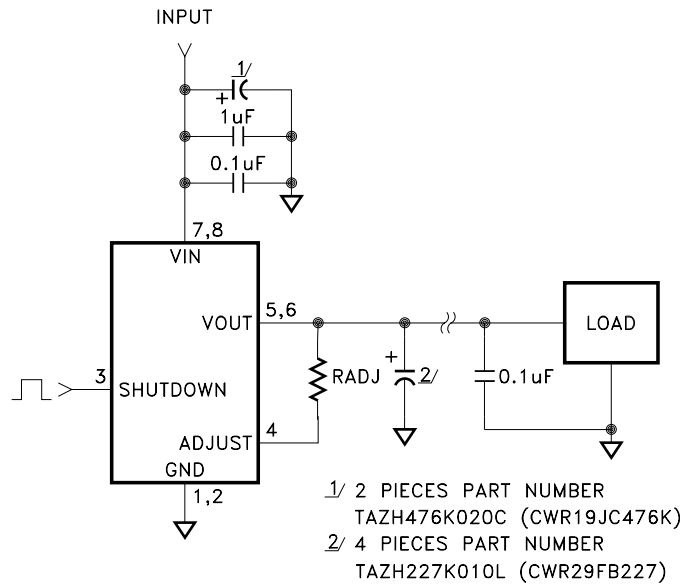

FIGURE 2

START UP CURRENT

The MSK5826RH sinks increased current during startup to bring up the output voltage. Reference the "Saturated Drive Current vs. Input Voltage" graph in the typical performance curves of this data sheet and the "Understanding Startup Surge Current With RH1573 Based Rad Hard LDO Regulators" application note in the application notes section of the TTM Technologies Web site for more information.

TOTAL DOSE RADIATION TEST PERFORMANCE

Radiation performance curves for TID, Neutron and ELDRS testing have been generated for all radiation testing performed by TTM Technologies. These curves show performance trends throughout the TID test process and are located in the MSK5826RH radiation test report. The complete radiation test report is available in the RAD HARD PRODUCTS section on the TTM Technologies website.

TYPICAL PERFORMANCE CURVES

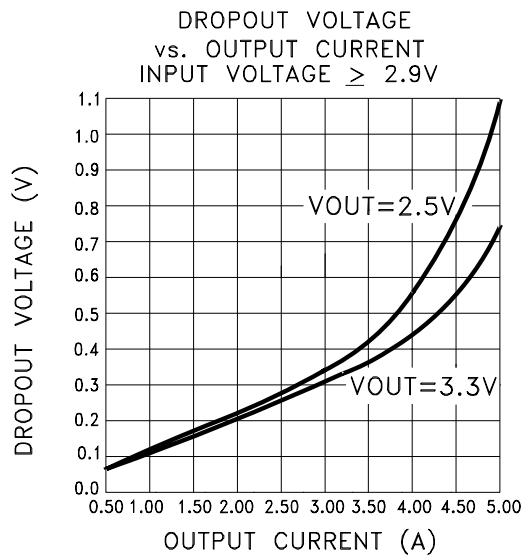
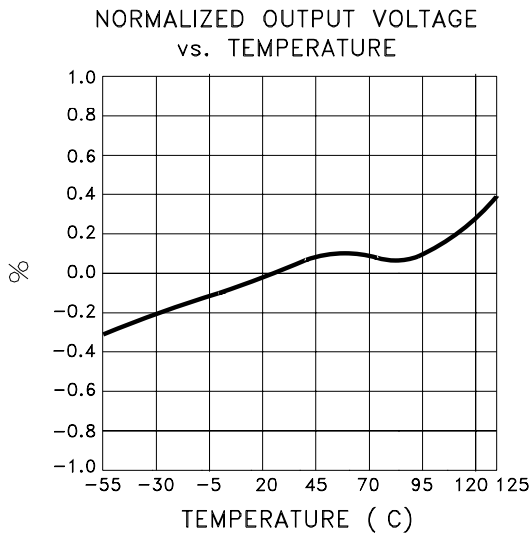
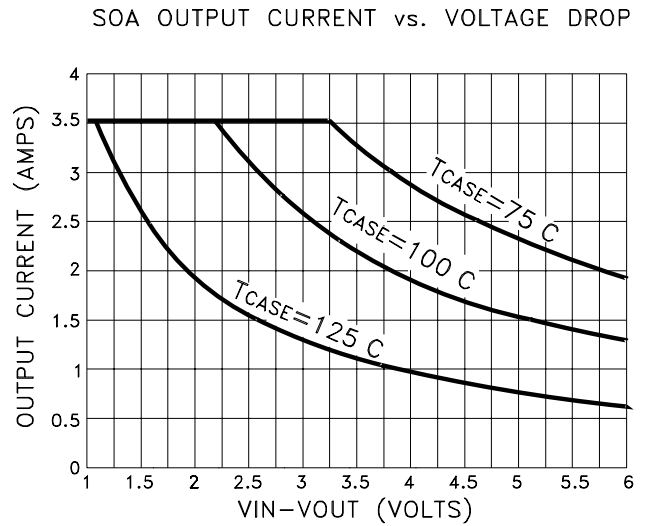
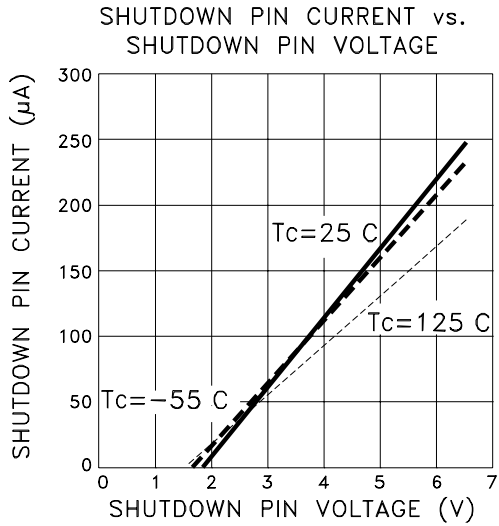
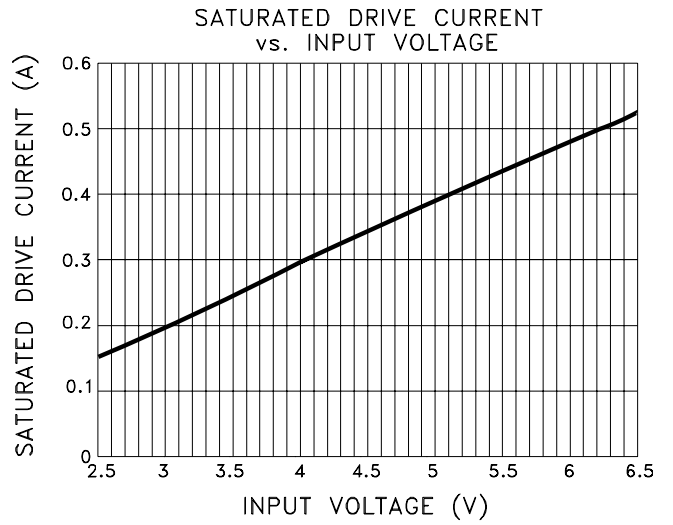
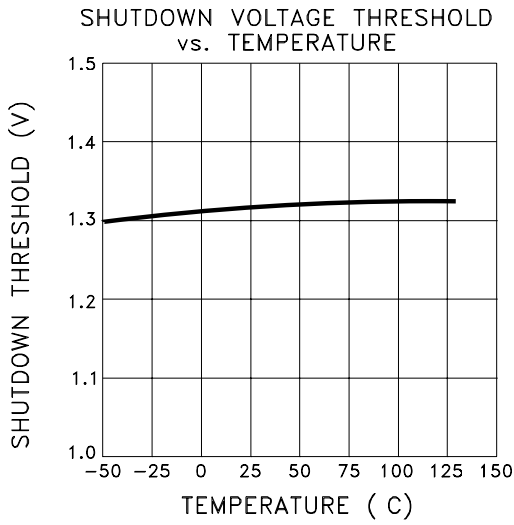

MECHANICAL SPECIFICATIONS

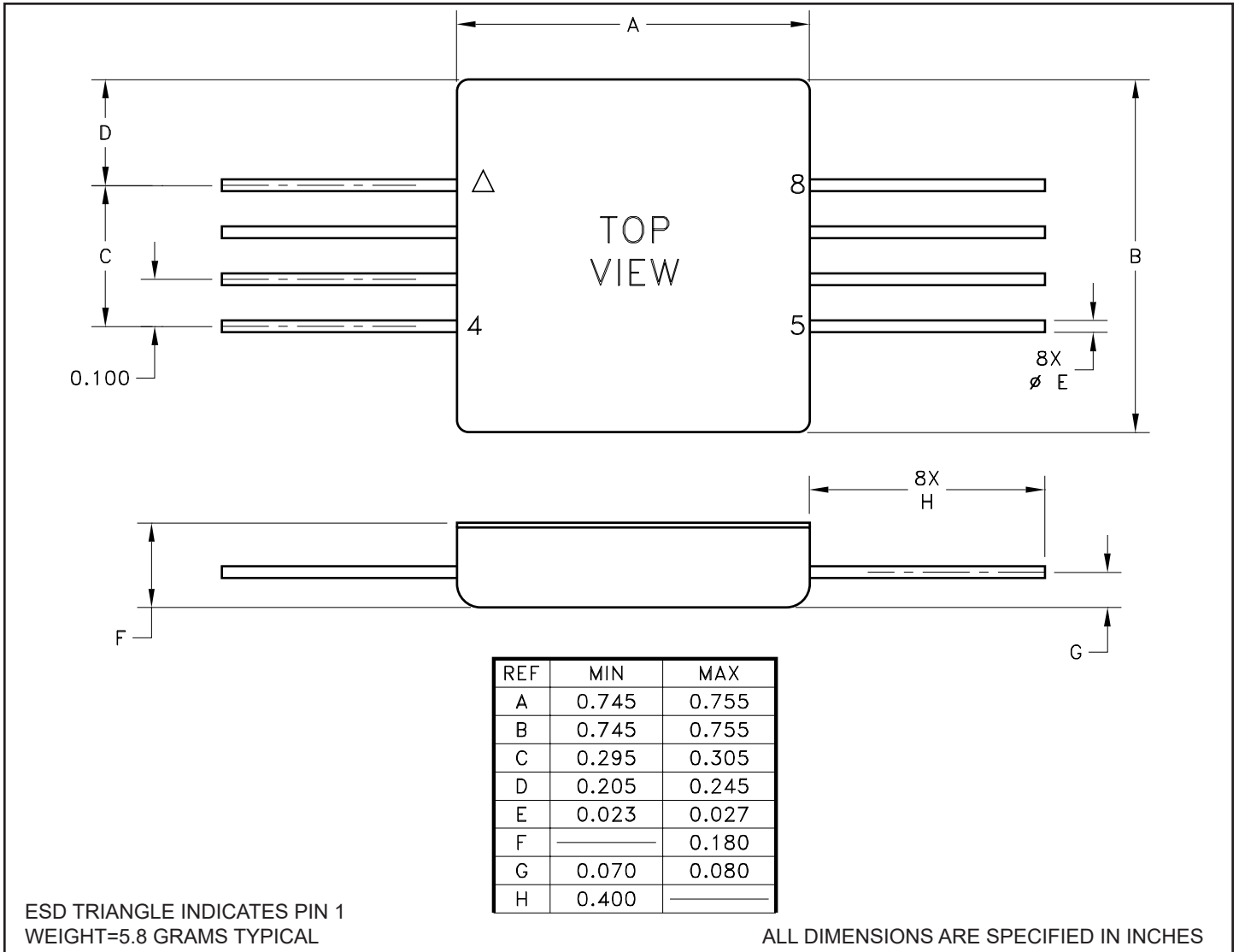

ORDERING INFORMATION

MSK5826 K RH

LEAD CONFIGURATIONS
 BLANK = STRAIGHT
RADIATION HARDENED
SCREENING
 BLANK = INDUSTRIAL; H = MIL-PRF-38534 CLASS H;
 K = MIL-PRF-38534 CLASS K
GENERAL PART NUMBER

The above example is a Class K regulator with straight leads.
 NOTE: See DLA SMD 5962F09210 for DLA part number options.

MECHANICAL SPECIFICATIONS CONT'D

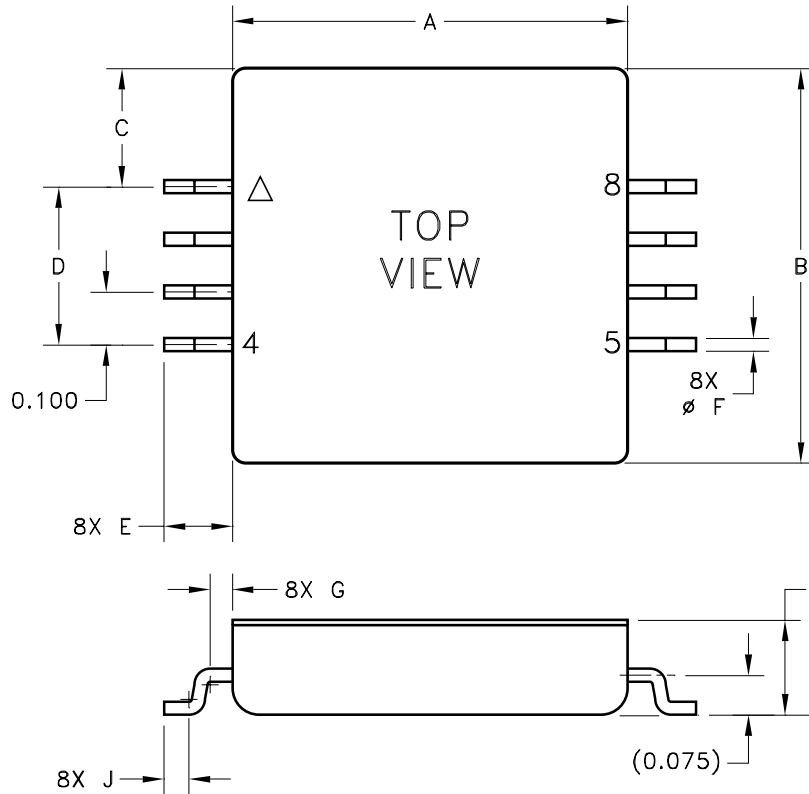

REF	MIN	MAX
A	0.745	0.755
B	0.745	0.755
C	0.205	0.245
D	0.295	0.305
E	0.110	0.150
F	0.023	0.027
G	0.040	0.065
H		0.180
J	0.040	0.065
K	-0.010	0.010

NOTE: 'K' IS MEASURED FROM THE BOTTOM OF THE PIN TO THE BOTTOM OF THE CASE

ESD TRIANGLE INDICATES PIN 1
WEIGHT=5.5 GRAMS TYPICAL

ALL DIMENSIONS ARE SPECIFIED IN INCHES

ORDERING INFORMATION

MSK5826 K RH G

LEAD CONFIGURATIONS

G = GULL WING

RADIATION HARDENED

SCREENING

BLANK = INDUSTRIAL; H = MIL-PRF-38534 CLASS H;

K = MIL-PRF-38534 CLASS K

GENERAL PART NUMBER

The above example is a Class K regulator with gull wing formed leads.

NOTE: See DLA SMD 5962F09210 for DLA part number options.

REVISION HISTORY

REV	STATUS	DATE	DESCRIPTION
H	Released	06/14	Add shutdown pin to absolute maximum ratings and comment in shutdown pin description, new note for solder reflow and clarify mechanical outline.
J	Released	03/22	Remove MIL-PRF-38535, update company name and website

TTM Technologies
www.ttmtech.com

The information contained herein is believed to be accurate at the time of printing. TTM Technologies reserves the right to make changes to its products or specifications without notice, however and assumes no liability for the use of its products. Please visit our website for the most recent revision of this data sheet.