



**RAD HARD POSITIVE,  
3 AMP, LOW DROPOUT  
ADJ VOLTAGE REGULATOR**

**5971RH**

**FEATURES:**

- Manufactured using  **LINEAR** TECHNOLOGY Space Qualified RH1085 Die
- Total Dose Hardened to 100 Krad(Si) (Method 1019.7 Condition A)
- Low Dropout Voltage
- Internal Short Circuit Current Limit
- Output Voltage is Adjustable with 2 External Resistors
- Output Current Capability to 3 Amps
- Internal Thermal Overload Protection
- Available in 3 Lead Form Options: Straight, Up and Down (TO257)
- Available to DSCC SMD 5962R09212

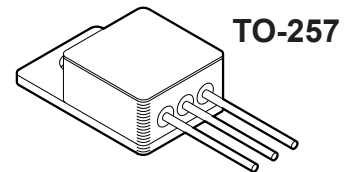
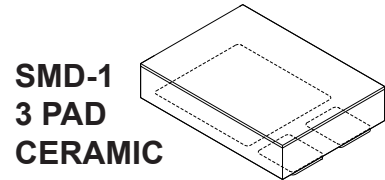

**DESCRIPTION:**

The MSK 5971RH offers low dropout voltage while offering radiation tolerance for space applications. This, combined with the low  $\theta_{JC}$ , allows increased output current while providing exceptional device efficiency. Because of the increased efficiency, a small hermetic 3 pin package either SMD-1 or TO-257, can be used providing maximum performance while occupying minimal board space. Output voltage is selected by the user through the use of 2 external resistors. Additionally, the regulator offers internal short circuit current and thermal limiting, which allows circuit protection and eliminates the need for external components and excessive derating. The MSK 5971RH is available in two space saving package options; the 3 pin power surface mount SMD-1 and the TO-257 package with 3 lead form options: straight, up and down.

**EQUIVALENT SCHEMATIC**

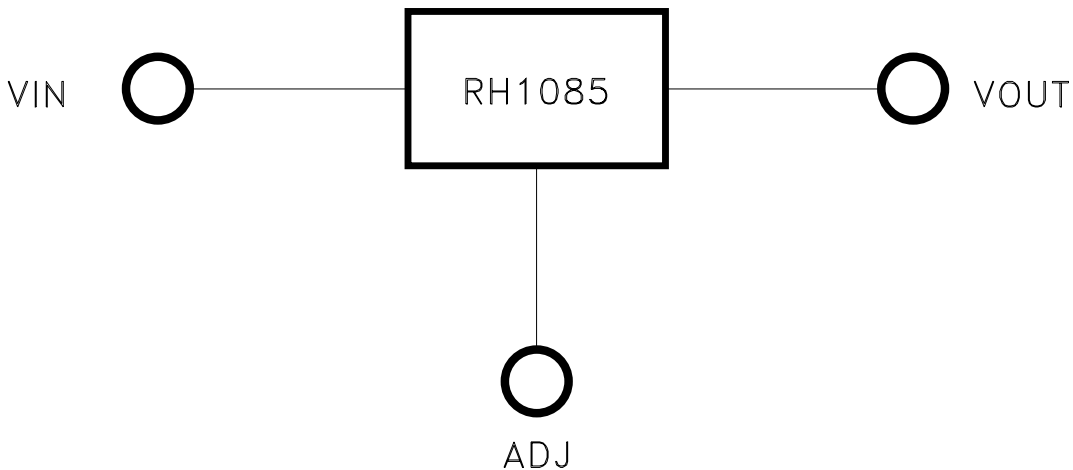

**TYPICAL APPLICATIONS**

- High Efficiency Linear Regulators
- Constant Voltage/Current Regulators
- System Power Supplies
- Switching Power Supply Post Regulators

**PIN-OUT INFORMATION**

TO-257	SMD-1
1 ADJ	1 ADJ
2 VOUT	2 VIN
3 VIN	3 VOUT

 and the Linear Technology logo are registered trademarks and RH1085 is a copyright of Linear Technology Corporation

## ABSOLUTE MAXIMUM RATINGS <sup>⑧</sup>

±VIN	Input Voltage (WRT VOUT).....	30V	T <sub>ST</sub>	Storage Temperature Range..... <sup>⑪</sup>	-65°C to +150°C
P <sub>D</sub>	Power Dissipation.....	Internally Limited	T <sub>LD</sub>	Lead Temperature Range (10 Seconds).....	300°C
I <sub>OUT</sub>	Output Current..... <sup>⑦</sup>	3A	T <sub>C</sub>	Case Operating Temperature MSK5971RH.....	-40°C to +85°C
T <sub>J</sub>	Junction Temperature.....	+150°C		MSK5971K/HRH.....	-55°C to +125°C

## ELECTRICAL SPECIFICATIONS

Parameter	Test Conditions <sup>① ③ ⑨</sup>	Group A Subgroup	MSK5971K/H RH			MSK5971RH			Units
			Min.	Typ.	Max.	Min.	Typ.	Max.	
Reference Voltage	I <sub>OUT</sub> = 10mA VIN = V <sub>OUT</sub> +3V	1	1.238	1.250	1.262	1.225	1.250	1.270	V
		2,3	1.225	1.250	1.270	-	-	-	V
	Post Radiation	1	1.205	1.24	1.262	1.205	1.224	1.270	V
Dropout Voltage	10mA ≤ I <sub>OUT</sub> ≤ 3A ΔV <sub>OUT</sub> = 1%	1	-	1.3	1.65	-	1.3	1.65	V
Line Regulation	I <sub>OUT</sub> =10mA (V <sub>OUT</sub> +3V) ≤ VIN ≤ (V <sub>OUT</sub> +15V)	1	-0.5	0.1	0.5	-	0.1	0.6	%
		2,3	-0.75	0.2	0.75	-	-	-	%
Load Regulation	VIN = V <sub>OUT</sub> +3V 10mA ≤ I <sub>OUT</sub> ≤ 3A	1	-1.0	0.2	1.0	-	0.2	2.0	%
		2,3	-2.0	0.3	2.0	-	-	-	%
Short Circuit Current <sup>⑦</sup>	VIN = V <sub>OUT</sub> +5	1	3.0	4.2	-	3.0	4.2	-	A
		Post Radiation	1	3.0	4.1	-	3.0	4.1	-
Ripple Rejection <sup>②</sup>	I <sub>OUT</sub> = 3A; C <sub>OUT</sub> = 25μF; f = 120Hz	-	-	75	-	-	75	-	dB
Thermal Resistance <sup>②</sup>	Junction to Case @ 125°C TO-257 Package	-	-	3.0	3.5	-	3.0	3.5	°C/W
Thermal Resistance <sup>②</sup>	Junction to Case @ 125°C SMD-1 Package	-	-	2.0	2.5	-	2.0	2.5	°C/W

### NOTES:

- ① Output is decoupled to ground using 10μF low ESR tantalum capacitor unless otherwise specified.
- ② Guaranteed by design but not tested. Typical parameters are representative of actual device performance but are for reference only. Not applicable to post irradiation performance.
- ③ All output parameters are tested using a low duty cycle pulse to maintain T<sub>J</sub> = T<sub>C</sub>.
- ④ Industrial grade and shall be tested to subgroup 1 unless otherwise specified.
- ⑤ Military grade devices ("H" and "K" suffix) shall be 100% tested to subgroups 1,2 and 3.
- ⑥ Subgroup 1 TA = TC = +25°C  
Subgroup 2 TA = TC = +125°C  
Subgroup 3 TA = TC = -55°C
- ⑦ The output current limit function provides protection from transient overloads but it may exceed the maximum continuous rating. Continuous operation in current limit may damage the device. For compliance with MIL-STD 833 revision C current density specifications, the MSK 5971RH is derated to 2 amps.
- ⑧ Continuous operation at or above absolute maximum ratings may adversely effect the device performance and/or life cycle.
- ⑨ Pre and Post irradiation limits at 25°C, up to 100Krad TID, are identical unless otherwise specified. Post irradiation performance is guaranteed by design with a 2X radiation design margin.
- ⑩ Reference DSCC SMD 5962R09212 for electrical specification for devices purchased as such.
- ⑪ Internal solder reflow temperature is 180°C, do not exceed.

## APPLICATION NOTES

### BYPASS CAPACITORS

Minimum requirement for output capacitance is 10µF, low ESR tantalum. A 22µF low ESR (0.5-2 ohm) tantalum capacitor attached close to the regulator's output will ensure stability in most applications. This will effectively lower the regulator's output impedance, increase transient response and eliminate any oscillations that are normally associated with low dropout regulators. Additional bypass capacitors can be used at the remote load locations to further improve regulation. These can be either of the tantalum or the electrolytic variety. Unless the regulator is located very close to the power supply filter capacitor(s), a 4.7µF minimum low ESR (0.5-2 ohm) tantalum capacitor should also be added to the regulator's input. An electrolytic may also be substituted if desired. When substituting electrolytic in place of tantalum capacitors, a good rule of thumb to follow is to increase the size of the electrolytic by a factor of 10 over the tantalum value.

### OUTPUT VOLTAGE

The MSK 5971RH develops a 1.250 Volt reference between the output pin and the adjust pin. A resistor, R1, is placed between the output and adjust pins, causing current to flow through R1 and down through R2, setting the output voltage. R1 may be chosen to sink the minimum required load current of 10mA. Refer to Figure 1 for connections and Vout calculation.

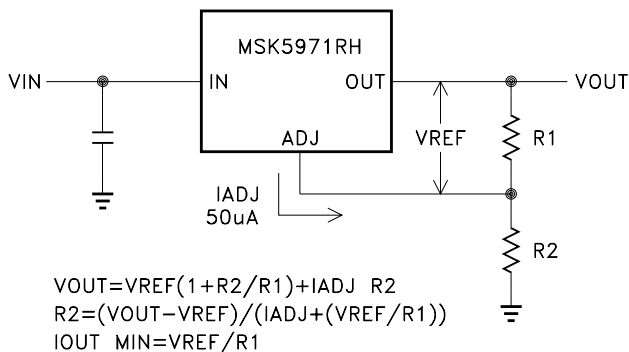

FIGURE 1

### LOAD REGULATION

With a three-terminal device, it is not possible to provide true remote load sensing. The resistance of the connection to the load will limit the load regulation of the device. The best load regulation will be achieved when the top of the divider is connected to the pin as close to the case of the MSK 5971RH as possible and the bottom of the divider as close to the load as possible. This will effectively reduce the effect of the parasitic line resistance on the load regulation of the device.

Refer to Figure 2 for proper connections.

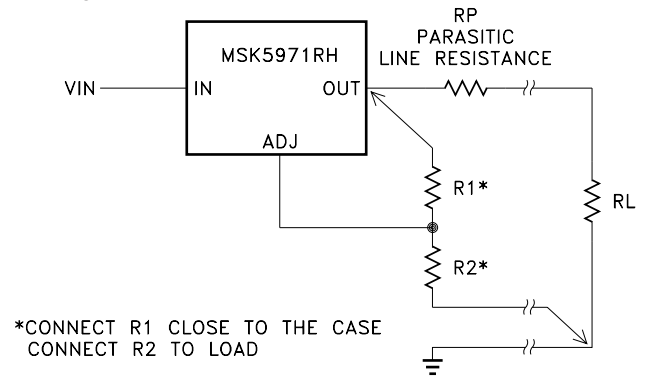

FIGURE 2

### RIPPLE REJECTION

The typical curve for ripple rejection is shown with the adjust pin bypassed as shown in Figure 3. For proper bypassing and ripple rejection approaching the values of the curve, the impedance of the adjust pin capacitor at the ripple frequency should be less than the value of R1. The value of the adjust pin capacitor is a function of the input ripple frequency. For instance, if R1=100Ω, at 120Hz the adjust pin capacitor should be 25µF. At 10KHz only 0.22µF is required.

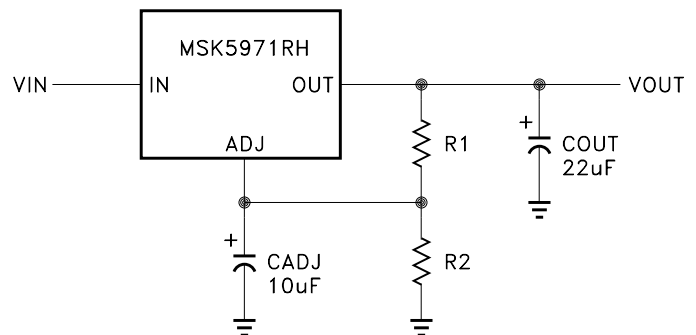

FIGURE 3

## OVERLOAD SHUTDOWN

The regulator features both power and thermal overload protection. When the maximum power dissipation is not exceeded, the regulator will current limit slightly above its 3 amp rating. As the Vin-Vout voltage increases, however, shutdown occurs in relation to the maximum power dissipation curve. If the device heats enough to exceed its rated die junction temperature due to excessive ambient temperature, improper heat sinking etc., the regulator also shuts down until an appropriate junction temperature is maintained. It should also be noted that in the case of an extreme overload, such as a sustained direct short, the device may not be able to recover. In these instances, the device must be shut off and power reapplied to eliminate the shutdown condition.

## TOTAL DOSE RADIATION TEST PERFORMANCE

Radiation performance curves for TID testing will be generated for all radiation testing performed by MS Kennedy. These curves will show performance trends throughout the TID test process and can be located in the MSK 5971RH radiation test report. The complete radiation test report will be available in the RAD HARD PRODUCTS section on the Anaren website.

[www.anaren.com/msk](http://www.anaren.com/msk)

## HEAT SINKING

To determine if a heat sink is required for your application and if so, what type, refer to the thermal model and governing equation below.

Governing Equation:  $T_j = P_d \times (R_{\theta jc} + R_{\theta cs} + R_{\theta sa}) + T_a$

### WHERE

$T_j$  = Junction Temperature  
 $P_d$  = Total Power Dissipation  
 $R_{\theta jc}$  = Junction to Case Thermal Resistance  
 $R_{\theta cs}$  = Case to Heat Sink Thermal Resistance  
 $R_{\theta sa}$  = Heat Sink to Ambient Thermal Resistance  
 $T_c$  = Case Temperature  
 $T_a$  = Ambient Temperature  
 $T_s$  = Heat Sink Temperature

### EXAMPLE:

This example demonstrates an analysis of the TO-257 package with the regulator operating at one-half of its maximum rated output current.

Conditions for MSK 5971RH:

VIN = +8.0V; Iout = +1.5A

- 1) Assume 45° heat spreading model.
- 2) Find positive regulator power dissipation:

$$\begin{aligned} P_d &= (V_{IN} - V_{OUT}) (I_{out}) \\ P_d &= (8-5)(1.5) \\ &= 4.5W \end{aligned}$$

- 3) For conservative design, set  $T_j = +125^\circ\text{C}$  Max.
- 4) For this example, worst case  $T_a = +90^\circ\text{C}$ .
- 5)  $R_{\theta jc} = 3.5^\circ\text{C/W}$  from the Electrical Specification Table.
- 6)  $R_{\theta cs} = 0.15^\circ\text{C/W}$  for most thermal greases.
- 7) Rearrange governing equation to solve for  $R_{\theta sa}$ :

$$\begin{aligned} R_{\theta sa} &= ((T_j - T_a)/P_d) - (R_{\theta jc}) - (R_{\theta cs}) \\ &= (125^\circ\text{C} - 90^\circ\text{C})/4.5W - 3.5^\circ\text{C/W} - 0.15^\circ\text{C/W} \\ &= 4.1^\circ\text{C/W} \end{aligned}$$

In this case the result is 4.1°C/W. Therefore, a heat sink with a thermal resistance of no more than 4.1°C/W must be used in this application to maintain regulator circuit junction temperature under 125°C.

# TYPICAL PERFORMANCE CURVES

DROPOUT VOLTAGE vs. OUTPUT CURRENT

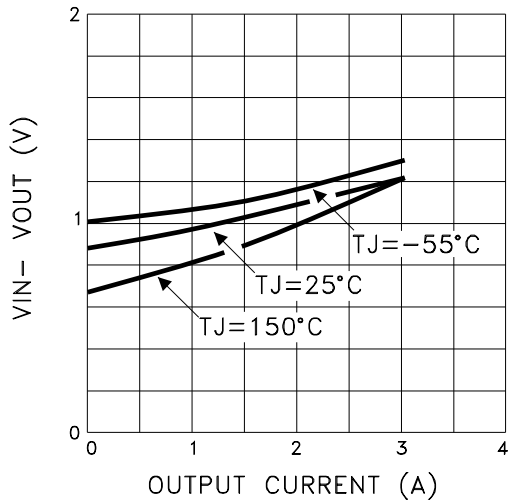

MINIMUM OPERATING CURRENT

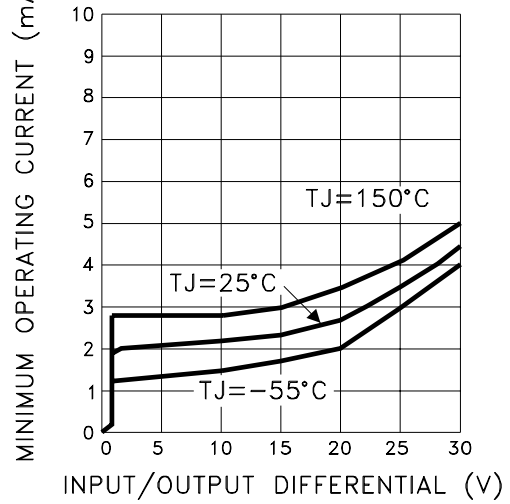

INTERNAL CURRENT LIMIT vs. VIN-VOUT

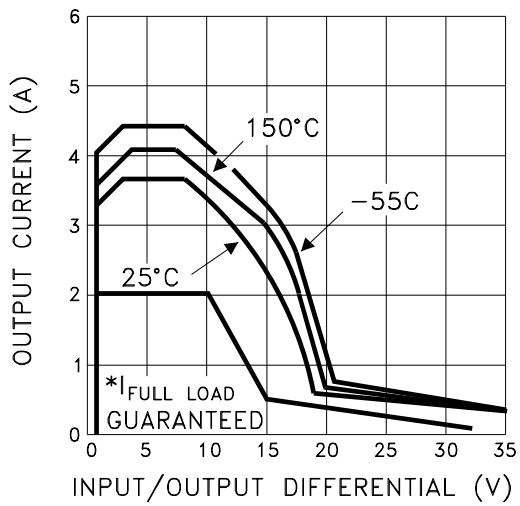

POWER DISSIPATION vs. TEMPERATURE

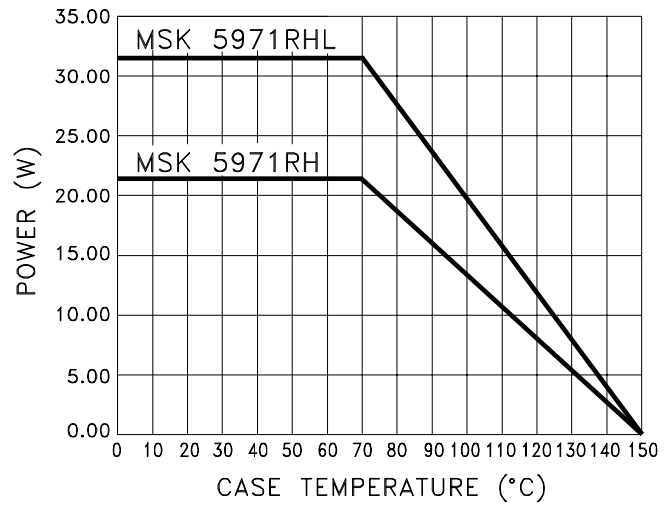

\*REFERENCE NOTE 7 ON PAGE 2

RIPPLE REJECTION vs. FREQUENCY

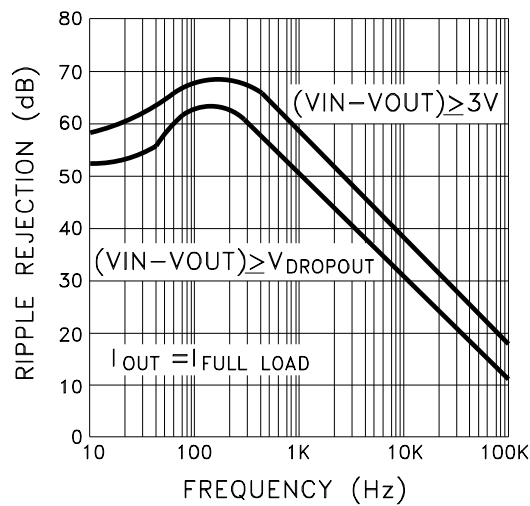

# MECHANICAL SPECIFICATIONS

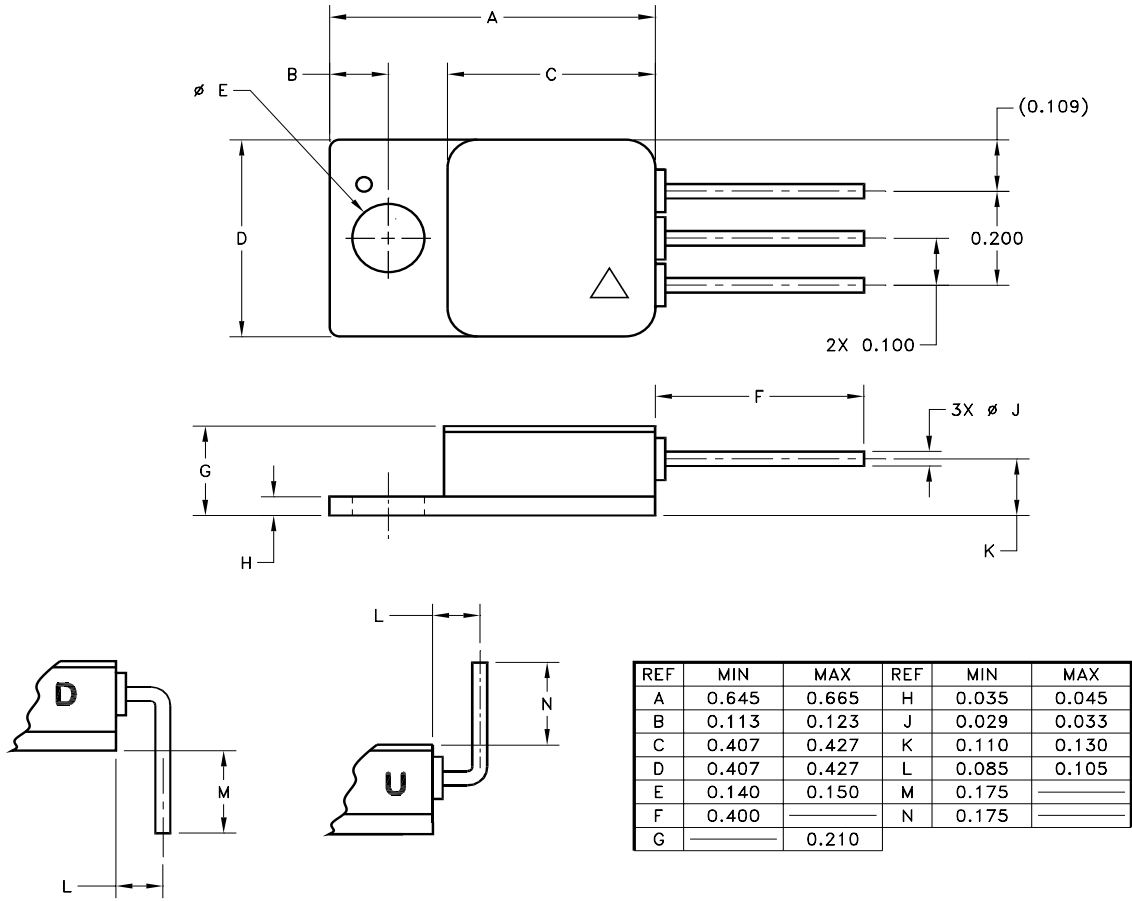

ESD TRIANGLE INDICATES PIN 1  
WEIGHT = 3.2 GRAMS TYPICAL

ALL DIMENSIONS ARE SPECIFIED IN INCHES

## ORDERING INFORMATION

MSK5971 H RH U

**LEAD CONFIGURATIONS**

S = STRAIGHT; U = BENT UP; D = BENT DOWN

**RADIATION HARDENED**

**SCREENING**

BLANK = INDUSTRIAL; H = MIL-PRF-38534 CLASS H;

K = MIL-PRF-38534 CLASS K

**GENERAL PART NUMBER**

The above example is an adjustable Class K regulator with leads bent up.  
Ordering information for the 3 pad ceramic SMD-1 package is contained on the next page.

NOTE: See DSCC SMD 5962R09212 for DSCC part number options.

# MECHANICAL SPECIFICATIONS

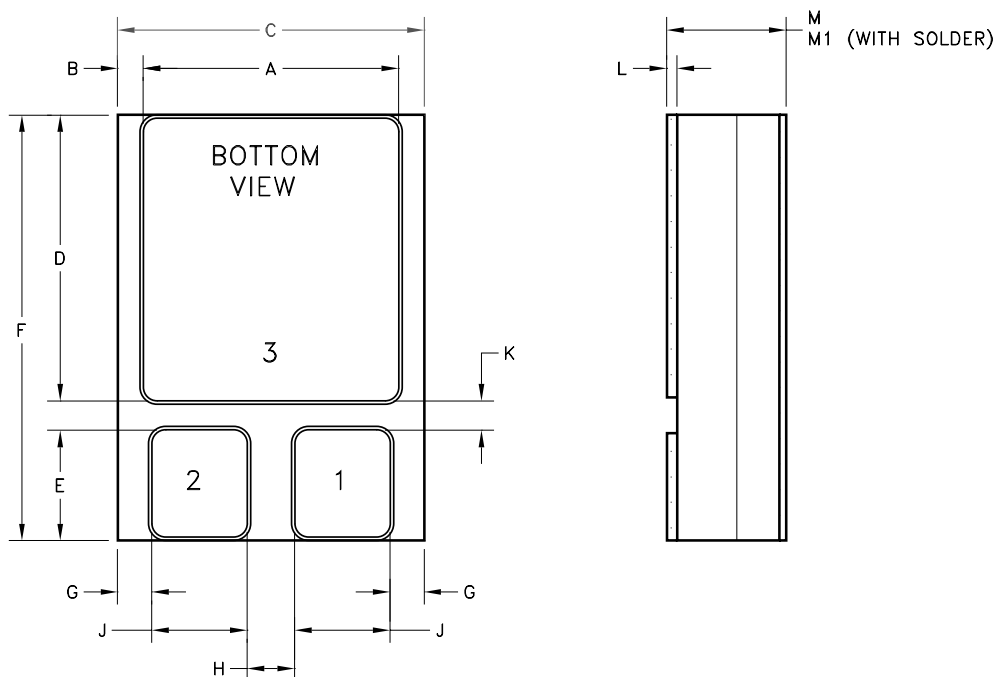

REF	MIN	MAX	REF	MIN	MAX
A	0.365	0.385	H	0.035	—
B	0.032	0.042	J	0.130	0.150
C	0.440	0.460	K	0.030	—
D	0.405	0.425	L	0.012	0.018
E	0.152	0.162	M	—	0.130
F	0.615	0.635	M1	—	0.135
G	0.045	0.055			

ESD TRIANGLE INDICATES PIN 1  
WEIGHT = 3.2 GRAMS TYPICAL

ALL DIMENSIONS ARE SPECIFIED IN INCHES

## ORDERING INFORMATION

MSK5971 K RH L

3 PAD CERAMIC SMD-1 PACKAGE  
RADIATION HARDENED  
SCREENING

BLANK = INDUSTRIAL; H = MIL-PRF-38534 CLASS H;  
K = MIL-PRF-38534 CLASS K

GENERAL PART NUMBER

The above example is an adjustable Class K regulator.

NOTE: See DSCC SMD 5962R09212 for DSCC part number options.

## REVISION HISTORY

REV	STATUS	DATE	DESCRIPTION
H	Released	07/14	Update format, assign form number and add internal solder note.
J	Released	09/17	Update parameters to better correlate to manufacturer's pre and post rad specs.
K	Released	11/17	Change output current maximum to 3A
L	Released	07/18	Update mechanical outline to show ceramic seals

ANAREN, MSK Products  
[www.anaren.com/msk](http://www.anaren.com/msk)

---

The information contained herein is believed to be accurate at the time of printing. Anaren, MSK products reserves the right to make changes to its products or specifications without notice, however and assumes no liability for the use of its products.  
Please visit our website for the most recent revision of this datasheet.