

ABSOLUTE MAXIMUM RATINGS

V_{IN} Input Voltage (V_{IN} - V_{OUT}).....+40VDC
 P_D Power Dissipation.....Internally Limited
 I_{OUT} Output Current.....1.5A
 T_J Junction Temperature.....+150°C

T_{ST} Storage Temperature Range..... ⑪.....-65°C to +150°C
 T_{LD} Lead Temperature Range
 (10 Seconds).....300°C
 T_c Case Operating Temperature Range
 MSK5972RH.....-40°C to +85°C
 MSK5972(K/H)RH.....-55°C to +125°C

ELECTRICAL SPECIFICATIONS

Parameter	Test Conditions ⑨	Group A Subgroup	MSK 5972K/HRH			MSK 5972RH			Units
			Min.	Typ.	Max.	Min.	Typ.	Max.	
Reference Voltage	3V ≤ (V _{IN} - V _{OUT}) ≤ 40V I _{OUT} = 10mA	1	1.20	1.25	1.30	1.15	1.25	1.35	V
		2, 3	1.20	-	1.30	-	-	-	V
Line Regulation	3V ≤ (V _{IN} - V _{OUT}) ≤ 40V I _{OUT} = 10mA	1	-0.02	-	+0.02	-0.02	-	+0.02	%/V
		2, 3	-0.05	-	+0.05	-	-	-	%/V
		Post 100KRAD(Si)	1	-0.03	-	+0.03	-0.03	-	+0.03
Adjust Pin Current	2.5V ≤ (V _{IN} - V _{OUT}) ≤ 40V I _{OUT} = 10mA	1	-	40	100	-	40	100	uA
		2, 3	-	-	100	-	-	-	uA
Adjust Pin Current Change	2.5V ≤ (V _{IN} - V _{OUT}) ≤ 40V I _{OUT} = 10mA	1	-5.0	0.1	+5.0	-5.0	0.1	+5.0	uA
		2, 3	-6.0	-	+6.0	-	-	-	uA
Load Regulation	V _{IN} = V _{OUT} + 3V, V _{OUT} ≤ 5 10mA ≤ I _{OUT} ≤ 1.5A	1	-20	11.5	+20	-25	11.5	+25	mV
		2, 3	-50	-	+50	-	-	-	mV
		Post 100KRAD(Si)	1	-60	-	+60	-60	-	+60
Current Limit ⑦	V _{IN} = V _{OUT} + 5V	1	1.5	2.3	-	1.5	2.3	-	A
		2, 3	1.5	-	-	-	-	-	A
Ripple Rejection ②	V _{OUT} = 10V, F = 120Hz, C _{adj} = 10uF	4	66	-	-	66	-	-	dB
Minimum Load Current ②	(V _{IN} - V _{OUT}) = 40V	1	-	-	5	-	-	5	mA
Thermal Resistance ②	Junction to Case @ 125°C TO-257 Package	-	-	4.2	4.5	-	4.2	4.5	°C/W
Thermal Resistance ②	Junction to Case @ 125°C SMD-1 Package	-	-	3.0	3.5	-	3.0	3.5	°C/W

NOTES:

- ① Output is decoupled to ground using 10μF low ESR capacitors.
- ② Guaranteed by design but not tested. Typical parameters are representative of actual device performance but are for reference only.
- ③ All output parameters are tested using a low duty cycle pulse to maintain T_J = T_C.
- ④ Industrial grade and devices shall be tested to subgroup 1 unless otherwise specified.
- ⑤ Military grade devices ("H" and "K" suffix) shall be 100% tested to subgroups 1, 2 and 3.
- ⑥ Subgroup 1 TA = TC = +25°C
 2 TA = TC = +125°C
 3 TA = TC = -55°C
- ⑦ The output current limit function provides protection from transient overloads but it may exceed the maximum continuous rating. Continuous operation in current limit may damage the device.
- ⑧ Continuous operation at or above absolute maximum ratings may adversely effect the device performance and/or life cycle.
- ⑨ Pre and Post irradiation limits at 25°C, up to 100Krad TID, are identical unless otherwise specified.
- ⑩ Reference DLA SMD 5962R09213 for electrical specification for devices purchased as such.
- ⑪ Internal solder reflow temperature is 180°C, do not exceed.

APPLICATION NOTES

OUTPUT VOLTAGE

The MSK5972RH develops a nominal 1.25V reference voltage between the output and adjustment terminal. The reference voltage is dropped across program resistor R1 and, since the voltage is constant, a constant current then flows through the output set resistor R2. Since the current from the adjustment terminal represents an error in the programmed output voltage, the MSK5972RH was designed to minimize IADJ and make it very constant with line and load changes. To do this, all quiescent operating current is returned to the output establishing a minimum load current requirement. If there is insufficient load on the output, the output will rise. Figure 1 shows the output voltage calculations.

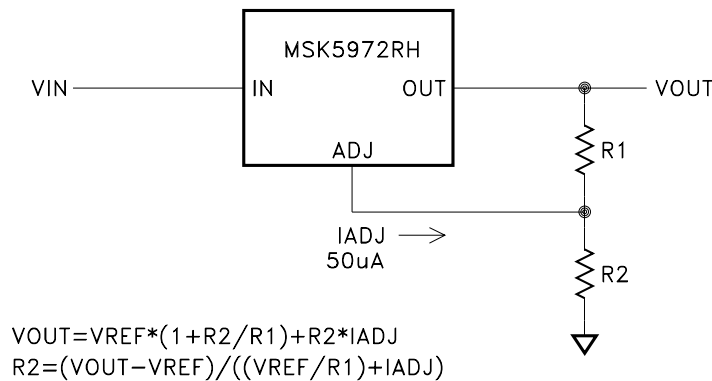

FIGURE 1

EXTERNAL CAPACITORS

Input bypassing with a 1uF tantalum in parallel with a 0.1uF ceramic on the input is suitable in most applications. To maximize transient response and minimize input supply transients more input capacitance can be added. The adjustment terminal can be bypassed to ground on the MSK5972RH to improve ripple rejection. This bypass capacitor prevents ripple from being amplified at higher output voltages. The impedance of the adjust pin capacitor at the ripple frequency should be less than the value of R1. For most application a 10uF bypass capacitor will provide sufficient ripple rejection at any output level. Increases over 10uF do not appreciably improve the ripple rejection at frequencies above 120Hz. Output bypassing with 1uF low ESR tantalum in parallel with a 0.1uF ceramic attached as close to the regulator's output as possible is best. This will effectively lower the regulator's output impedance, increase transient response and eliminate any oscillations. Any increase of the load capacitance larger than 1uF will merely improve the loop stability and output impedance. See Figure 3 for typical application schematic.

LOAD REGULATION

The MSK5972RH is capable of providing extremely good load regulation but a few precautions are needed to obtain maximum performance. The current set resistor connected between the adjustment terminal and the output terminal should be tied directly to the output pin as close to the case of the regulator as possible rather than near the load. This eliminates package pin and trace drops from appearing effectively in series with the reference and

degrading regulation. For example, a 5V regulator with 0.05Ω resistance between the regulator and the current set resistor will droop 225mV at 1A due to package pin and trace resistance. The amount of droop can be calculated as follows:

$$(V_{OUT} \text{ at } 5\text{mA}) - (1.250 - (0.05\Omega * I_L)) * (1 + R2/R1).$$

The ground of R2 can be returned near the ground of the load to provide remote ground sensing and improve load regulation. Figure 2A shows the effect of resistance between the regulator and 240Ω set resistor.

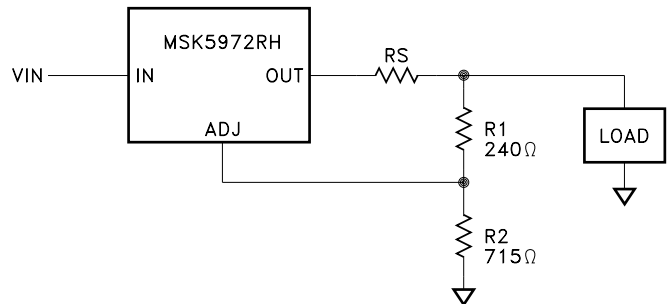

FIGURE 2A
(Degraded Regulation)

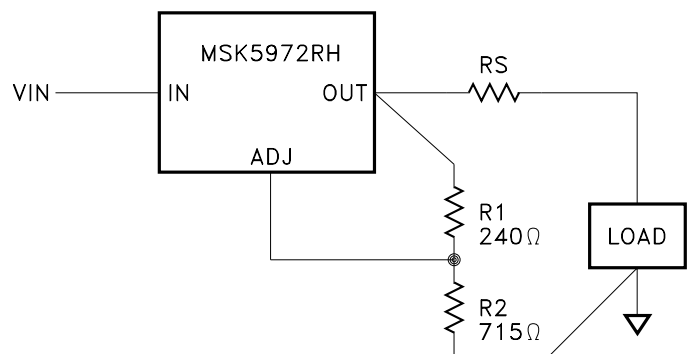

FIGURE 2B
(Best Case Regulation)

INPUT VOLTAGE

The MSK5972RH can operate over a wide input voltage range. VIN minimum = VOUT + dropout to a (VIN - VOUT) maximum of 40V. When operating near the minimum input voltage level sufficient overhead must be maintained to eliminate the regulator from dropping out of regulation, reference the dropout curves in the typical performance section. The input level also effects the maximum current that the MSK5972RH can supply, this too can be found in the typical performance section. Dropout, output current and power dissipation must all be considered when selecting the input line level.

PROTECTION DIODES

When external capacitors are used with any IC regulator it is sometimes necessary to add protection diodes to prevent the capacitors from discharging through low current points into the regulator. Most 10µF capacitors have low enough internal series resistance to deliver 20A spikes when shorted. Although the surge is short, there is enough energy to stress MSK5972RH. When an output capacitor is connected to a regulator and the input is shorted or crowbarred, the output capacitor will discharge into the output of the regulator. The discharge current depends on the value of the capacitor, the output voltage of the regulator, and the rate of decrease of VIN. Figure 3 shows an MSK5972RH with protection diodes included. D2 is only required if the adjust pin has external capacitance tied to it .

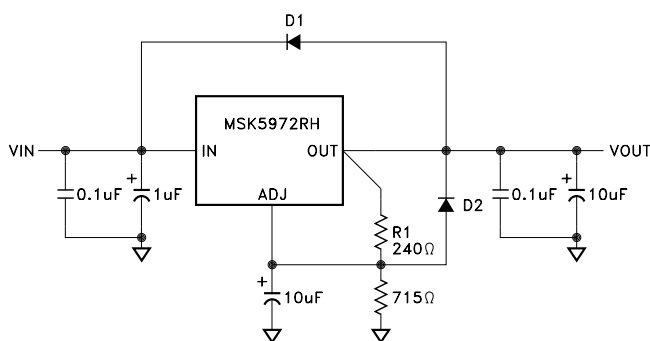

TYPICAL APPLICATION

FIGURE 3

HEAT SINKING

To determine if a heat sink is required for your application and if so, what type, refer to the thermal model and governing equation below.

$$\text{Governing Equation: } T_j = P_d \times (R_{\theta jc} + R_{\theta cs} + R_{\theta sa}) + T_a$$

WHERE

- T_j = Junction Temperature
- P_d = Total Power Dissipation
- R_{θjc} = Junction to Case Thermal Resistance
- R_{θcs} = Case to Heat Sink Thermal Resistance
- R_{θsa} = Heat Sink to Ambient Thermal Resistance
- T_c = Case Temperature
- T_a = Ambient Temperature
- T_s = Heat Sink Temperature

EXAMPLE:

This example demonstrates an analysis on a 10V regulator where the output current is at 0.5 amp and the input is 15V.

Conditions for MSK5972RH:

$$V_{IN} = +15V; I_{out} = 0.5A$$

- 1.) Assume 45° heat spreading model.
- 2.) Find regulator power dissipation:

$$\begin{aligned} P_d &= (V_{IN} - V_{OUT})(I_{out}) \\ P_d &= (15V - 10V)(0.5A) \\ P_d &= 2.5W \end{aligned}$$

- 3.) For conservative design, set T_j = +125°C Max.
- 4.) For this example, worst case T_a = +90°C.
- 5.) R_{θjc} = 4.5°C/W from the Electrical Specification Table.
- 6.) R_{θcs} = 0.15°C/W for most thermal greases.
- 7.) Rearrange governing equation to solve for R_{θsa}:

$$\begin{aligned} R_{\theta sa} &= ((T_j - T_a)/P_d) - (R_{\theta jc}) - (R_{\theta cs}) \\ &= (125^\circ\text{C} - 90^\circ\text{C})/2.5W - 4.5^\circ\text{C}/W - 0.15^\circ\text{C}/W \\ &= 9.3^\circ\text{C}/W \end{aligned}$$

In this case the result is 9.3°C/W. Therefore, a heat sink with a thermal resistance of no more than 9.3°C/W must be used in this application to maintain regulator circuit junction temperature under 125°C.

TOTAL DOSE RADIATION TEST PERFORMANCE

Radiation performance curves for TID testing have been generated for all radiation testing performed by TTM Technologies. These curves show performance trends throughout the TID test process and are located in the MSK5972RH radiation test report. The complete radiation test report is available in the RAD HARD PRODUCTS section on the TTM Technologies website.

TYPICAL PERFORMANCE CURVES

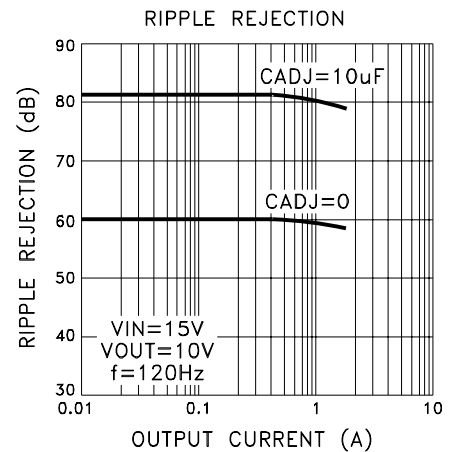
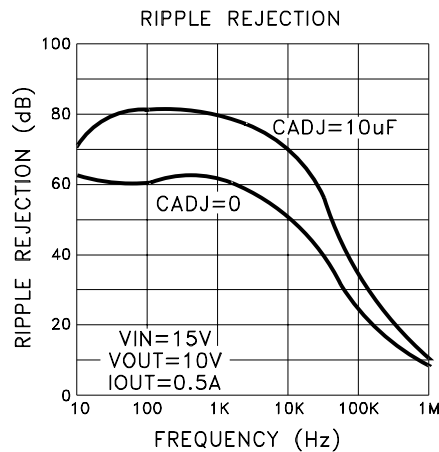
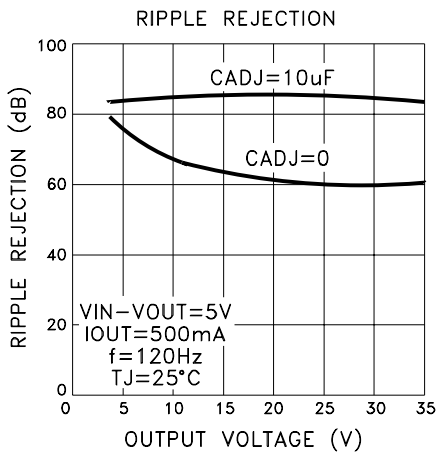
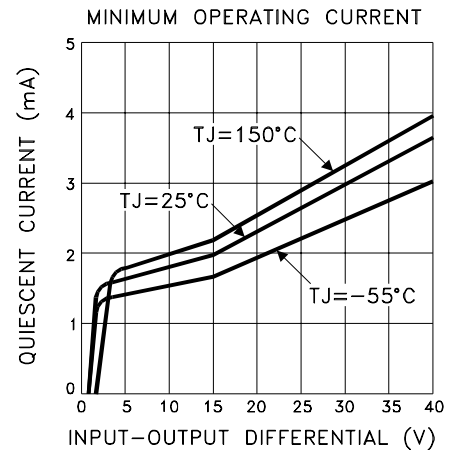
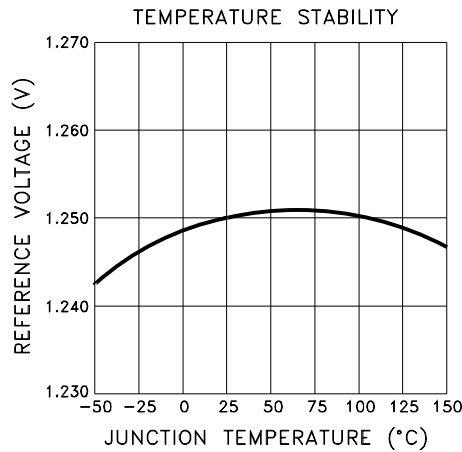
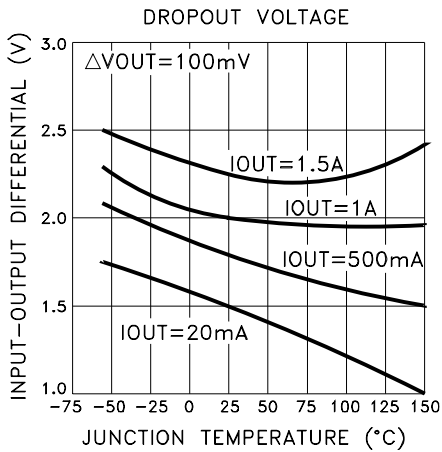
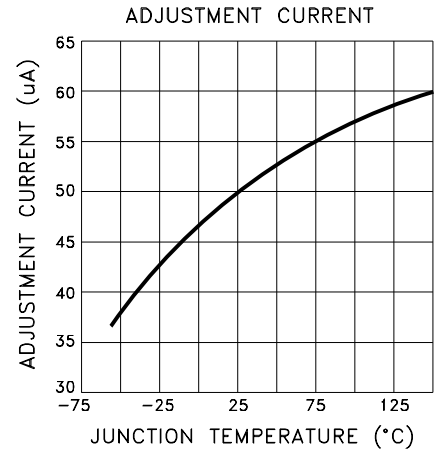
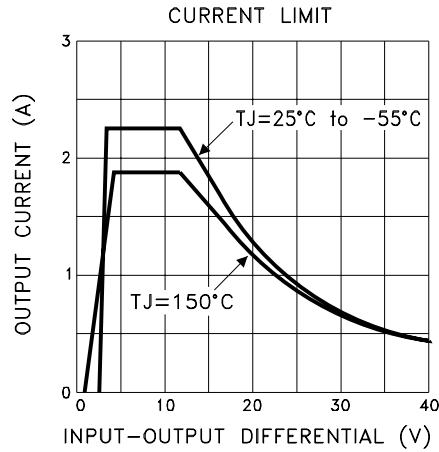
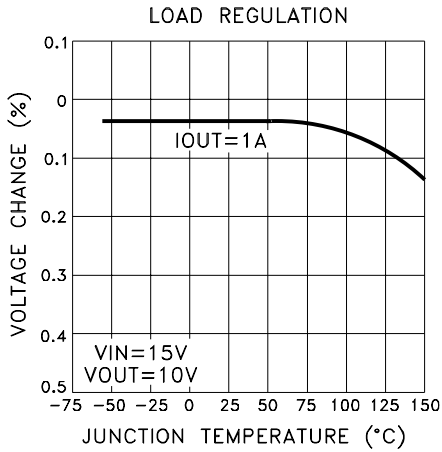

MECHANICAL SPECIFICATIONS

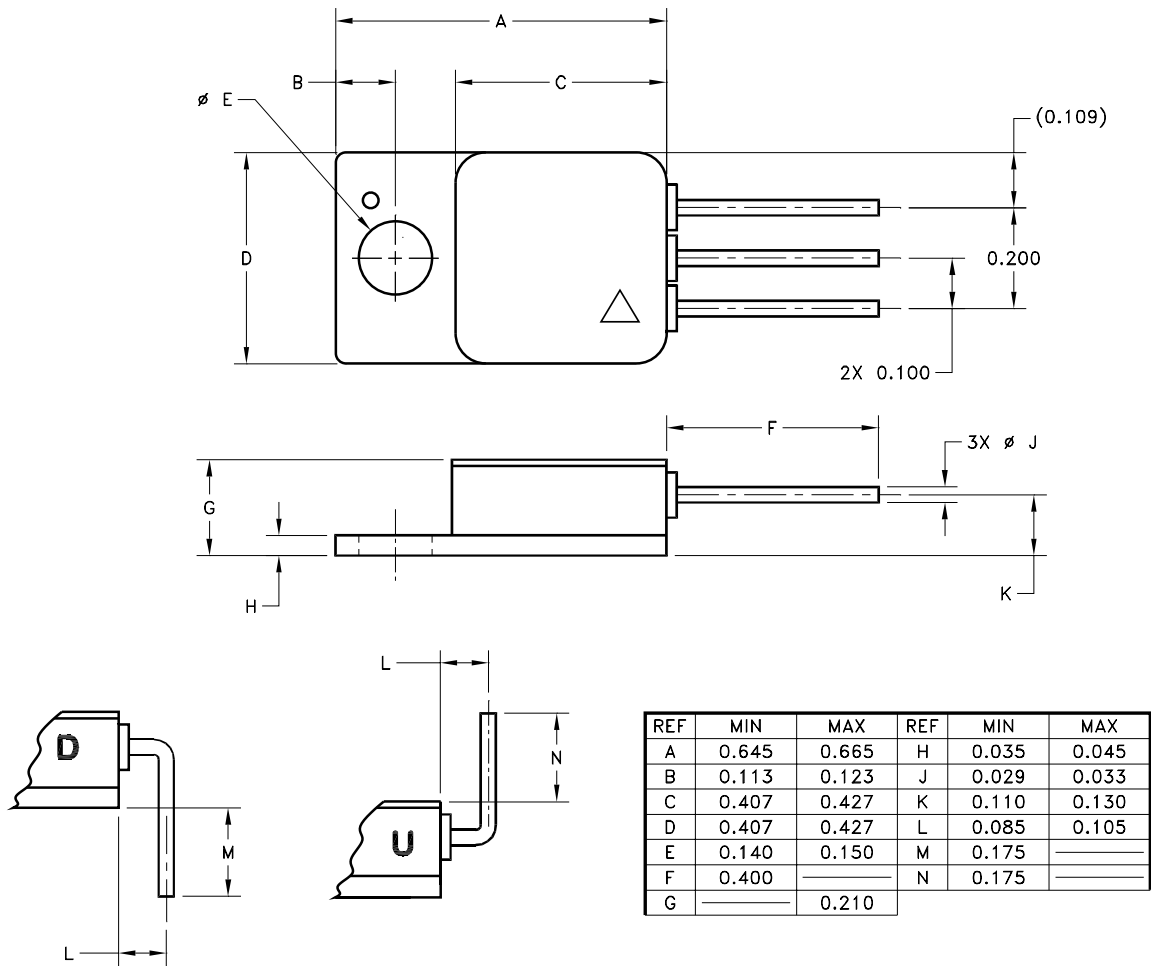

ESD TRIANGLE INDICATES PIN 1
WEIGHT = 3.2 GRAMS TYPICAL

ALL DIMENSIONS ARE SPECIFIED IN INCHES

ORDERING INFORMATION

MSK5972 K RH U

LEAD CONFIGURATIONS

S = STRAIGHT; U = BENT UP; D = BENT DOWN

RADIATION HARDENED

SCREENING

BLANK = INDUSTRIAL; H = MIL-PRF-38534 CLASS H;

K = MIL-PRF-38534 CLASS K

GENERAL PART NUMBER

The above example is an adjustable Class K regulator with leads bent up.
Ordering information for the 3 pad ceramic SMD-1 package is contained on the next page.

NOTE: See DLA SMD 5962R09213 for DLA part number options.

MECHANICAL SPECIFICATIONS

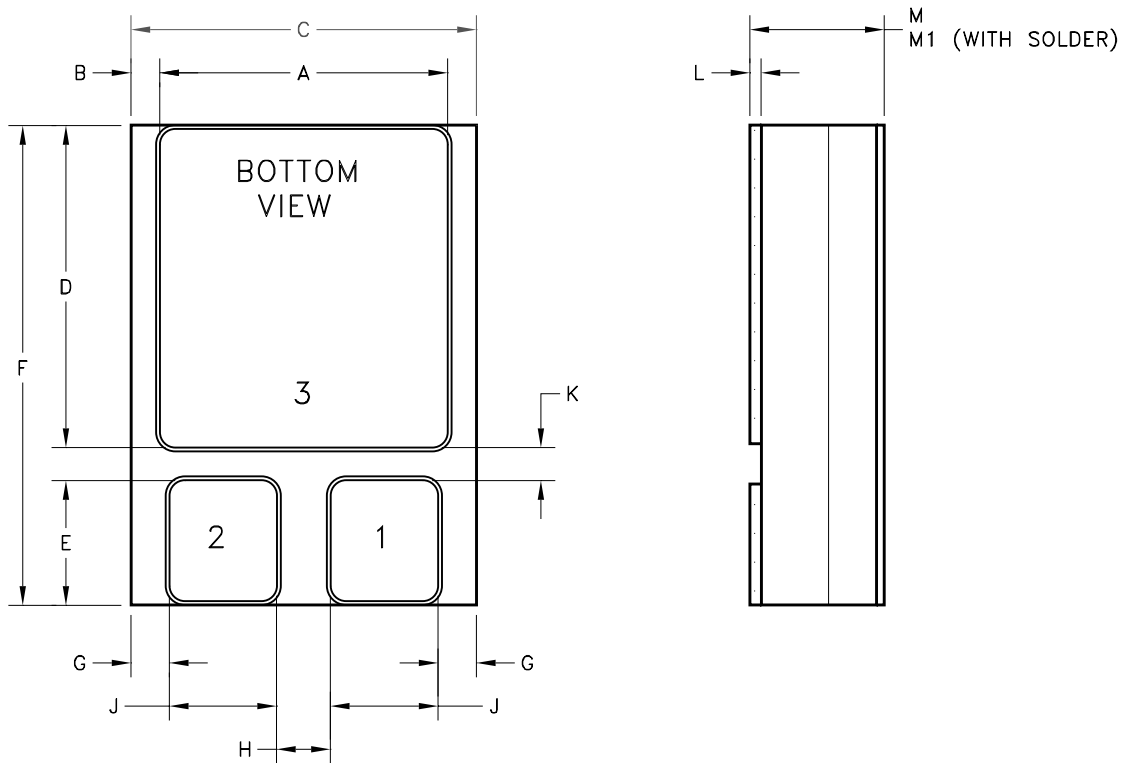

REF	MIN	MAX	REF	MIN	MAX
A	0.365	0.385	H	0.035	—
B	0.032	0.042	J	0.130	0.150
C	0.440	0.460	K	0.030	—
D	0.405	0.425	L	0.012	0.018
E	0.152	0.162	M	—	0.130
F	0.615	0.635	M1	—	0.135
G	0.045	0.055			

WEIGHT = 2.2 GRAMS TYPICAL

ALL DIMENSIONS ARE SPECIFIED IN INCHES

ORDERING INFORMATION

MSK5972 K RH L

3 PAD CERAMIC SMD-1 PACKAGE
RADIATION HARDENED
SCREENING

BLANK = INDUSTRIAL; H = MIL-PRF-38534 CLASS H;
K = MIL-PRF-38534 CLASS K

GENERAL PART NUMBER

The above example is an adjustable Class K regulator.

NOTE: See DLA SMD 5962R09213 for DLA part number options.

REVISION HISTORY

REV	STATUS	DATE	DESCRIPTION
G	Released	09/14	Format update, add internal note and clarify mechanical specifications
H	Released	07/18	Update mechanical outline to show ceramic seals
J	Released	04/22	Remove MIL-PRF-38535, update company name and website

TTM Technologies
www.ttmtech.com

The information contained herein is believed to be accurate at the time of printing. TTM Technologies reserves the right to make changes to its products or specifications without notice, however and assumes no liability for the use of its products. Please visit our website for the most recent revision of this data sheet.