



**RAD HARD POSITIVE,
2.8A, SINGLE RESISTOR
ADJ VOLTAGE REGULATOR**

5986RH

FEATURES:

- Manufactured using  Space Qualified RH3083 Die
- MIL-PRF-38534 Class K Processing & Screening
- Total Dose Hardened to 100 Krads(Si) (Method 1019.7 Condition A)
- Total Dose tested to 450 Krads(Si) (Method 1019.7 Condition A)
- Output Adjustable to Zero Volts
- Internal Short Circuit Current Limit
- Output Voltage is Adjustable with 1 External Resistor
- Output Current Capability to 2.8A
- Internal Thermal Overload Protection
- Outputs may be Paralleled for Higher Current
- Contact TTM Technologies for MIL-PRF-38534 Qualification Status

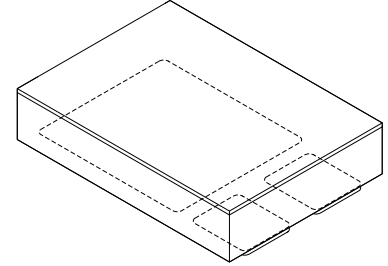

DESCRIPTION:

The MSK5986RH offers an output voltage range down to zero volts while offering radiation tolerance for space applications. This, combined with the low θ_{JC} , allows increased output current while providing exceptional device efficiency. Output voltage is selected by the user through the use of 1 external resistor. Additionally, the regulator offers internal short circuit current and thermal limiting, which allows circuit protection and eliminates the need for external components and excessive derating. The MSK5986RH is hermetically sealed in a space efficient 3 pin power surface mount ceramic package.

EQUIVALENT SCHEMATIC

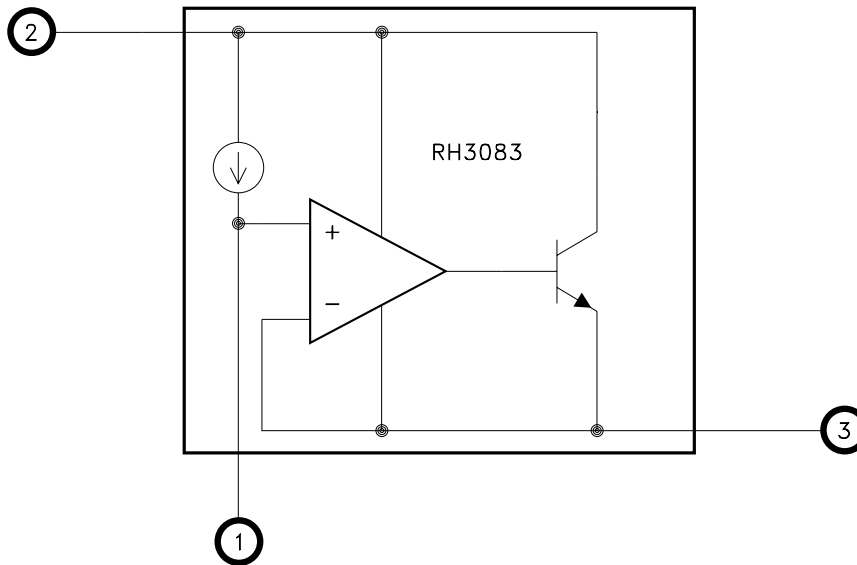

TYPICAL APPLICATIONS

- High Efficiency Linear Regulators
- Constant Voltage/Current Regulators
- Space System Power Supplies
- Switching Power Supply Post Regulators
- Very low Voltage Power Supplies

PIN-OUT INFORMATION

- 1 SET
 - 2 VIN
 - 3 VOUT
- LID = ISOLATED

 and the Linear Technology logo are registered trademarks and RH3083 is a copyright of Linear Technology Corporation

ABSOLUTE MAXIMUM RATINGS ^⑩

| | | | | | |
|------|--------------------------------------|-------------|-----|---|--------------------|
| VIN | Input Voltage... ^⑦ | +18V, -0.3V | Pd | Power Dissipation..... | Internally Limited |
| | No Overload or Short... ^⑦ | +23V,-0.3V | TJ | Junction Temperature..... | +150°C |
| IOUT | Output Current..... | 3.0A | TST | Storage Temperature Range..... | -65°C to +150°C |
| ISET | Set Pin Current... ^⑧ | ±25mA | TLD | Lead Temperature Range (10 Seconds)..... | 300°C |
| VSET | Set Pin Voltage... ^⑦ | ±10V | Tc | Case Operating Temperature | |
| | | | | MSK5986RH..... | -40°C to +85°C |
| | | | | MSK5986K/H RH..... | -55°C to +125°C |
| | | | | ESD Rating..... | CLASS 2 |

ELECTRICAL SPECIFICATIONS

| Parameter | Test Conditions ^{① ⑪} | Group A Subgroup | MSK 5986K/H RH | | | MSK 5986RH | | | Units | |
|-----------------------------------|--|------------------|----------------|-------|------|------------|-------|------|-------|-------|
| | | | Min. | Typ. | Max. | Min. | Typ. | Max. | | |
| Set Pin Current (ISET) | VIN = 3.0V VOUT = 1.0V 5mA ≤ ILOAD ≤ 2.8A | 1 | 49.5 | 50 | 50.5 | 49.5 | 50 | 50.5 | uA | |
| | | 2, 3 | 49 | - | 51.5 | - | - | - | uA | |
| | | Post Radiation | 1 | 49 | - | 51 | 49 | - | 51 | uA |
| Output Offset Voltage (VOS) | VIN = 3.0V VOUT = 1.0V ILOAD = 5mA | 1 | -4.5 | 0 | 4.5 | -4.5 | 0 | 4.5 | mV | |
| | | 2, 3 | -6 | - | 6 | - | - | - | mV | |
| Load Regulation | VIN = 3.0V VOUT = 0V 5mA ≤ ILOAD ≤ 2.8A | (ΔVOS) | 1, 2, 3 | -4 | - | 4 | -4 | - | 4 | mV |
| | | (ΔISET) | 1, 2, 3 | -300 | -10 | +300 | -300 | -10 | +300 | nA |
| Line Regulation | ΔVIN = 3V TO 24V VOUT = 0V ILOAD = 5mA | (ΔVOS) | 1, 2, 3 | -0.05 | - | 0.05 | -0.05 | - | 0.05 | mV/V |
| | | (ΔISET) | 1, 2, 3 | -10 | 0.1 | +10 | -10 | 0.1 | +10 | nA/V |
| Dropout Voltage ^② | VOUT = 1.0V ILOAD = 2.8A | 1% ΔVOUT | 1 | - | 1.47 | - | - | 1.47 | - | V |
| | | 10% ΔVOUT | 1 | - | 1.94 | - | - | 1.94 | - | V |
| Current Limit ^⑨ | VIN = 5.0V VOUT = 1.0V | 1 | 2.8 | 3.4 | - | 2.8 | 3.4 | - | A | |
| | | 2, 3 | 2.8 | - | - | - | - | - | A | |
| Minimum Load Current ^⑥ | VIN = 23V | - | - | - | 1 | - | - | 1 | mA | |
| Ripple Rejection ^② | F = 120Hz ΔVIN = 0.5Vpp | - | - | 85 | - | - | 85 | - | dB | |
| Output Noise ^② | VIN = 3V RLOAD = 2.5Ω 10Hz to 100KHz | CSET = 0.1uF | - | - | 40 | - | - | 40 | - | uVRMS |
| Thermal Resistance ^② | Junction to Case @ 125°C | - | - | 1.5 | 1.9 | - | 1.5 | 1.9 | °C/W | |

NOTES:

- ① Output is decoupled to ground using a 220μF tantalum low ESR capacitor in parallel with 3 pieces of 1.0μF and one 0.1μF ceramic capacitor unless otherwise specified. (See Figure 1)
- ② Guaranteed by design but not tested. Typical parameters are representative of actual device performance but are for reference only.
- ③ Industrial grade devices shall be tested to subgroup 1 unless otherwise specified.
- ④ Class H and K devices shall be 100% tested to subgroups 1, 2 and 3.
- ⑤ Subgroup

| | |
|---|------------------|
| 1 | TA = TC = +25°C |
| 2 | TA = TC = +125°C |
| 3 | TA = TC = -55°C |
- ⑥ Minimum load current verified while testing line regulation.
- ⑦ Voltage is measured with respect to VOUT.
- ⑧ Set pin is clamped to VOUT with diodes in series with 1KΩ resistors. Current will flow under transient conditions.
- ⑨ Reference current limit typical performance curve for output current capability versus voltage drop.
- ⑩ Continuous operation at or above absolute maximum ratings may adversely effect the device performance and/or life cycle.
- ⑪ Pre and Post irradiation limits at 25°C, up to 100 Krad(Si) TID, are identical unless otherwise specified.

APPLICATION NOTES

OUTPUT VOLTAGE

A single resistor (RSET) from the SET pin to ground creates the reference voltage for the internal Error Amplifier. The MSK5986RH SET pin supplies a constant current of 50uA that develops the reference voltage. The output voltage is simply $RSET \times 50\mu A$. Since the output is internally driven by a unity-gain amplifier, an alternative to using RSET is to connect a high quality reference source to the SET pin. With a minimum load requirement of 1mA on the Output, the Output Voltage can be adjusted to near 0V. To bring the output voltage to 0V, the load must be connected to a slightly negative voltage supply to sink the 1mA minimum load current from a 0V output.

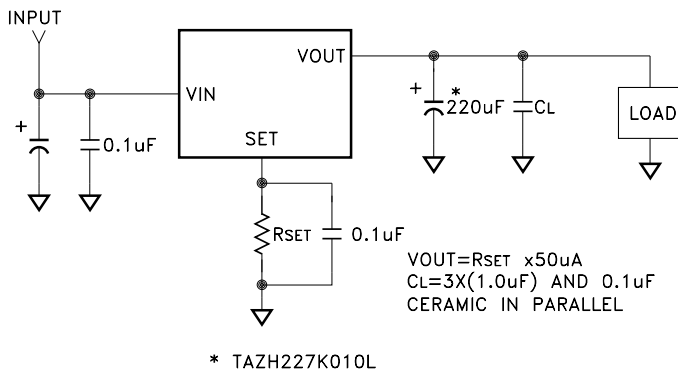

FIGURE 1

INPUT CAPACITANCE

Pin 1 is the connection to the collector of the power device and the control circuitry of the MSK5986RH. Output load current is supplied through these pins. Minimum input capacitance for these devices is 10uF. Low ESR, ceramic input capacitors are acceptable for applications without long input leads. For applications with long input leads, the self inductance of the wires can cause instability. Care must be taken to minimize the inductance of the input wires. This can be accomplished through the use of series resistance or higher ESR input capacitors. A minimum of 10uF of low ESR tantalum bulk capacitance in parallel with low value ceramic decoupling capacitance is recommended.

VIN

The VIN pin supplies power to the control circuitry and the collector of the output pass transistor. Control circuitry requirements determine the minimum input voltage for the device. For proper operation VIN should be a minimum of 1.55V greater than VOUT. Reference the dropout curve for more information.

OUTPUT CAPACITANCE

For stability purposes, the MSK5986RH requires a minimum output capacitor of 10uF with an ESR of 0.5Ω or less. Tantalum or ceramic capacitors are recommended. A larger capacitance value will improve transient response for increased load current changes. Consideration must also be given to temperature characteristics of the capacitors used.

ADDITIONAL STABILITY

A capacitor placed in parallel with the SET pin resistor to ground, will improve the output transient response and filter noise in the system. To reduce output noise, typically 500-1000pF is required. Capacitors up to 1μF can be used, however consideration must be given to the effect the time constant created will have on the startup time.

LOAD REGULATION

The MSK5986RH specified load regulation is Kelvin Sensed, therefore the parasitic resistance of the system must be considered to design an acceptable load regulation. The overall load regulation includes the specified MSK5986RH load regulation plus the parasitic resistance multiplied by the load current as shown in Figure 2. RSO is the series resistance of all conductors between the MSK5986RH output and the load. It will directly increase output load regulation error by a voltage drop of $\Delta IO \times RSO$. RSS is the series resistance between the SET pin and the load. RSS will have little effect on load regulation if the SET pin trace is connected as close to the load as possible keeping the load return current on a separate trace as shown. RSR is the series resistance of all of the conductors between the load and the input power source return. RSR will not effect load regulation if the SET pin is connected with a Kelvin Sense type connection as shown in Figure 3, but it will increase the effective dropout voltage by a factor of $IO \times RSR$. Keeping RSO and RSR as low as possible will ensure minimal voltage drops and wasted power.

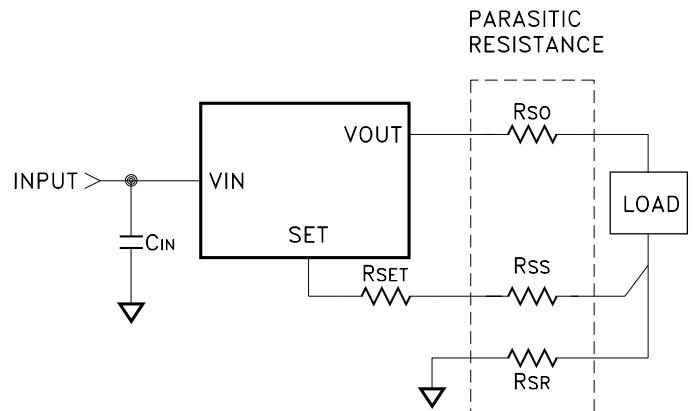

FIGURE 2

PARALLELING DEVICES

When currents greater than 2.8A are needed, the MSK5986RH's may be paralleled to multiply the current capacity. As shown in Figure 3, the VIN and SET pins must be tied together. The VOUT pins are connected to the load with consideration to the conductor resistance. The conductor resistance of each MSK5986RH VOUT connection to the load, must be equal to create equal load sharing. As little as 10mΩ ballast resistance typically ensures better than 80% equal sharing of load current at full load. Additional consideration must be given to the effect the additional VOUT conductor resistance has on load regulation; see paragraph titled "Load Regulation".

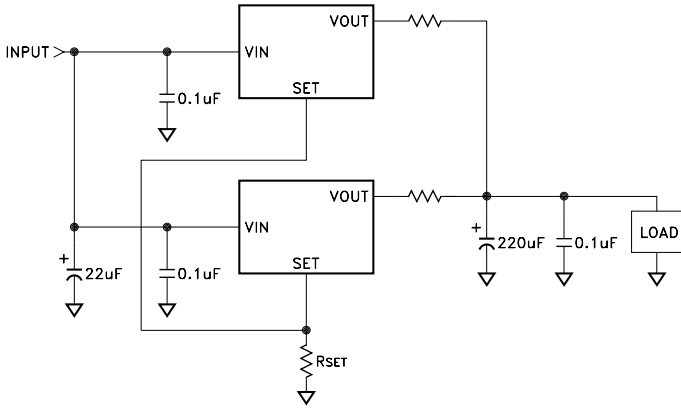

FIGURE 3

IMPROVING INITIAL ACCURACY AND REDUCING TEMPERATURE DRIFT

The initial output accuracy of the MSK5986RH due to SET pin current tolerance and set point resistor accuracy can be reduced to 0.2% using the MSK109RH radiation hardened precision reference. Minimal drift of the MSK109RH from temperature extremes and irradiation ensure very tight regulation. The circuit can be configured to use the 2.5V reference to directly set the output at 2.5V or with a slight variation it can provide any output within the operating range of the MSK5986RH down to 0V output. Select RS to maintain between 1mA and 10mA of current through the reference; see Figure 4 below. RS may be tied to VIN or another power source. The optional trim resistor can be used to further trim out initial output and system error. Reference the MSK109RH data sheet for application circuits that provide stable output voltages across the full operating range of the MSK5986RH including down to 0V output and the operating characteristics of the MSK109RH.

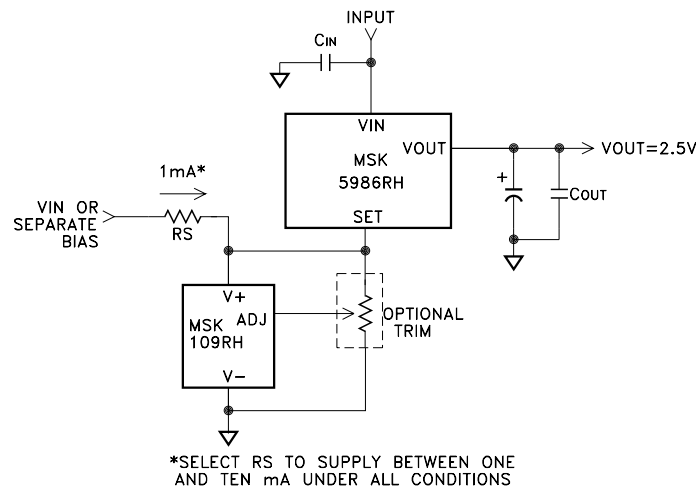

FIGURE 4

ADDING SHUTDOWN

The MSK5986RH can be easily shutdown by either reducing RSET to 0Ω or connecting a transistor from the SET pin to ground. By connecting two transistors, as shown in Figure 5, a low current voltage source is all that is required to take the SET pin to ground as well as pull the output voltage to ground. Q2 pulls the output voltage to ground when no load is present and only needs to sink 10mA.

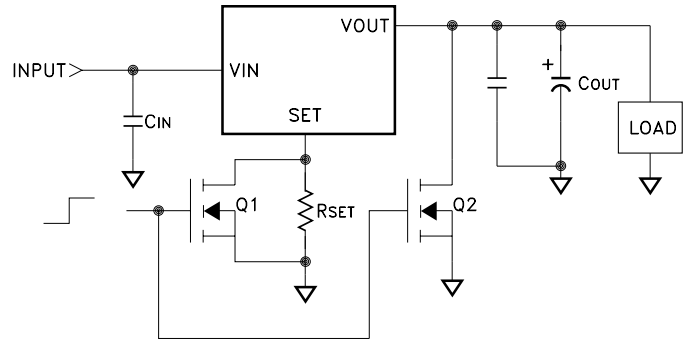

FIGURE 5

APPLICATION NOTES CONT'D

HEAT SINKING

To determine if a heat sink is required for your application and if so, what type, refer to the thermal model and governing equation below.

Governing Equation: $T_J = P_D \times (R_{\theta_{JC}} + R_{\theta_{CS}} + R_{\theta_{SA}}) + T_A$

WHERE

T_J = Junction Temperature

P_D = Total Power Dissipation

$R_{\theta_{JC}}$ = Junction to Case Thermal Resistance

$R_{\theta_{CS}}$ = Case to Heat Sink Thermal Resistance

$R_{\theta_{SA}}$ = Heat Sink to Ambient Thermal Resistance

T_C = Case Temperature

T_A = Ambient Temperature

T_S = Heat Sink Temperature

EXAMPLE:

This example demonstrates the thermal calculations for the regulator operating at 1.5A output current.

Conditions for MSK5986RH:

$V_{IN} = +3.0V$; $I_{OUT} = +1.5A$ $V_{OUT} = +1.0V$

- 1.) Assume 45° heat spreading model.
- 2.) Find regulator power dissipation:

$$\begin{aligned} P_D &= (V_{IN} - V_{OUT}) (I_{OUT}) \\ P_D &= (3-1) (1.50) \\ &= 3.0W \end{aligned}$$

- 3.) For conservative design, set $T_J = +125^\circ\text{C}$ Max.
- 4.) For this example, worst case $T_A = +90^\circ\text{C}$.
- 5.) $R_{\theta_{JC}} = 1.9^\circ\text{C/W}$ from the Electrical Specification Table.
- 6.) $R_{\theta_{CS}} = 0.15^\circ\text{C/W}$ for most thermal greases.
- 7.) Rearrange governing equation to solve for $R_{\theta_{SA}}$:

$$\begin{aligned} R_{\theta_{SA}} &= (T_J - T_A)/P_D - (R_{\theta_{JC}}) - (R_{\theta_{CS}}) \\ &= (125^\circ\text{C} - 90^\circ\text{C})/3.0W - 1.9^\circ\text{C/W} - 0.15^\circ\text{C/W} \\ &= 9.6^\circ\text{C/W} \end{aligned}$$

In this case the result is 9.6°C/W. Therefore, a heat sink with a thermal resistance of no more than 9.6°C/W must be used in this application to maintain regulator circuit junction temperature under 125°C.

TOTAL DOSE RADIATION TEST PERFORMANCE

Radiation performance curves for TID testing have been generated for all radiation testing performed by TTM Technologies. These curves show performance trends throughout the TID test process and can be located in the MSK5986RH radiation test report. The complete radiation test report will be available in the RAD HARD PRODUCTS section on the TTM Technologies website.

ADDITIONAL APPLICATION INFORMATION

For additional applications information, please reference Linear Technology Corporation's® LT3083 and RH3083 data sheets.

TYPICAL PERFORMANCE CURVES

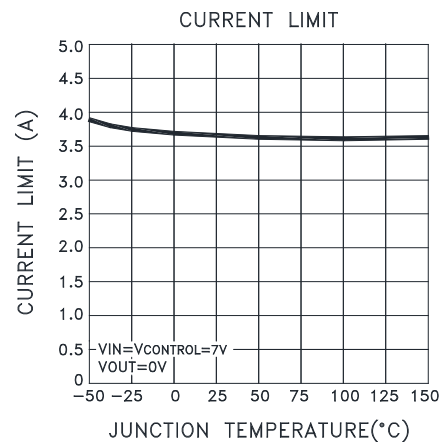
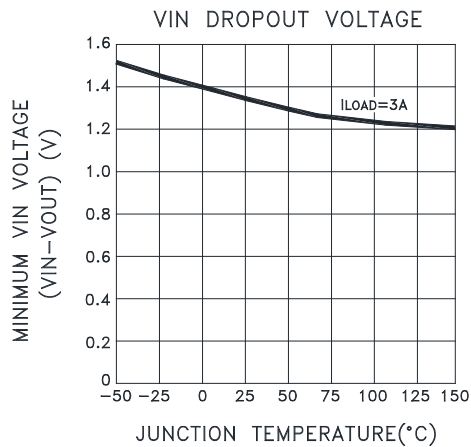
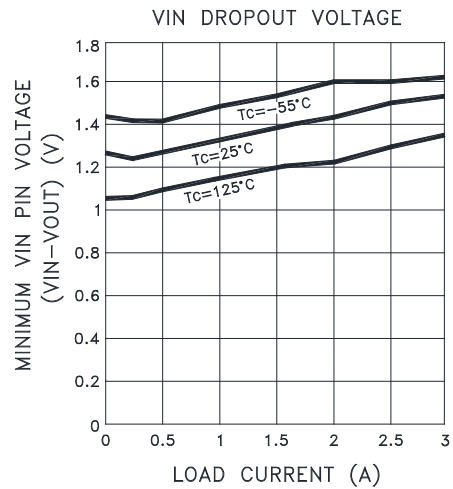
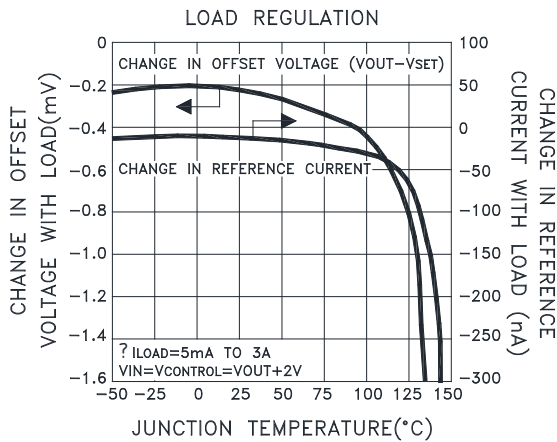
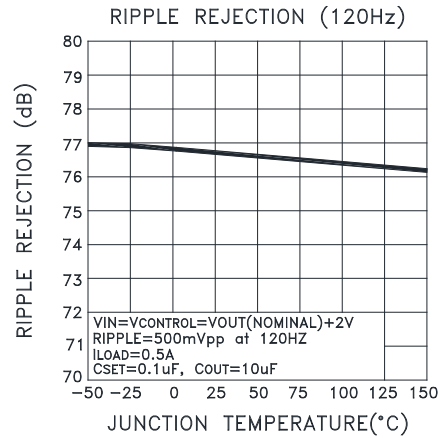
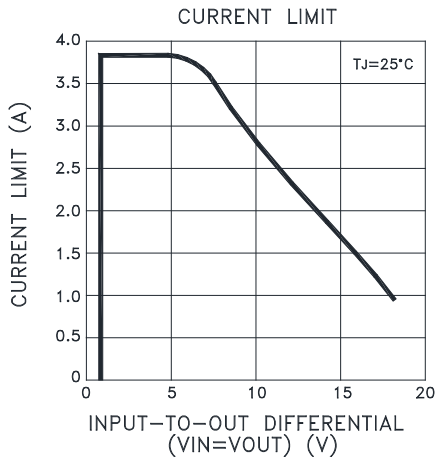
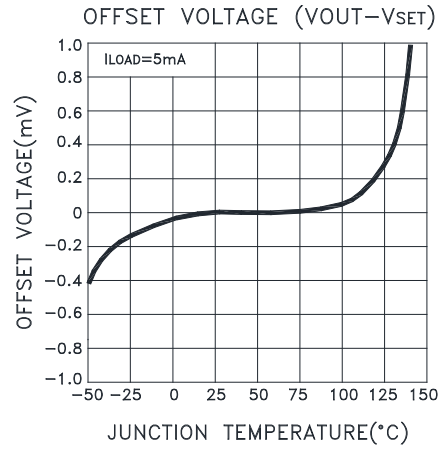
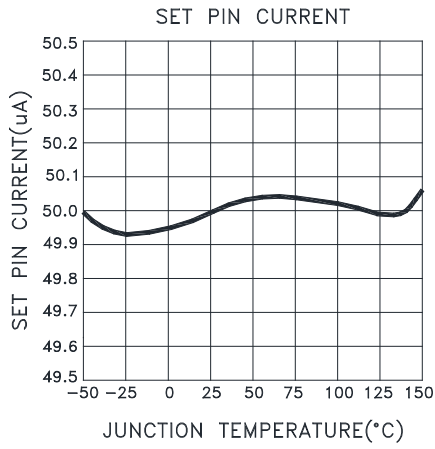

MECHANICAL SPECIFICATIONS

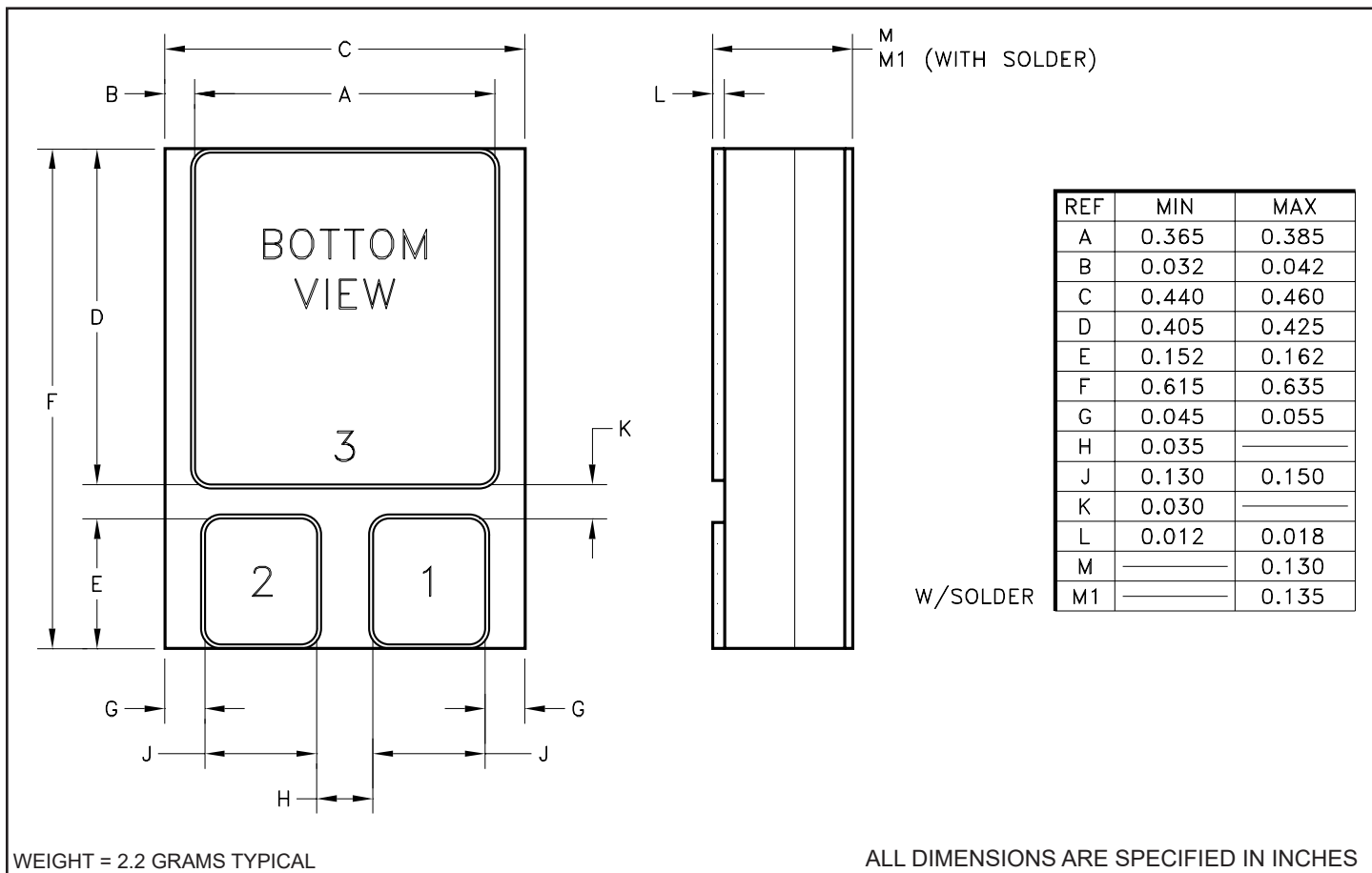

ORDERING INFORMATION

MSK5986 K RH

RADIATION HARDENED
SCREENING

BLANK = INDUSTRIAL

K = MIL-PRF-38534 CLASS K;

H = MIL-PRF-38534 CLASS H

GENERAL PART NUMBER

The above example is a Class K regulator.

REVISION HISTORY

| REV | STATUS | DATE | DESCRIPTION |
|-----|-------------|-------|--|
| - | Preliminary | 01/14 | Initial Release |
| A | Preliminary | 01/14 | Add clarifications for block diagram, electrical specifications, max ratings and applications section. |
| B | Preliminary | 03/14 | Add clarifications. |
| C | Preliminary | 04/14 | Correct pin designations. |
| D | Preliminary | 09/14 | Update electrical specifications. |
| E | Preliminary | 12/17 | Add ESD Rating |
| F | Released | 02/18 | Update radiation status |
| G | Released | 04/22 | Remove MIL-PRF-38535, update company name and website |

TTM Technologies
www.ttmtech.com

The information contained herein is believed to be accurate at the time of printing. TTM Technologies reserves the right to make changes to its products or specifications without notice, however and assumes no liability for the use of its products. Please visit our website for the most recent revision of this data sheet.