

## **MSK4361/4362 Evaluation Board User's Guide**

By Bob Abel & Dan Williams, MS Kennedy Corp.; Revised 9/19/2013

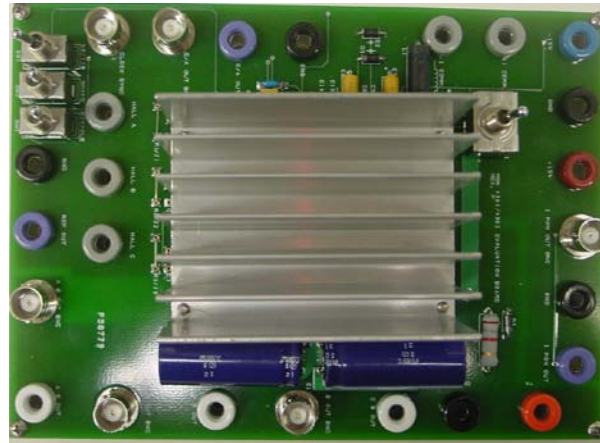

### **Introduction**

The MSK4361 is a complete 3 Phase MOSFET Bridge Brushless Motor Control System in a convenient isolated hermetic package. The hybrid is capable of 30 amps of output current and 75 volts of DC bus voltage. It has the normal features for protecting the bridge. Included is all the bridge drive circuitry, hall sensing circuitry, commutation circuitry and all the current sensing and analog circuitry necessary for closed loop current mode (torque) control. When PWM'ing, the transistors are modulated in locked anti-phase mode for the tightest control and the most bandwidth. Provisions for applying different compensation schemes are included. The MSK4361 has good thermal conductivity of the MOSFET's due to isolated package design that allows direct heat sinking of the hybrid without insulators. The MSK4362 has +/-15V regulators integrated into the package to run the low power section of the hybrid, and/or for other external uses. See data sheet for regulator power dissipation calculation assistance.

The evaluation board provides a platform from which to evaluate new designs with ample real estate to make changes and evaluate results. Evaluation early in the design phase reduces the likelihood instability, or other issues, from becoming a problem at the application PCB level.

This application note is intended to be used in conjunction with the MSK4361 and MSK4362 data sheets, so please reference the data sheet for additional application information and specifications.

## Setup

Use the standard 4mm banana jacks to interface with the assembly to connect to your power supply and motor assembly. The BNC connectors are provided to monitor the phase signals, clock sinc, E/A Mon., and I Mon. signals if desired.

## MSK4361/4362 Evaluation Board Schematic

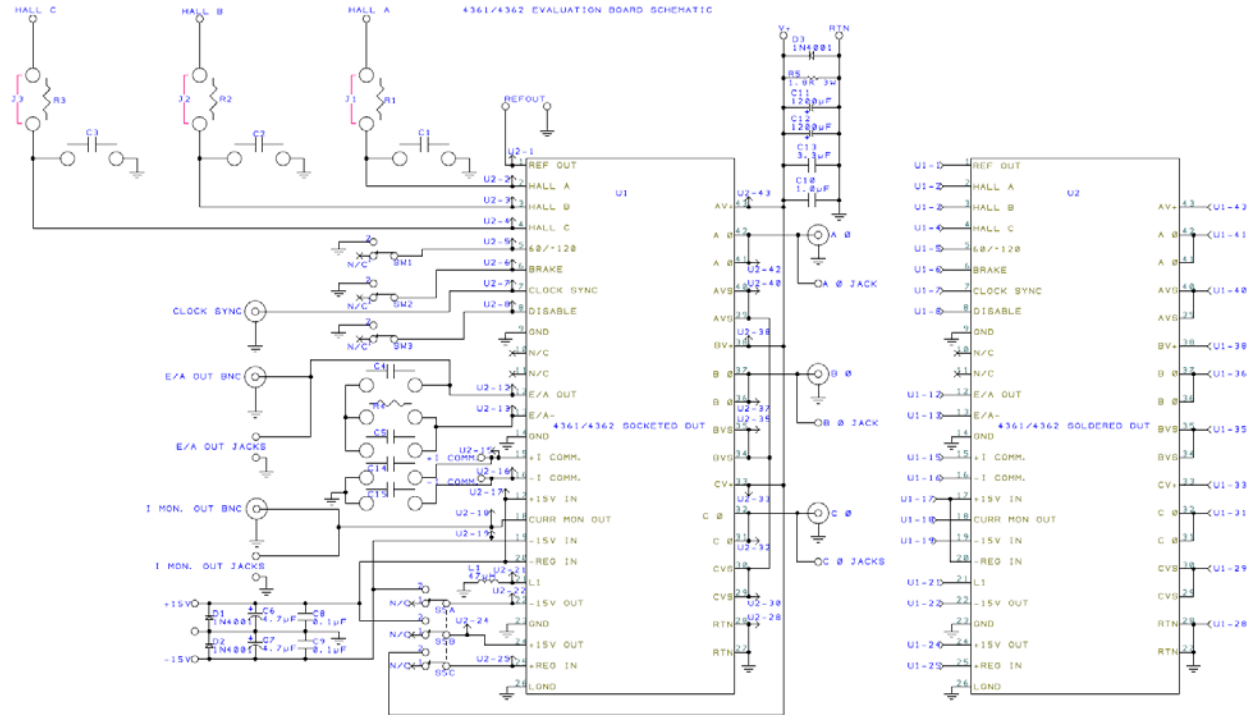

## PCB Artwork

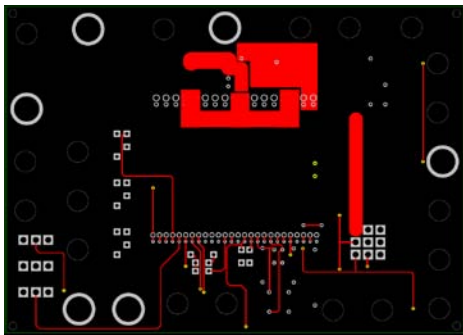

Top Side

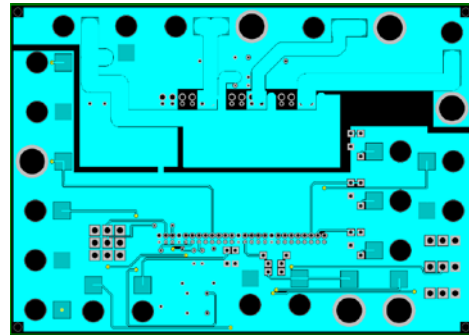

Bottom Side

## Bill of Materials

Ref Desig./Qty.	Description	Manufacturer	Part Number
R1-R4	OPTIONAL	N/A	N/A
L1	47 $\mu$ H	DELEVAN	3474-21L
R5	1.8K, 3W	TBD	TBD
S1, S2, S3	SPDT	NKK	M2012SS1W01
S4	3PDT	NKK	M2032SS1W01
C1-C5, C14, C15	OPTIONAL	N/A	N/A
C6, C7	4.7 $\mu$ F	KEMET	T322D475K050AT
C8, C9	0.1 $\mu$ F	AVX	CK05BX104K
C13	6.8 $\mu$ F, 100V	ILLINOIS CAPACITOR	685MWR100K
C11, C12	1200 $\mu$ F, 63V ELXZ630ELL122ML40S	United Chemi-Con	
C10	1 $\mu$ F, 250V	Panasonic Electronics	ECQ-E2105K
D1, D2, D3	1N4001	1N4001	
19	BANANA JACKS	EMERSON/JOHNSON	108-09XX-001
6	BNC'S	TE Connectivity	1-1337542-0
1	HEATSINK	MSK	2219-15586
48	.015/.025 DIA PIN	MILL MAX	0677-0-15-01-30-27-
10-0			
17	.032/.046 DIA PIN	MILL MAX	0327-0-15-01-34-27-
10-0			
4	7/8", #4, STANDOFFS		
4	3/8", #4, SCREWS		
4	1/2", #4, SCREWS		
1	MSK 4361/4362	MSK	
1	MSK 4361/4362 PCB	ADVANCED CIRCUITS	