



30 AMP, 75V, 3 PHASE MOSFET BRUSHLESS MOTOR CONTROLLER

4362

FEATURES:

- 75 Volt Motor Supply Voltage
- 30 Amp Output Switch Capability
- 100% Duty Cycle High Side Conduction Capable
- Shoot-Through/Cross Conduction Protection
- Hall Sensing and Commutation Circuitry on Board
- "Real" Four Quadrant Torque Control Capability
- Good Accuracy Around the Null Torque Point
- Isolated Package Design for High Voltage Isolation Plus Good Thermal Transfer
- 60°/ 120° Phasing Selectable
- Plus and Minus 15 Volt Regulated Voltage Outputs are available for Powering Other Circuitry
- Contact TTM for MIL-PRF-38534 Qualification Status

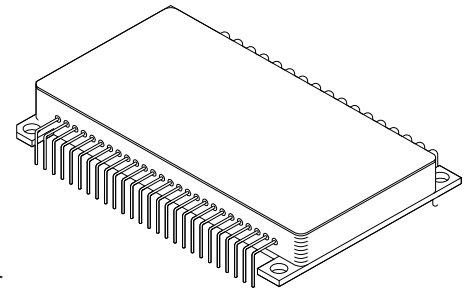

DESCRIPTION:

The MSK4362 is a complete 3 Phase MOSFET Bridge Brushless Motor Control System in a convenient isolated hermetic package. The device is capable of 30 amps of output current and 75 volts of DC bus voltage. It has the normal features for protecting the bridge. Included is all the bridge drive circuitry, hall sensing circuitry, commutation circuitry and all the current sensing and analog circuitry necessary for closed loop current mode (torque) control. When PWM'ing, the transistors are modulated in locked anti-phase mode for the tightest control and the most bandwidth. Provisions for applying different compensation schemes are included. The MSK4362 has good thermal conductivity of the MOSFET's due to isolated package design that allows direct heat sinking of the device without insulators.

EQUIVALENT SCHEMATIC

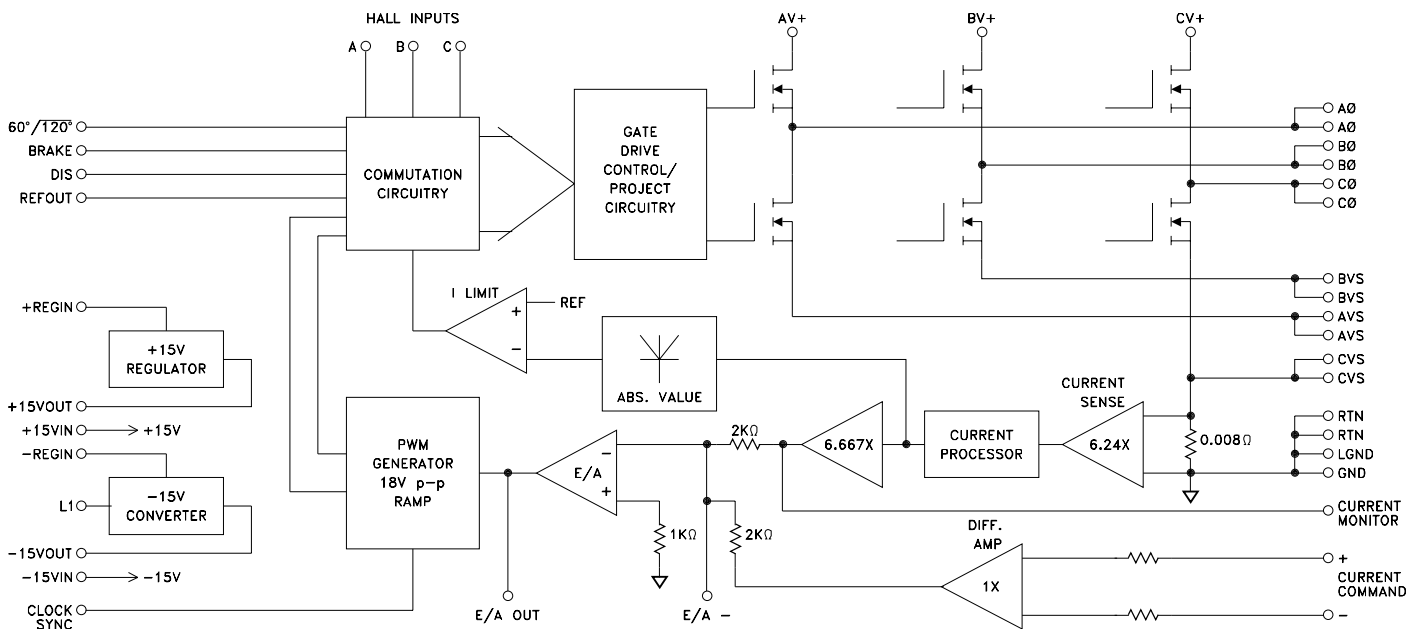

TYPICAL APPLICATIONS

- 3 Phase Brushless DC Motor Control
- Servo Control
- Fin Actuator Control
- Gimbal Control
- AZ-EL Control

PIN-OUT INFORMATION

| | | | |
|----|-----------------------|----|----------|
| 1 | REFOUT | 23 | GND |
| 2 | HALL A | 24 | +15 VOUT |
| 3 | HALL B | 25 | +REG IN |
| 4 | HALL C | 26 | LGND |
| 5 | 60 / $\overline{120}$ | 27 | RTN |
| 6 | BRAKE | 28 | RTN |
| 7 | CLOCK SYNC | 29 | CVS |
| 8 | DIS | 30 | CVS |
| 9 | GND | 31 | CØ |
| 10 | NC | 32 | CØ |
| 11 | NC | 33 | CV+ |
| 12 | E/A OUT | 34 | BVS |
| 13 | E/A - | 35 | BVS |
| 14 | GND | 36 | BØ |
| 15 | +Current Command | 37 | BØ |
| 16 | -Current Command | 38 | BV+ |
| 17 | +15 VIN | 39 | AVS |
| 18 | Current Monitor Out | 40 | AVS |
| 19 | -15 VIN | 41 | AØ |
| 20 | -REG IN | 42 | AØ |
| 21 | L1 | 43 | AV+ |
| 22 | -15 VOUT | | |

ABSOLUTE MAXIMUM RATINGS

⑨

| | |
|---|-----------------|
| High Voltage Supply (Internal regulators disabled) | 75V |
| High Voltage Supply (using internal regulators) (10)..... | 55V |
| Current Command Input..... | ±13.5V |
| Logic Inputs | -0.2V to REFOUT |
| +15VOUT External Load | ±50 mA |
| REFOUT External Load..... | 15 mA |
| E/A OUT External Load | 5 mA |
| Clock SYNC Input..... | -0.2V to +15V |
| Continuous Output Current..... | 30 Amps |
| Peak Output Current..... | 41 Amps |

| | | |
|------|--|-----------------|
| RθJc | Thermal Resistance(Output Switches)..... | 1.5°C/W |
| RθJc | Thermal Resistance (Regulator)..... | 9°C/W |
| TST | Storage Temperature Range ..(11)..... | -65°C to +150°C |
| TLD | Lead Temperature Range (10 Seconds) | +300°C |
| Tc | Case Operating Temperature MSK4362..... | -40°C TO +125°C |
| | MSK4362H | -55°C TO +125°C |
| TJ | Junction Temperature | +150°C |

ELECTRICAL SPECIFICATIONS

| Parameter | Test Conditions | Group A Subgroup | MSK4362H (3) | | | MSK4362 (2) | | | Units |
|--|---|------------------|--------------|------|----------|-------------|------|----------|--------|
| | | | Min. | Typ. | Max. | Min. | Typ. | Max. | |
| INPUT CURRENT | | | | | | | | | |
| +15 VIN | Output PWM'ing Current Command = 0 Volts | 1 | - | 65 | 90 | - | 65 | 90 | mA |
| -15 VIN | | 1 | - | 25 | 40 | - | 25 | 40 | mA |
| PWM | | | | | | | | | |
| Clock Free Running Frequency | | 4 | 21 | 22 | 23 | 20 | 22 | 24 | KHz |
| | | 5, 6 | 18.7 | 22 | 25.3 | - | - | - | KHz |
| CLOCK SYNC INPUT | | | | | | | | | |
| V _{IL} (1) | | - | - | - | 2.5 | - | - | 2.5 | VOLTS |
| V _{IH} (1) | | - | 12.5 | - | - | 12.5 | - | - | VOLTS |
| Duty Cycle (1) | | - | 10 | - | 90 | 10 | - | 90 | % |
| SYNC Frequency (1) | | - | Clock +0 | - | Clock +3 | Clock +0 | - | Clock +3 | KHz |
| REGULATORS VIN = 28V | | | | | | | | | |
| +15 VOUT | 25mA External Load (6) | 1, 2, 3 | 14.25 | - | 15.75 | 14.25 | - | 15.75 | VOLTS |
| -15 VOUT | 25mA External Load (6) | 1, 2, 3 | -14.25 | - | -15.75 | -14.25 | - | -15.75 | VOLTS |
| REFOUT | 15mA External Load | 1, 2, 3 | 5.82 | - | 6.57 | 5.82 | - | 6.57 | VOLTS |
| -15 VOUT Ripple | 25mA External Load (6) | 4 | - | - | 250 | - | - | 250 | mV |
| LOGIC INPUTS | | | | | | | | | |
| (Hall A, B, C, Brake, 60°/120°, DIS) | | | | | | | | | |
| V _{IL} (1) | | - | - | - | 0.8 | - | - | 0.8 | VOLTS |
| V _{IH} (1) | | - | 3.0 | - | - | 3.0 | - | - | VOLTS |
| ANALOG SECTION | | | | | | | | | |
| Current Command Input Range (1) | | - | -13.5 | - | +13.5 | -13.5 | - | +13.5 | VOLTS |
| Current Command Input Current (1) | | - | - | - | 1.5 | - | - | 1.5 | mA |
| Transconductance (8) | | 4 | 2.70 | 3 | 3.30 | 2.55 | 3 | 3.45 | A/V |
| | | 5, 6 | 2.4 | 3 | 3.6 | - | - | - | A/V |
| Offset Current | Current Command = 0 Volts | 1 | -50 | 0 | 50 | -100 | 0 | 100 | mA |
| | | 2, 3 | -100 | 0 | 100 | - | - | - | mA |
| Current Monitor (8) | | 4 | 0.300 | 0.33 | 0.367 | 0.280 | 0.33 | 0.380 | V/A |
| | | 5, 6 | 0.280 | 0.33 | 0.380 | 0.250 | 0.33 | 0.410 | V/A |
| Current Monitor Voltage Swing (1) | 5mA Load | - | -12 | - | +12 | -12 | - | +12 | VOLTS |
| ERROR AMP | | | | | | | | | |
| E/A OUT Swing (1) | 5mA Load | - | -12 | - | +12 | -12 | - | +12 | VOLTS |
| Slew Rate (1) | | - | 6.5 | 8 | - | 6.5 | 8 | - | V/μSec |
| Gain Bandwidth Product (1) | | - | - | 6.5 | - | - | 6.5 | - | MHz |
| Large Signal Voltage Gain (1) | | - | 175 | 275 | - | 175 | 275 | - | V/mV |
| OUTPUT SECTION (1) | | | | | | | | | |
| Voltage Drop Across Bridge (1 Upper & 1 Lower) (1) | 30 AMPS | - | - | - | 1 | - | - | 1 | VOLTS |
| Voltage Drop Across Bridge (1 Upper & 1 Lower) (1) | 30 AMPS @ 150°C Junction | - | - | - | 1.83 | - | - | 1.83 | VOLTS |
| Leakage Current (1) (7) | All switches off, V+ = 60V, 150°C Junction | - | - | - | 750 | - | - | 750 | μA |
| Diode VSD (1) | | - | - | - | 2.6 | - | - | 2.6 | VOLTS |
| t _{rr} (1) | | - | - | 280 | - | - | 280 | - | nSec |
| Dead Time (1) | | - | - | 2 | - | - | 2 | - | μSec |

ELECTRICAL SPECIFICATIONS CONTINUED

NOTES:

- ① Guaranteed by design but not tested. Typical parameters are representative of actual device performance but are for reference only.
- ② Industrial grade devices shall be tested to subgroups 1 and 4 unless otherwise specified.
- ③ Military grade devices ("H" suffix) shall be 100% tested to subgroups 1, 2, 3 and 4.
- ④ Subgroup 5 and 6 testing available upon request.
- ⑤ Subgroup 1, 4 TA = TC = +25°C
 2, 5 TA = TC = +125°C
 3, 6 TA = TC = -55°C
- ⑥ Maximum power dissipation must be limited according to voltage regulator power dissipation. Tested with internal $\pm 15V$ loading.
- ⑦ Hybrid powered by external $\pm 15V$ supplies.
- ⑧ Measurements do not include offset current at 0V current command.
- ⑨ Continuous operation at or above absolute maximum ratings may adversely effect the device performance and/or life cycle.
- ⑩ When applying power to the device, apply the low voltage followed by the high voltage or alternatively, apply both at the same time. Do not apply high voltage without low voltage present.
- ⑪ Internal solder reflow temperature is 180°C, do not exceed.

APPLICATION NOTES

MSK4362 PIN DESCRIPTIONS

AV+, *BV+*, *CV+* - are the power connections from the hybrid to the bus. The pins for each phase are brought out separately and must be connected together to the *V+* source externally. The external wiring to these pins should be sized according to the RMS current required by the motor. These pins should be bypassed by a high quality monolithic ceramic capacitor for high frequencies and enough bulk capacitance for keeping the *V+* supply from drooping. 78 μF of ceramic capacitance and 6200 μF of bulk capacitance was used in the test circuit. The voltage range on these pins is from 16 volts up to 75 volts.

A \emptyset , *B \emptyset* & *C \emptyset* - are the connections to the motor phase windings from the bridge output. The wiring to these pins should be sized according to the required current by the motor. There are no short circuit provisions for these outputs. Shorts to *V+* or ground from these pins must be avoided or the bridge will be destroyed.

AVS, *BVS*, *CVS* - are the return pins on the bottom of each half bridge. They are brought out separately and should be connected together externally to allow the current from each half bridge to flow through the sense resistor. The wiring on these pins should be sized according to the current requirements of the motor.

RTN - is the power return connection from the module to the bus. All ground returns connect to this point from internal to the module in a star fashion. All external ground connections to this point should also be made in a similar fashion. The *V+* capacitors should be returned to this pin as close as possible. Wire sizing to this pin connection should be made according to the required current.

LGND - is an isolated ground connection to the *RTN* pin of the hybrid that is connected internally. For any circuitry that needs to be connected to the *RTN* pin without the influence of current flow through *RTN* should be connected at this point.

GND - is a ground pin that connects to the ground plane for all low powered circuitry inside the hybrid.

+REG IN - is the input pin for applying power to the internal +15V regulator. To use the regulator, connect the *+REG IN* pin to the motor bus (*V+*). See regulator app. note for more info on input voltage. If the +15V regulator is not needed, no connection should be made to *+REG IN* and *+15 VOUT*. +15 volts will have to be supplied from an external source to +15VIN. Absolute maximum voltage on this pin is 55 volts and minimum voltage is 18V. See voltage regulator portion of app. note for additional information.

+15 VOUT - is a regulated +15 volt output available for external uses. Up to 50 mA maximum is available at this pin. A 100 microfarad capacitor should be connected as close to this pin as possible and returned to GND along with a 0.22 microfarad monolithic ceramic capacitor. CAUTION: See Voltage Regulator Power Dissipation.

+15 VIN - is the input for applying +15 volts to run the low power section of the hybrid. This pin should be connected to +15 VOUT if running off of the internal regulator. The required bypassing of the +15 VOUT pin is sufficient in this case. For bringing in external +15 volts, this pin should be bypassed with a 10 μF capacitor and a 0.1 μF capacitor as close to this pin as possible.

-REG IN - is the input pin for applying power to the internal -15V DC - DC converter. To use the converter, connect the *-REG IN* pin to +15 VOUT pin. If the -15V converter is not needed, no connection should be made to *-REG IN* and *-15 VOUT*. -15 volts will have to be supplied from an external source to -15VIN. Also, L1 can be left open. See voltage regulator portion of app. note for important additional information.

L1 - is a pin for connecting an external inductor to the DC - DC converter for generating -15 volts. A 47 μH inductor capable of running at 250 KHz and about 1 amp of DC current shall be used. Connect the inductor between L1 and GND.

-15 VOUT - is a regulated -15 volt output available for external uses. Up to 50 mA maximum is available at this pin. A 100 microfarad capacitor should be connected as close to this pin as possible and returned to GND along with a 0.22 microfarad monolithic ceramic capacitor. CAUTION: See Voltage Regulator Power Dissipation

APPLICATION NOTES CONTINUED

-15 VIN - is the input for applying -15 volts to run the low power section of the hybrid. This pin should be connected to -15 VOUT if running off of the internal regulator. The required bypassing of the -15 VOUT pin is sufficient in this case. For bringing in -15 volts, this pin should be bypassed with a 10 μ F capacitor and a 0.1 μ F capacitor as close to this pin as possible.

CURRENT COMMAND (+,-) - are differential inputs for controlling the module in current mode. Scaled at ± 3 amps per volt of input command, the bipolar input allows both forward and reverse current control capability regardless of motor commutation direction. The maximum operational command voltage should be ± 10 volts for ± 30 amps of motor current.

CURRENT MONITOR - is a pin providing a current viewing signal for external monitoring purposes. This is scaled at ± 3 amps of motor current per volt output, up to a maximum of ± 10 volts, or ± 30 amps. As ± 30 amps is exceeded, the peaks of the waveform may become clipped as the rails of the amplifiers are reached. This voltage is typically ± 12.5 volts, equating to ± 37 amps of current peaks. In DIS mode, the CURRENT MONITOR output may rail positive or negative, depending on internal bias currents. When re-enabled, this output will resume expected operation.

E/A OUT - is the current loop error amp output connection. It is brought out for allowing various loop compensation circuits to be connected between this and E/A-.

E/A- - is the current loop error amp inverting input connection. It is brought out for allowing various loop compensation circuits to be connected between this and E/A OUT.

CLOCK SYNC - is an input for synchronizing to an external clock. The sync circuit will trigger on the edges of the applied clock and effectively shorten the period of the internal oscillator on each cycle. The frequency can be increased from a free running 22 KHz to 25 KHz maximum. The clock applied shall be 15 volts amplitude with at least a 10% duty cycle.

REFOUT - is a 6.25 volt regulated output to be used for powering the hall devices in various motors. Up to 15 mA of output current is available.

HALL A, B & C - are the hall input pins from the hall devices in the motor. These pins are internally pulled up to 6.25 volts. The halls can reflect a 120/240 degree commutation scheme or a 60/300 degree scheme.

BRAKE - is a pin for commanding the output bridge into a motor BRAKE mode. When pulled low, normal operation commences. When pulled high, the 3 high side bridge switches turn off and the 3 low side bridge switches turn on, causing rapid deceleration of the motor and will cease motor operation until pulled high again. Logic levels for this input are TTL compatible. It is internally pulled high.

DIS - is a pin for externally disabling the output bridge. A TTL logic low will enable the bridge and a TTL logic high will disable it. It is internally pulled up by a 100 μ Amp pullup.

60/120 - is a pin for selecting the orientation of the commutation scheme of the motor. A high state will produce 60/300 degree commutation, whereas a low state will produce 120/240 degree commutation. Logic levels for this input are TTL compatible. It is internally pulled high.

VOLTAGE REGULATOR POWER DISSIPATION - To figure voltage regulator power dissipation and junction temperature, use the following as an example:

Given:

V+ = 28V, MSK4362 +15V IQ = 90mA, -15V IQ = 40mA.

External Loads: +15V = 25 mA, -15V = 25 mA

-15V Converter Efficiency = 50%

PDiss due to +15V IQ, 90 mA x 13V = 1.17 W

PDiss due to -15V IQ, (40 mA / 0.5) x 13V = 1.04 W

PDiss due to +15V Ext load, 25 mA x 13V = 325 mW

PDiss due to -15V Ext load, (25 mA / 0.5) x 13V = 650 mW

PDiss Total = 1.17 W + 1.04 W + 325 mW + 650 mW = 3.19 W

3.19 W x 9°C/W = 28.7°C RISE above case temperature

Maximum Case Temperature = 150°C - 28.7°C = 121.3°C

To lower power dissipation in the regulator, a dropping resistor can be added in series from V+ to the +REG IN pin. Using the above example, if V+ = 39V and there is no dropping resistor, total power dissipation rises to about 5.88 watts. Temperature rise is now 52.9°C above case temperature, limiting maximum case temperature to 97.1°C. By adding a dropping resistor to lower the +REG IN pin voltage to 24.1V, the regulator power dissipation is lowered to 2.23 watts. Temperature rise is now 20.1°C above case temperature, allowing a maximum case temperature all the way to +125°C.

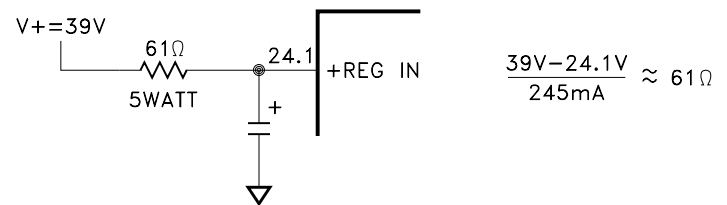

APPLICATION NOTES CONTINUED

ALTERNATE REGULATOR CONNECTION OPTIONS

By connecting the regulators in different ways, various capabilities can be obtained.

1. Higher than 55 volt operation - For operation at higher than 55 volt motor bus voltages, there are three options available:

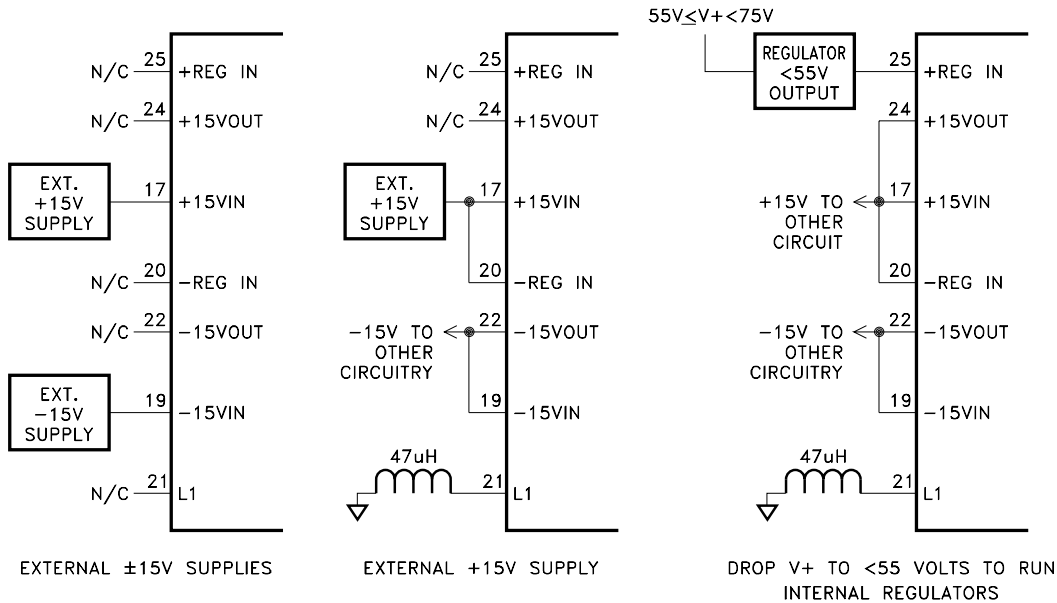

IMPORTANT NOTE ABOUT START UP:

When using the suggested inductor value (47µH) and output capacitor (47µF), the internal DC-DC converter (inverter) requires an input surge current of approximately 1.5A for 5mS at the -REG IN pin during start up. The +15V supply that is connected to the inverter input (-REG IN) must be capable of providing the start up surge current or the inverter could latch off into current limit. If the internal regulator is used to power the inverter, the same requirement applies to the +REG IN supply. As the -15VOUT capacitor value is increased, the pulse width of the start up current also increases proportionally. Also, since the DC-DC inverter is a basic switcher circuit, the normal operating DC input current (-REG IN) will always be twice that of the output current (-15VOUT).

COMMUTATION TRUTH TABLE

| HALL SENSOR PHASING | | | | | | ICOMMAND = POS. | | | ICOMMAND = NEG | | | BRAKE |
|---------------------|--------|--------|--------|--------|--------|-----------------|----|----|----------------|----|----|-------|
| 120° | | | 60° | | | AØ | BØ | CØ | AØ | BØ | CØ | |
| HALL A | HALL B | HALL C | HALL A | HALL B | HALL C | AØ | BØ | CØ | AØ | BØ | CØ | |
| 1 | 0 | 0 | 1 | 0 | 0 | H | - | L | L | - | H | 0 |
| 1 | 1 | 0 | 1 | 1 | 0 | - | H | L | - | L | H | 0 |
| 0 | 1 | 0 | 1 | 1 | 1 | L | H | - | H | L | - | 0 |
| 0 | 1 | 1 | 0 | 1 | 1 | L | - | H | H | - | L | 0 |
| 0 | 0 | 1 | 0 | 0 | 1 | - | L | H | - | H | L | 0 |
| 1 | 0 | 1 | 0 | 0 | 0 | H | L | - | L | H | - | 0 |
| 1 | 1 | 1 | 1 | 0 | 1 | - | - | - | - | - | - | 0 |
| 0 | 0 | 0 | 0 | 1 | 0 | - | - | - | - | - | - | 0 |
| X | X | X | X | X | X | L | L | L | L | L | L | 1 |

1 = High Level
0 = Low Level
X = Don't Care

H = SOURCE
L = SINK
- = OPEN

NOTE: Because of the true 4 quadrant method of output switching, the output switches will PWM between the ICOMMAND POSITIVE and ICOMMAND NEGATIVE states, with the average percentage based on ICOMMAND being a positive voltage and a negative voltage. With a zero voltage ICOMMAND, the output switches will modulate with exactly a 50% duty cycle between the ICOMMAND POSITIVE and ICOMMAND NEGATIVE states.

APPLICATION NOTES CONTINUED

BUS VOLTAGE FILTER CAPACITORS

The size and placement of the capacitors for the DC bus has a direct bearing on the amount of noise filtered and also on the size and duration of the voltage spikes seen by the bridge. What is being created is a series RLC tuned circuit with a resonant frequency that is seen as a damped ringing every time one of the transistors switches. For the resistance, wire resistance, power supply impedance and capacitor ESR all add up for the equivalent lumped resistance in the circuit. The inductance can be figured at about 30 nH per inch from the power supply. Any voltage spikes are on top of the bus voltage and the back EMF from the motor. All this must be taken into account when designing and laying out the system. If everything has been minimized, there is another solution. A second capacitance between 5 and 10 times the first capacitor and it should either have some ESR or a resistor can be added in series with the second capacitor to help damp the voltage spikes.

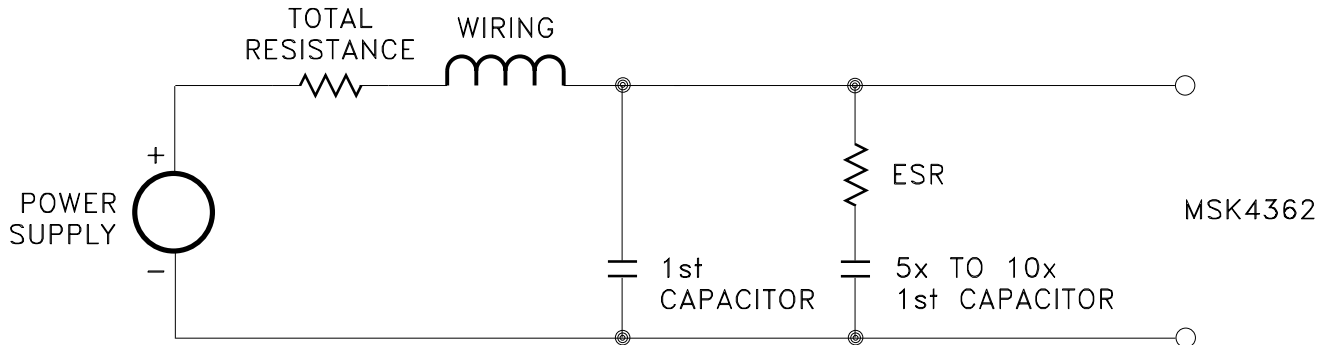

Be careful of the ripple current in all the capacitors. Excessive ripple current, beyond what the capacitors can handle, will destroy the capacitors.

REGULATED VOLTAGE FILTER CAPACITORS

It is recommended that 47 μ F of capacitance (tantalum electrolytic) for bypassing the + and -15V regulated outputs be placed as close to the module pins as practical. Adding ceramic bypass capacitors of about 0.1 μ F or 1 μ F will aid in suppressing noise transients.

GENERAL LAYOUT

Good PC layout techniques are a must. Ground planes for the analog circuitry must be used and should be tied back to the small pin grounds 9, 14 and 23. Additional ground, pin 26 is an isolated ground that connects internally directly back to the main DC bus ground pin 27. This can be used as necessary for voltage sensing, etc.

LOW POWER STARTUP

When starting up a system utilizing the MSK4362 for the first time, there are a few things to keep in mind. First, because of the small size of the module, short circuiting the output phases either to ground or the DC bus will destroy the bridge. The current limiting and control only works for current actually flowing through the bridge. The current sense resistor has to see the current in order for the electronics to control it. If possible, for startup use a lower voltage and lower current power supply to test out connections and the low current stability. With a limited current supply, even if the controller locks up, the dissipation will be limited. By observing the E/A OUT pin which is the error amp output, much can be found out about the health and stability of the system. An even waveform with some rounded triangle wave should be observed. As current goes up, the DC component of the waveform should move up or down. At full current (with a regular supply) the waveform should not exceed +8 volts positive peak, or -8 volts negative peak. Some audible noise will be heard which will be the commutation frequency. If the motor squeals, there is instability and power should be removed immediately unless power dissipation isn't excessive due to limited supply current. For compensation calculations, refer to the block diagram for all information to determine the amplifier gain for loop gain calculations.

MSK4362 TEST CIRCUIT

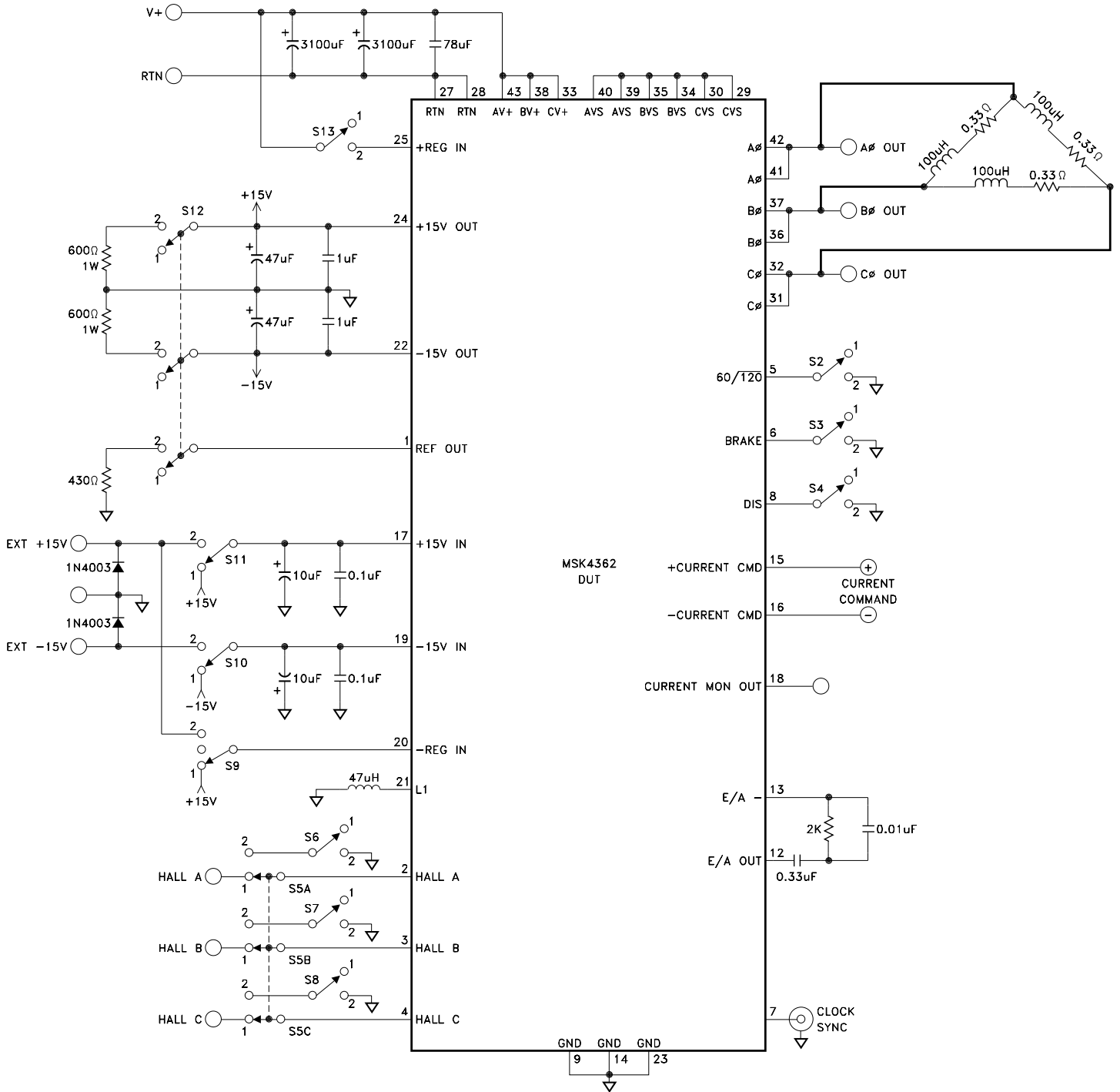

TYPICAL TEST SCHEMATIC

MECHANICAL SPECIFICATIONS

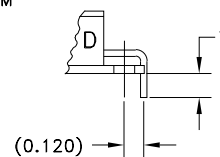
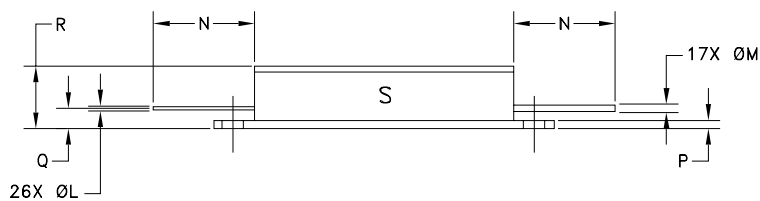
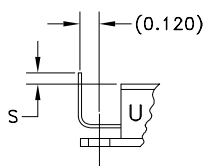
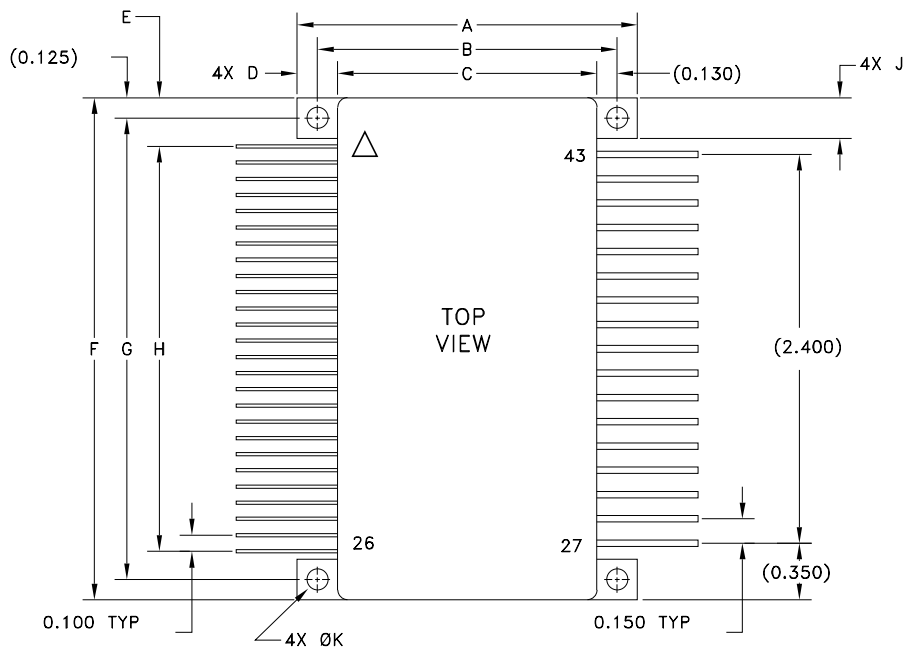

| REF | MIN | MAX | REF | MIN | MAX |
|-----|-------|-------|-----|-------|-------|
| A | 2.090 | 2.110 | K | 0.142 | 0.149 |
| B | 1.850 | 1.870 | L | 0.018 | 0.022 |
| C | 1.590 | 1.610 | M | 0.038 | 0.042 |
| D | 0.245 | 0.255 | N | 0.600 | 0.750 |
| E | 0.290 | 0.310 | P | 0.055 | 0.065 |
| F | 3.090 | 3.110 | Q | 0.180 | 0.190 |
| G | 2.840 | 2.860 | R | | 0.395 |
| H | 2.490 | 2.510 | S | 0.120 | |
| J | 0.245 | 0.255 | T | 0.120 | |

ESD TRIANGLE INDICATES PIN 1
WEIGHT = 88 GRAMS TYPICAL

ALL DIMENSIONS ARE SPECIFIED IN INCHES

ORDERING INFORMATION

MSK4362 H U

LEAD CONFIGURATION

S = STRAIGHT, U = BENT UP, D = BENT DOWN

SCREENING

BLANK = INDUSTRIAL; H = MIL-PRF-38534 CLASS H

GENERAL PART NUMBER

THE ABOVE EXAMPLE IS A MILITARY GRADE DEVICE WITH LEADS BENT UP.

REVISION HISTORY

| REV | STATUS | DATE | DESCRIPTION |
|-----|----------|-------|---|
| M | Released | 01/15 | Add internal note and clarify mechanical specifications. |
| N | Released | 12/18 | Change sense resistor to 0.008 ohm and current sense gain to 6.24X |
| P | Released | 02/19 | Change sense resistor back to 0.010 ohm and current sense gain back to 5X |
| R | Released | 10/21 | Relocated ESR to be in series with capacitor |
| T | Released | 08/22 | Change sense resistor to 0.008 ohm and current sense going to 6.24X |

TTM Technologies
www.ttmtech.com

The information contained herein is believed to be accurate at the time of printing. TTM Technologies reserves the right to make changes to its products or specifications without notice, however and assumes no liability for the use of its products. Please visit our website for the most recent revision of this data sheet.