

MSK4363 Evaluation Board User's Guide

By Dan Williams, MS Kennedy Corp.; 6/2014

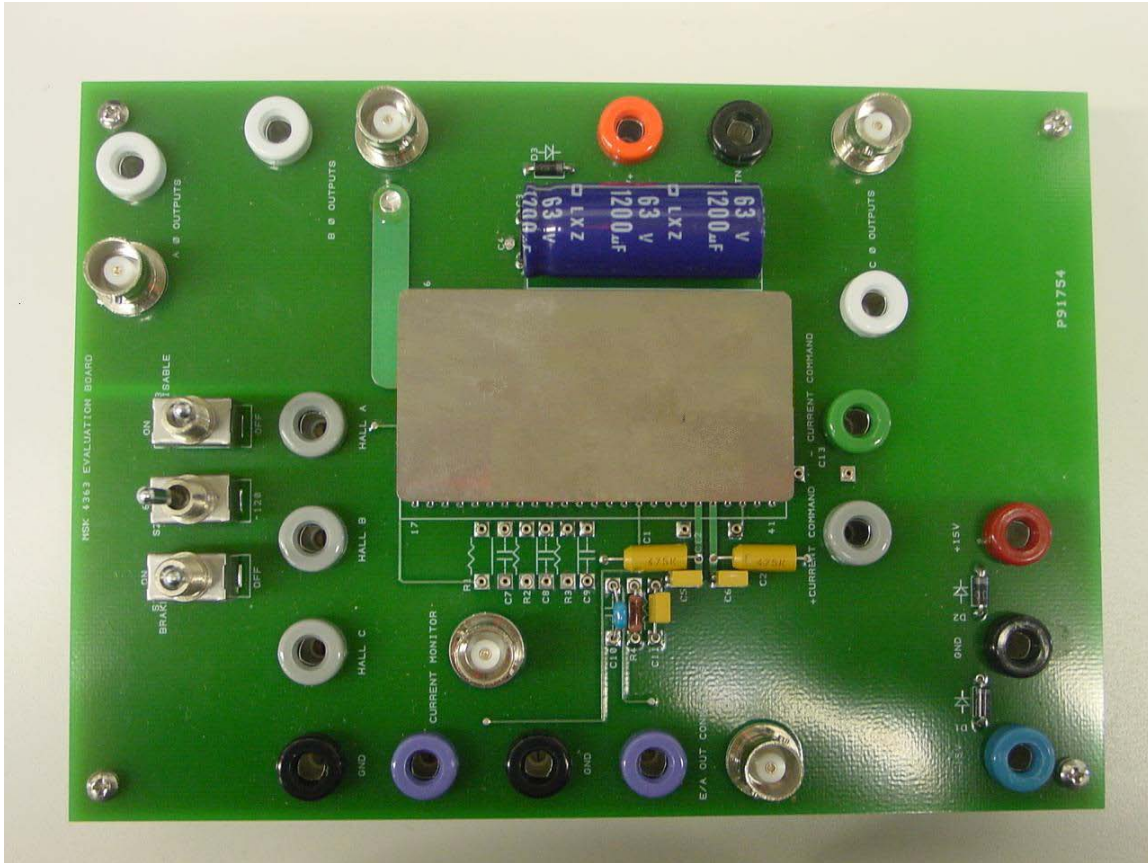

Introduction

The MSK 4363 is a complete 3 Phase MOSFET Bridge Brushless Motor Control System in an electrically isolated hermetic package. The hybrid is capable of 10 amps of output current and 75 volts of DC bus voltage. It has the normal features for protecting the bridge. Included is all the bridge drive circuitry, hall sensing circuitry, commutation circuitry and all the current sensing and analog circuitry necessary for closed loop current mode (torque) control. When PWM'ing, the transistors are modulated in locked anti-phase mode for the tightest control and the most bandwidth. Provisions for applying different compensation schemes are included. The MSK 4363 has good thermal conductivity of the MOSFET's due to isolated substrate/package design that allows direct heat sinking of the hybrid without insulators.

This configuration can be used to control a variety of loads, such as a brushed DC motor or a voice coil. Because of the internal PWM generator, all the user needs to do is provide an analog voltage representative of the PWM duty cycle desired on the output.

The evaluation board provides a platform from which to evaluate new designs with ample real estate to make changes and evaluate results. Evaluation early in the design phase reduces the likelihood of excess ripple, instability, or other issues, from becoming a problem at the application PCB level.

This application note is intended to be used in conjunction with the MSK4363 data sheet. Reference the device data sheet for additional application information and specifications.

Setup

Use the standard 4mm banana jacks to interface with the assembly to connect to your power supply and motor assembly. Use the BNC interface connections for monitoring the phases, and for your analog input for setting the speed and direction.

Design Details

Device Block Diagram

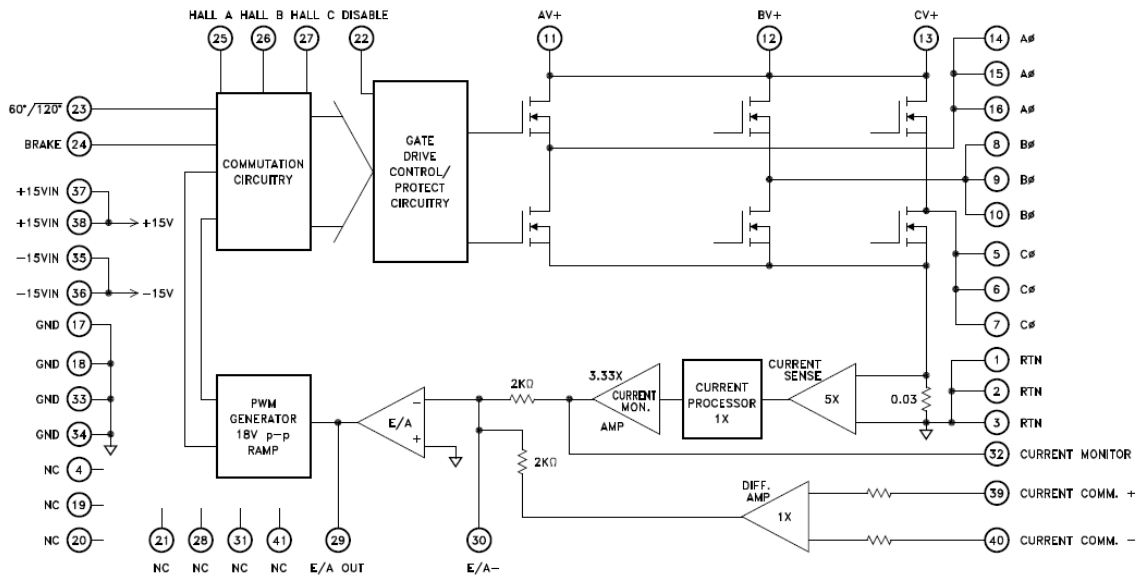

PCB Artwork

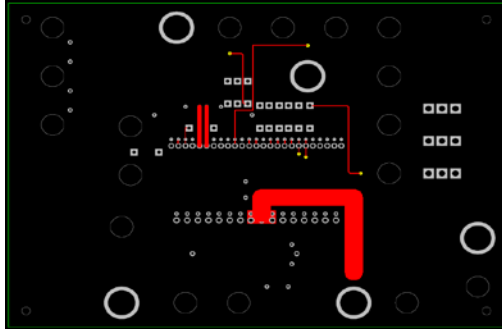

Top Side

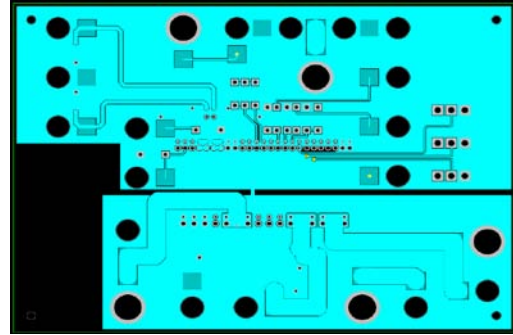

Bottom Side

Schematic

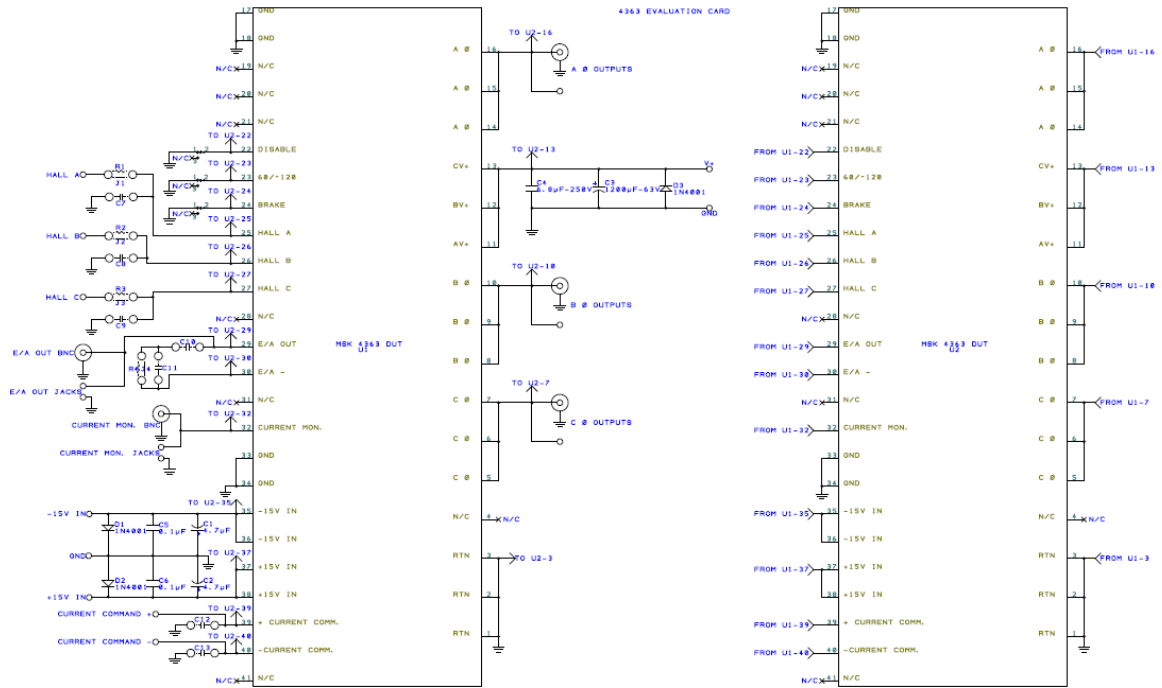

Bill Of Materials

REF DES/QTY	VALUE	MANUFACTURER	GENERIC PART #
R1-R4	OPTIONAL	N/A	N/A
S1, S2, S3	SPDT	NKK	M2012SS1W01
C7-C13	OPTIONAL	N/A	N/A
C1, C2	4.7 μ F	KEMET	T322D475K050AT
C5, C6	0.1 μ F	AVX	CK05BX104K
C4	6.8 μ F, 100V	ILLINOIS CAPACITOR	685MWR100K
C3	1200 μ F, 63V	United Chemi-Con	ELXZ630ELL122ML40S
D1, D2, D3	1N4001		1N4001
17	BANANA JACKS	EMERSON/JOHNSON	108-09XX-001
5	BNC'S	TE Connectivity	1-1337542-0
48	.015/.025 DIA PIN RECEPT	MILL MAX	0677-0-15-01-30-27-10-0
16	.022/.032 DIA PIN RECEPT	MILL MAX	0295-0-15-01-06-27-10-0
4	7/8", #4, STANDOFFS		
4	3/8", #4, SCREWS		
1	MSK 4363	MSK	
1	MSK 4363 EVAL BOARD	ADVANCED CIRCUITS	