

**AIR Radio Module, with U.FL Antenna Port
2.4 GHz**



Description:

The A2500R24C is a high-performance, FCC & IC certified and ETSI-compliant connectorized radio module that incorporates the Texas Instruments CC2500 transceiver chip, all in the industry's smallest package: 9 x 12 x 2.5mm.

Features:

- Frequency range: 2400-2483.5 MHz
- FCC, IC and ETSI-compliant, shielded package
FCC ID: X7J-A10030501
IC: 8975A-A10030501
- Digital RSSI output
- Programmable output power up to +1.0dBm
- High sensitivity (2.4 kBaud, 1% packet error rate)
-104 dBm at 2442 MHz
(compliant to FCC/IC/ETSI)
- Ultra-small package size: 9 x 12 x 2.5mm
- Industry-standard U.FL connector
- LGA footprint
- RoHS compliant
- Operating temperature -40 to +85°C
- Impedance-controlled, multi-layer PCB
- 1.8 to 3.6 VDC
- Low current consumption (16 mA in RX, 250 kBaud, 2442 MHz)
- 400 nA sleep mode current consumption
- Efficient SPI interface; all registers can be programmed with one "burst" transfer
- Available in tape & reel and matrix tray
- Module weight approximately 0.4 grams

Benefits:

- Minimal RF engineering experience necessary
- No additional "Intentional Radiator" certification required (FCC 15.247a2, IC RSS-210, ETSI EN 300 328)
- Minimal real estate required
- Easily implemented on a two layer PCB
- No additional harmonic filtering required
- 100% RF-tested in production
- Common footprint for similar products in family
- No additional DC decoupling required
- Integrated analog temperature sensor
- Excellent receiver selectivity and blocking performance
- Suitable for frequency hopping systems, thanks to a fast-settling frequency synthesizer with 90 µs settling time
- Impedance-matched balun for optimized efficiency
- Support for asynchronous and synchronous serial receive/transmit mode for backwards compatibility with existing radio communication protocols

Block Diagram:

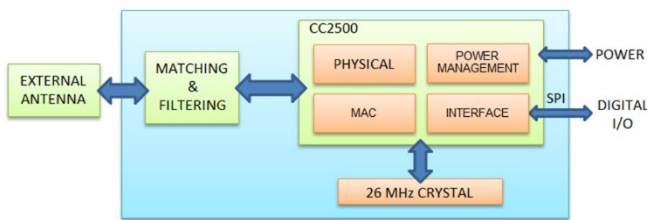

The item described in this product brief is part of our total AIR Support solution. To learn more, visit our website or just ask us!

PLEASE NOTE: Additional information on the Texas Instruments CC2500 device can be found in the company's latest datasheet release at <http://www.ti.com>



This product is not to be used in any implantable medical device or external medical device intended to regulate or monitor biological functions, including but not limited to devices such as pacemakers, defibrillators, cardiac resynchronization devices, pressure sensors, biochemical stimulators and neurostimulators. TTM MAKES NO WARRANTY OF FITNESS OR MERCHANTABILITY OF THIS PRODUCT FOR ANY USE OF THIS TYPE. TTM shall not be responsible for any consequential damages arising from the sale or use of this product for any use of this type. The ultimate user of the product assumes all risk of personal injury or death arising from a prohibited use.

Product Overview:

The A2500R24C is a high-performance, FCC & IC certified and ETSI-compliant connectorized radio module that incorporates the Texas Instruments CC2500 transceiver chip in the industry's smallest package (9 x 12 x 2.5mm) and is compatible with all TI-approved software stacks.

With an LGA pad footprint and industry-standard U.FL button connector receptacle, this module is designed to effortlessly integrate into a wide range of applications, including: industrial control, building automation, low-power wireless sensor networks, lighting control, and automated meter reading.

The A2500R24C has an RoHS-compliant ENIG finish and is packaged on tape & reel or in matrix trays for high-volume automated manufacturing.

Pin Diagram:

Viewed from Top Side
NC = "NO Connection"
Pin is NOT connected internally.

DNC = "Do Not Connect" Pin reserved for internal use, ensure mating footprint pads are **isolated**.

GND = "Ground"
Connect the maximum number possible (minimum **one** for proper operation).

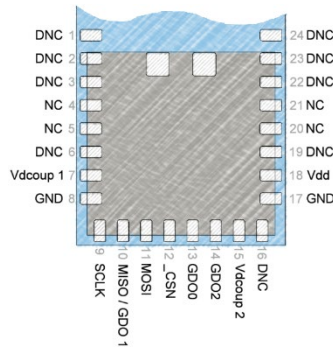

Nomenclature:



| Item | Description |
|------------------|---------------------------------------|
| 1 Chip series | (CC1101, CC110L, CC2500) |
| 2 Function | (R = radio only) |
| 3 Frequency band | (x100MHz) |
| 4 Form factor | (A = Internal Antenna, C = Connector) |
| 5 Design ID | (00 = Default) |
| 6 Application | (G = General) |
| 7 Packaging | (R = Tape/Reel, M = Matrix Tray) |

Layout Information:

Top 2 pads optional for compatibility with other modules. Refer to User's Manual for additional layout guidelines. Dimensions in mm.

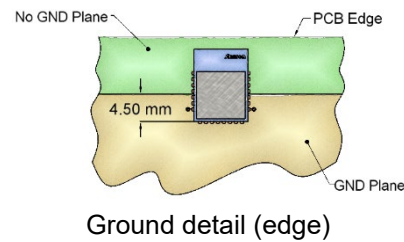
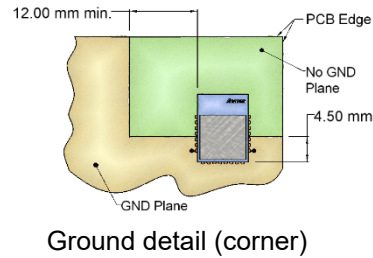
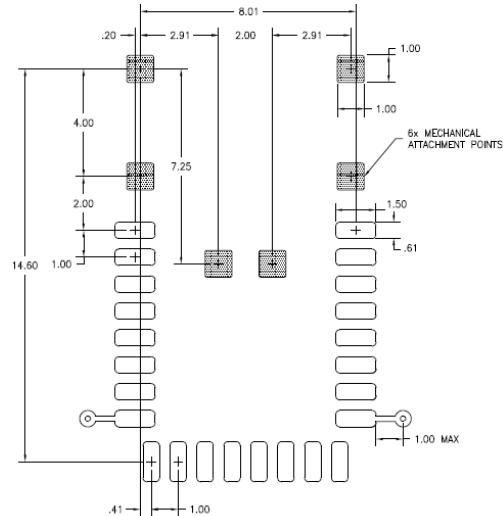

Caution! ESD sensitive device. Precautions should be used when handling the device in order to prevent permanent damage.



MSL 3

Contact us:
rf&s_support@ttm.com

