

Surface Mount RF Termination
5 Watts, 50Ω

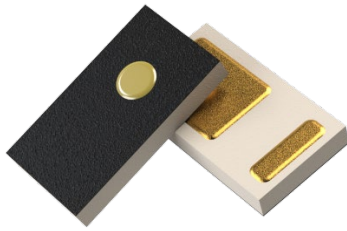

Description:

The Xinger C5A50Z5-F12 is a high-performance Alumina (Al₂O₃) surface mount RF 50 Ohm termination optimized for leading performance over DC-12GHz frequency range (L, S, C, X Bands). The RoHS compliant and ENIG plated termination is well suited for all Mil-Aero, industrial and commercial applications to 12GHz. This termination is ideal for use with Xinger couplers and for use in microstrip circuits.

Features:

- DC-12 GHz
- Power 5 Watts (AVG)
- Return Loss (>20 dB)
- All end market applications
- 100% RF Tested
- 12dB Peak to AVG Power
- RoHS Compliant
- Durable ENIG Finish

General Specifications:

Impedance	50 Ohms
Resistive Element	Thick film
Substrate	Al ₂ O ₃ Ceramic
Terminal Finish	Electroless Nickel Immersion Gold (ENIG)
Operating Temperature	-55 to +150°C (see derating chart)

Electrical Specifications:

Frequency GHz	Power Avg. Watts @ 100°C	Return Loss dB Min
DC – 8.5	5	20
8.5 - 12.0	5	18

Specifications based on unit properly installed using suggested mounting instructions and a 50 ohm nominal impedance. Specifications subject to change.

Mechanical Outline:

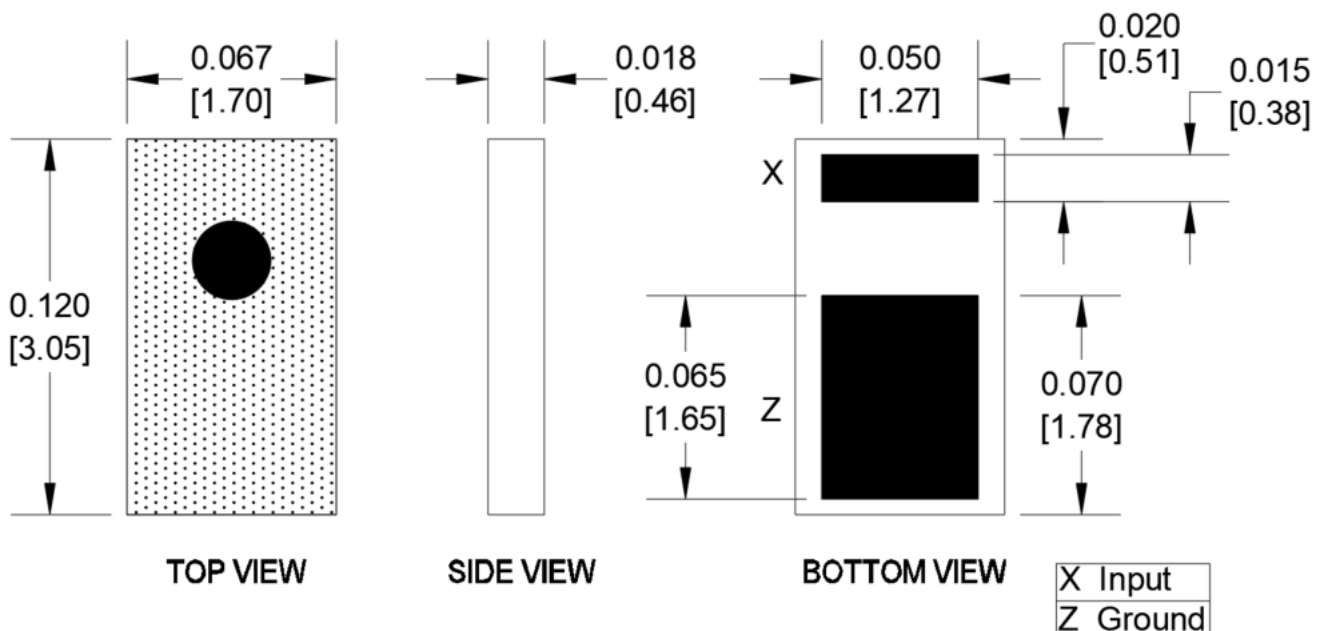

Tolerance is ±0.005", unless otherwise specified. All dimensions in inches [millimeters].

Typical Performance:

Return Loss:

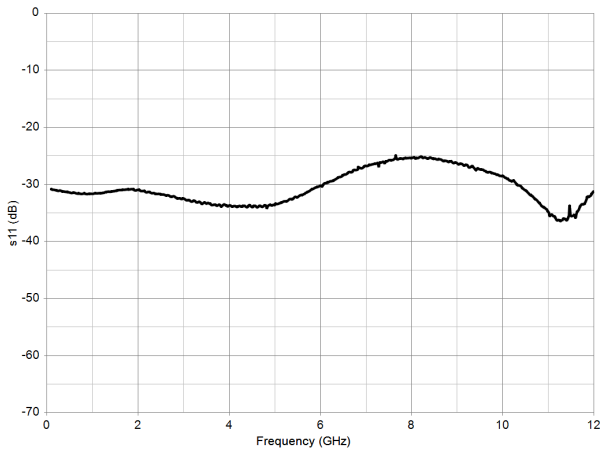

Impedance:

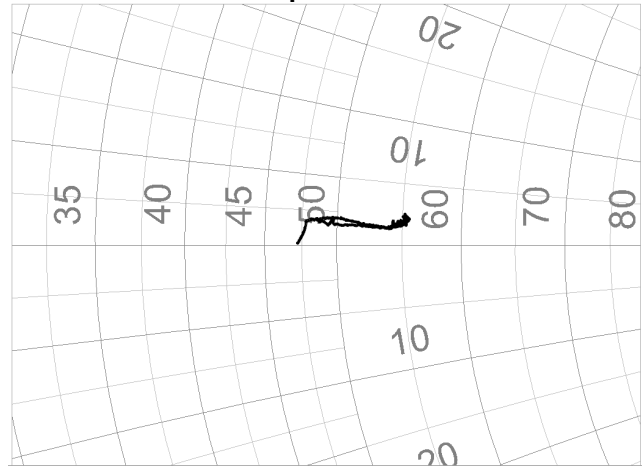

Mounting Footprint:

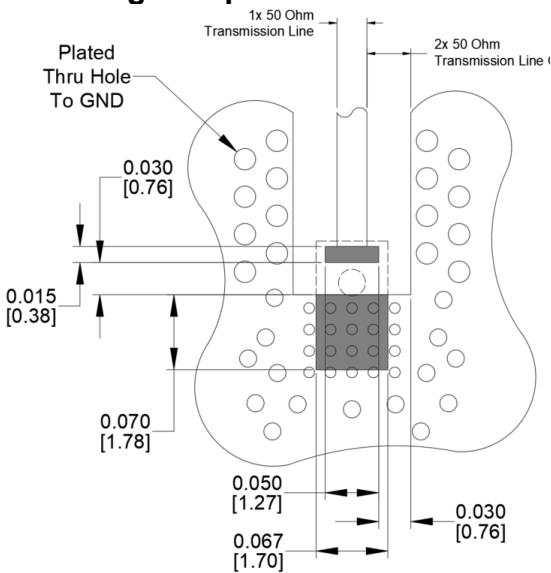

1. The component has been designed and qualified with this mounting footprint with a 0.020" test board with Dk value of approximately 3.5 comprised of commonly used board substrate materials such as RO4350 and Isola I-tera MT40. Deviations from the recommended mounting footprint may reduce RF and power handling performance. It is the customer's responsibility to qualify the component in the end application.
2. 1x 50 ohm transmission line is for reference only and can be oriented in any direction. Customer to determine transmission line and gap dimensions to achieve 50 ohm impedance for end application.
3. To ensure proper electrical and thermal performance there must be a ground plane with 100% solder connection underneath the part orientated as shown with part marking facing up.
4. PTH connecting pads to ground are representative.
5. Ground vias under part should be filled to prevent solder wicking.
6. Solder mask and solder stencil dimensions may vary due to different manufacturer capabilities and process variations. Layers may be modified to account for manufacturer capabilities.
7. Dimensions are in inches [millimeters].

Power Derating:

C5A50Z5-F12 Power Derating Curve

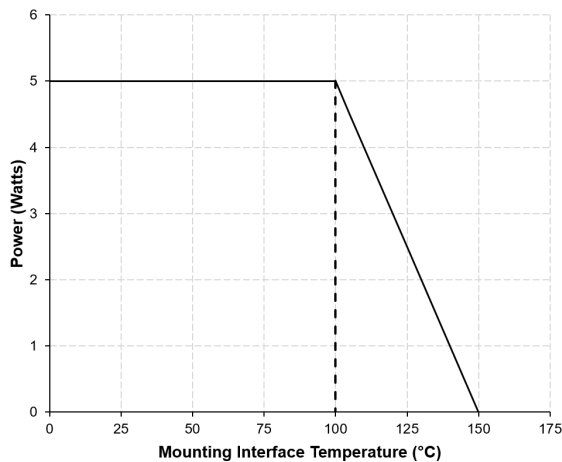

Packaging and Ordering Information:

Parts are available in reels. Parts are oriented in tape and reel as shown below.

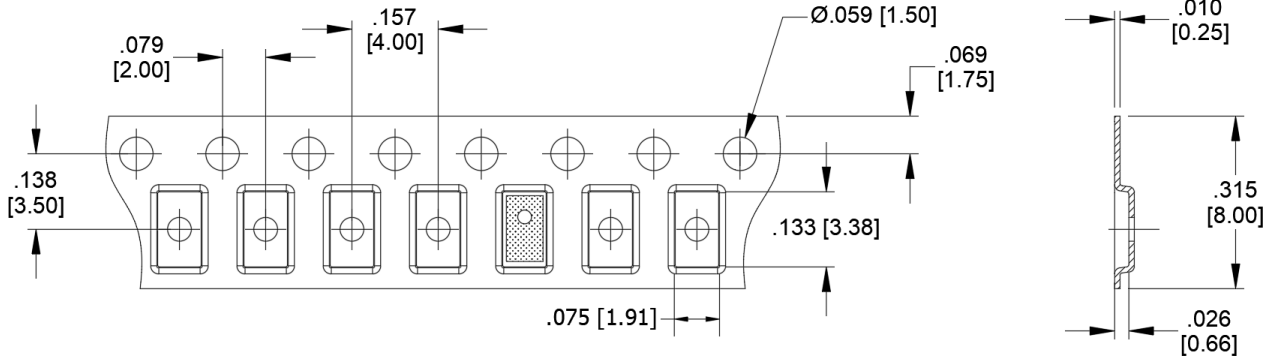

Dimensions are in Inches [Millimeters]

Direction of Part Feed (Unloading)

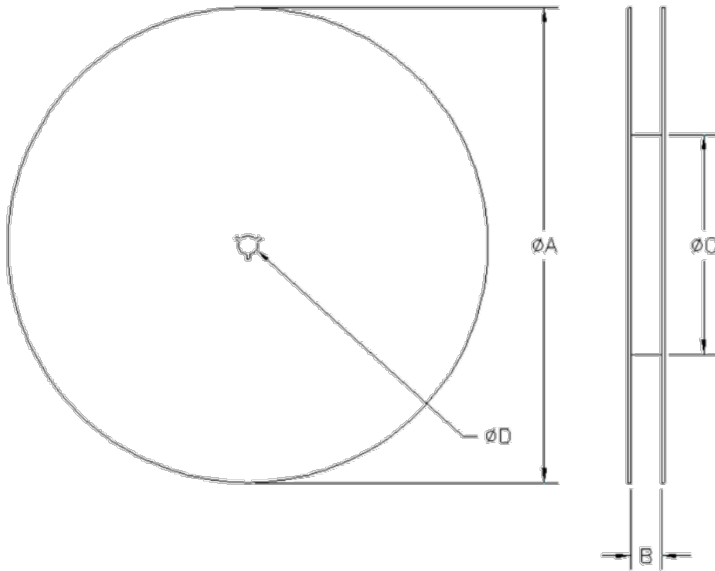

TABLE 1	REEL DIMENSIONS inches [mm]
ØA	7.0 [177.80]
B	0.315 [8.00]
ØC	2.00 [50.80]
ØD	0.512 [13.00]

Contact us:
rf&s_support@ttm.com