

Xinger III



Description:

The X3DC08F1AS is a low profile, high performance Doherty Combiner, in a new easy to use, XINGER® style manufacturing friendly surface mount package. The X3DC08F1AS is designed particularly for Doherty Amplifier applications, where a tightly controlled phase of 90 degrees, 1:1 splitting ratio and low insertion loss are required for maximum and low power condition. It can be used in high power applications.

Parts have been subjected to rigorous XINGER® qualification testing and they are manufactured using materials with coefficients of thermal expansion (CTE) compatible with common substrates such as FR4, RF-35, RO4350 and polyimide. Produced with 6 of 6 RoHS compliant tin immersion finish.

Features:

- 862-894 MHz
- Doherty Amplifier Applications
- 1:1 Splitting
- Power 25 Watts (AVG)
- Low Amp Imbalance
- Low Loss (<0.35dB)
- Production Friendly
- Tape and Reel
- Lead Free
- Tin-Immersion Finish
- Made in the USA

Electrical Specifications**

Frequency	Return Loss ^[1]	Insertion Loss ^[1]	Amplitude Imbalance ^[1]	Phase Imbalance ^[1]
MHz	dB Min	dB Max	dB Max	Degrees
862-894	22	0.35	±0.2	90 ± 4.0
Operating Temp.	Return Loss ^[2]	Insertion Loss ^[2]	Port Extension ^[3]	Power
°C	dB Min	dB Max	Degrees	AVG Watts @105°C
-55 to +150	20	0.35	0	25

**Specification based on performance of unit properly installed on TTM Technologies Test Board.

[1] At maximum power condition, Doherty combiner functions as a 1:1 power combiner.

[2] At low power condition, Doherty combiner works as an impedance transformer (see page below)

[3] At low power condition, the offset lines at the input need to be adjusted by 0 deg. (if required) (see page below)

[4] Average power handling which represents low power mode.

Mechanical Outline:

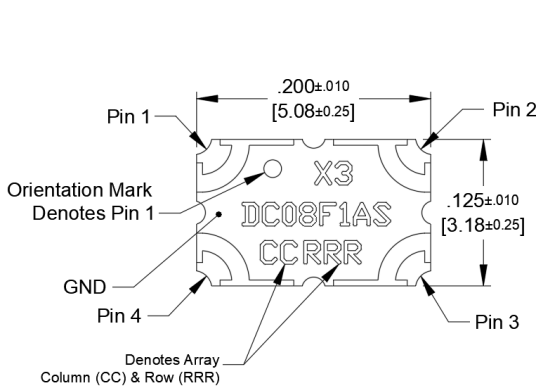

Dimensions are in Inches [Millimeters]
X3DC08F1AS Mechanical Outline

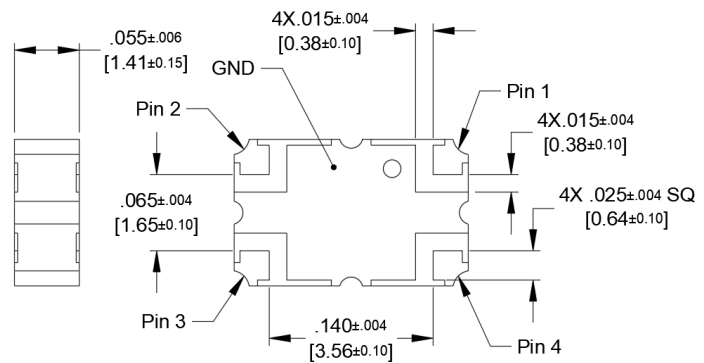

Tolerances are Non-Cumulative

Doherty Amplifier Configuration

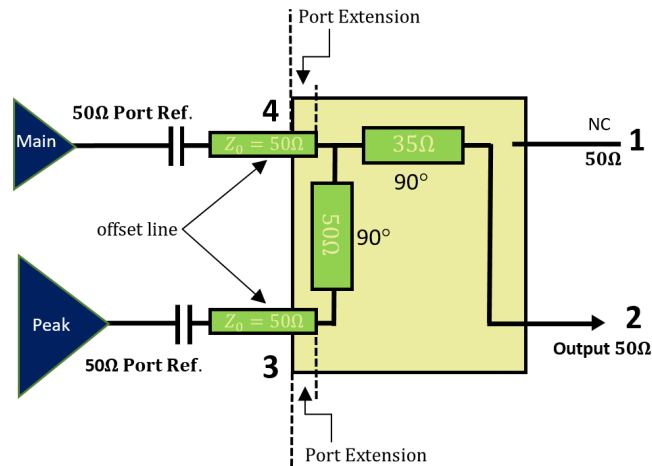

1:1 Inverted Doherty Combiner

Doherty Combiner Pin Configuration

The X3DC08F1AS has an orientation marker to denote Pin 1. Once port one has been identified the other ports are known automatically. Please see the chart below for clarification:

Pin 1	Pin 2	Pin 3	Pin 4
Not Connected	Combining Port	Peak Amp Port	Main Amp Port

Peak Power Handling

High-Pot testing of these component during the qualification procedure resulted in a minimum breakdown voltage of 1.24Kv (minimum recorded value). This voltage level corresponds to a breakdown resistance capable of handling at least 12dB peak over average power levels, for very short durations. The breakdown location consistently occurred across the air interface at the component contact pads (see illustration below). The breakdown levels at these points will be affected by any contamination in the gap area around these pads. These areas must be kept clean for optimum performance. It is recommended that the user test for voltage breakdown under the maximum operating conditions and over worst case modulation induced power peaking. This evaluation should also include extreme environmental conditions (such as high humidity).

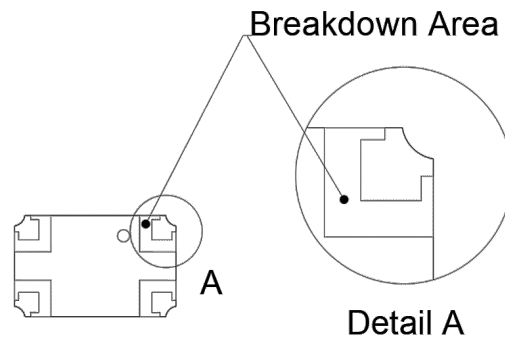

Insertion Loss and Power Derating Curves

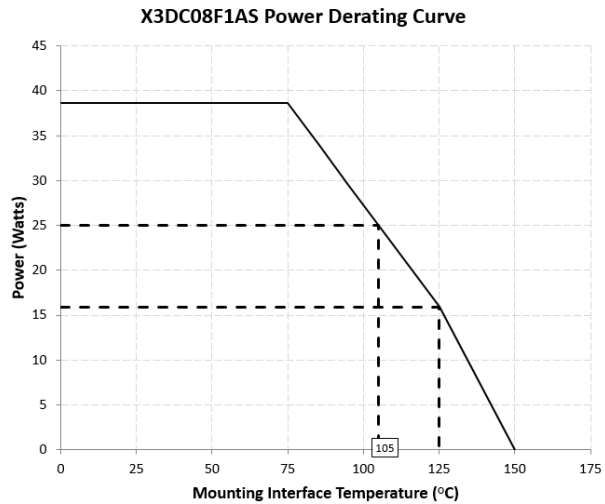
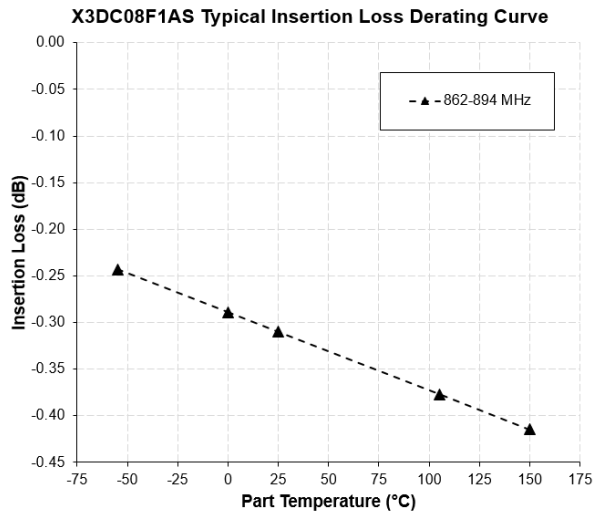

Insertion Loss Derating:

The insertion loss, at a given frequency, of a group of doherty combiners is measured at 25°C and then averaged. The measurements are performed under small signal conditions (i.e. using a Vector Network Analyzer). The process is repeated at 105°C and 150°C. A best-fit line for the measured data is computed and then plotted from -55°C to 150°C.

Power Derating:

The power handling and corresponding power derating plots are a function of the thermal resistance, mounting surface temperature (base plate temperature), maximum continuous operating temperature of the Doherty combiner, and the thermal insertion loss. The thermal insertion loss is defined in the Power Handling section of the data sheet.

As the mounting interface temperature approaches the maximum continuous operating temperature, the power handling decreases to zero.

If mounting temperature is greater than 105°C, the XINGER® doherty combiner will perform reliably as long as the input power is derated to the curve above.

Typical Performance: 862-894 MHz

Typical Performance Under Maximum Power Conditions:

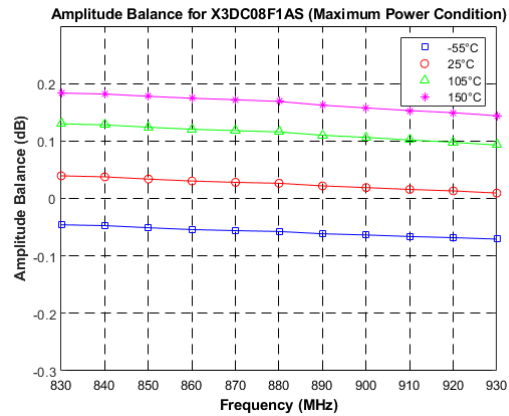
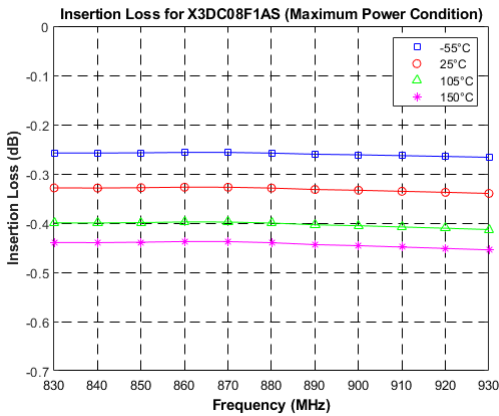
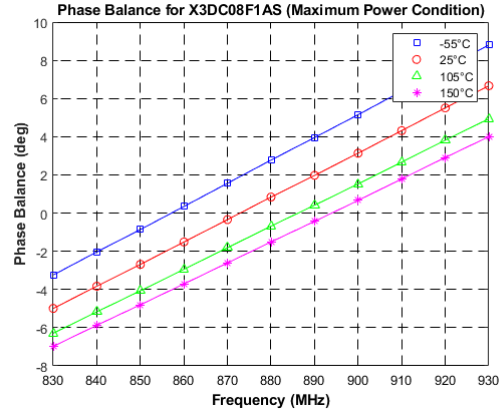
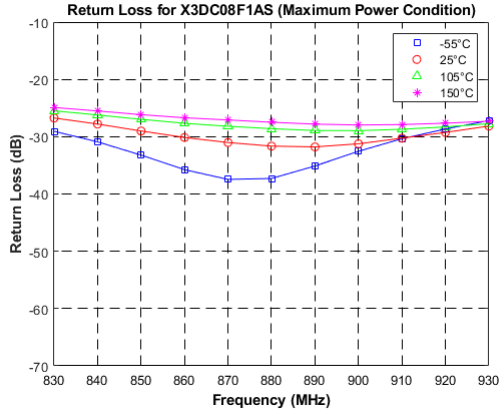

Typical Performance Under Low Power Conditions:

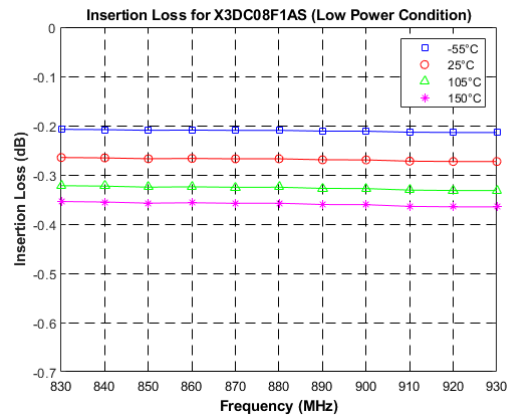
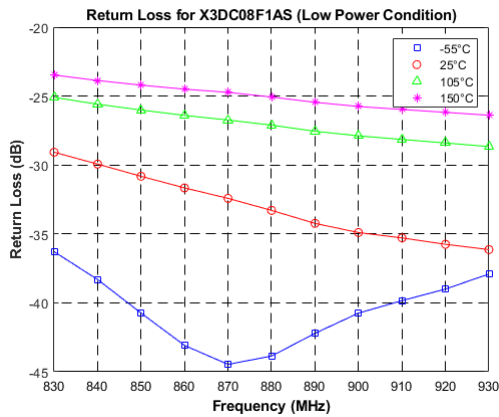

Definition of the Specifications

To guarantee the part performance in Doherty architecture, the part is specified in Doherty operation for maximum power condition and low power condition. The following specification definition assumes the extra port extension is already applied to the raw S parameter and the parts is measured with Pin n connected to Port n (where n=1, 2, 3, 4).

Maximum power condition

Under the maximum power condition, the Doherty architecture requires main amplifier and peak amplifier to work at full capacity with Main at 50Ω and Peak at 50Ω. The two amplifiers should deliver RF power ratio of 1:1 and 90 degree phase difference.

Parameter	Definition	Mathematical Representation
Return Loss	The impedance match at the combining port to a 50Ω system.	$20 \log S_{22} $
Insertion Loss	The combined power divided by the sum of input power under the perfect combining condition.	$10 \log(S_{23}^2 + S_{24}^2)$
Amplitude Imbalance	The magnitude difference between Main-Combined path and Peak-Combined path under the perfect combining condition.	$\frac{20 \log S_{24} - 20 \log S_{23} }{2}$
Phase Imbalance	The phase difference between Peak-Combined path and Main-Combined path at $\omega_c=878\text{MHz}$.	$\text{Phase}(S_{24}(\omega_c)) - \text{Phase}(S_{23}(\omega_c))$

Low power condition

Under low power condition, the Doherty operation turns off peak amplifier and requires main amplifier to be terminated with impedance of 25Ω. In this configuration, Doherty combiner serves as an impedance transformer, transforming 50Ω at combining port to 25Ω at main amplifier port. The following specification is defined under the port impedance condition of Port 2 (Combining Port) 50Ω, Port 4 (Main Amp Port) 25Ω and Port 3 (Peak Amp Port) terminated with a short (low impedance).

Port Extension:

There are inevitably short lines associating with input ports in some high frequency band parts. The length of the short line is specified as electrical length at center frequency and referred as port extension in this datasheet. The designer should take this length into the account to optimize the offset line length. The return loss and insertion loss specified in the Electrical Specifications table are after incorporating port extension.

Parameter	Definition	Mathematical Representation
Return Loss	The impedance match of the 50Ω to 25Ω transformer.	$20 \log S_{22} $
Insertion Loss	The output power divided by input power.	$20 \log S_{24} $

Packaging and Ordering Information

Parts are available in reels. Packaging follows EIA 481 for reels. Parts are oriented in tape and reel as shown below. Tape and reel is available in 4000 pcs per reel.

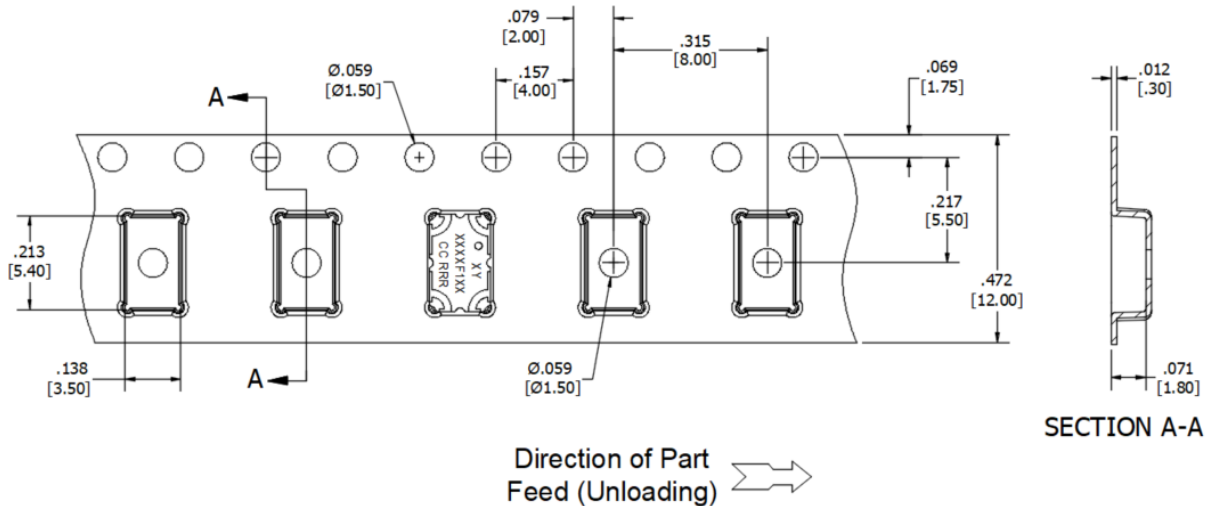

Dimensions are in Inches [Millimeters]

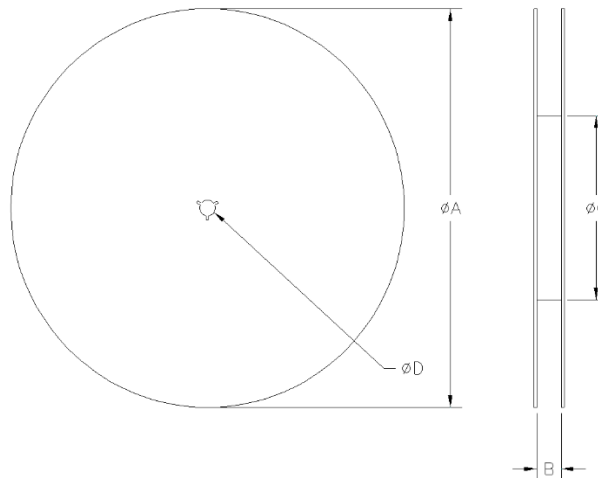

TABLE 1	
REEL DIMENSIONS (inches [mm])	
φA	13.0 [330.0]
B	.472 [12.0]
φC	4.017 [102.03]
φD	0.512 [13.0]

Contact us:
rf&s_support@ttm.com