

Xinger[®] III

90° Phase Shifter



Description:

The XPS30F190S is a low profile, high performance 90 degree phase shifter in an easy to use, manufacturing friendly Xinger[®] style surface mount package. XPS30F190S can also provide 180 degree phase shift by connecting the two internal pins. It can be used in medium power applications up to 20 Watts (AVG) and has a Peak to Average power ratio of 12dB.

Parts have been subjected to rigorous qualification testing and they are manufactured using materials with coefficients of thermal expansion (CTE) compatible with common substrates such as FR4, G-10, RF-35, RO4003 and polyimide. Produced with 6 of 6 RoHS compliant tin immersion finish.

Features:

- 2620 - 3000 MHz
- Medium Power 20 Watts (AVG)
- Peak to Average ratio 12dB
- Very Low Loss
- Tight Phase
- Production Friendly
- Tape and Reel
- Lead-Free
- Made in the USA

Electrical Specifications*:

Frequency MHz	Insertion Phase @ 3GHz degree	Insertion Loss dB Max
2620 - 2690	80.7 ± 5	0.20
2900 - 3000	90.0 ± 5	0.20
Return Loss dB Min	Power AVG Watts @ 95 °C	Operating Temp. °C
23	20	-55 to +150
23	20	-55 to +150

*Specification based on performance of unit properly installed on TTM Technologies Test Board with small signal applied. Specifications subject to change without notice. Refer to parameter definitions for details.

Mechanical Outline:

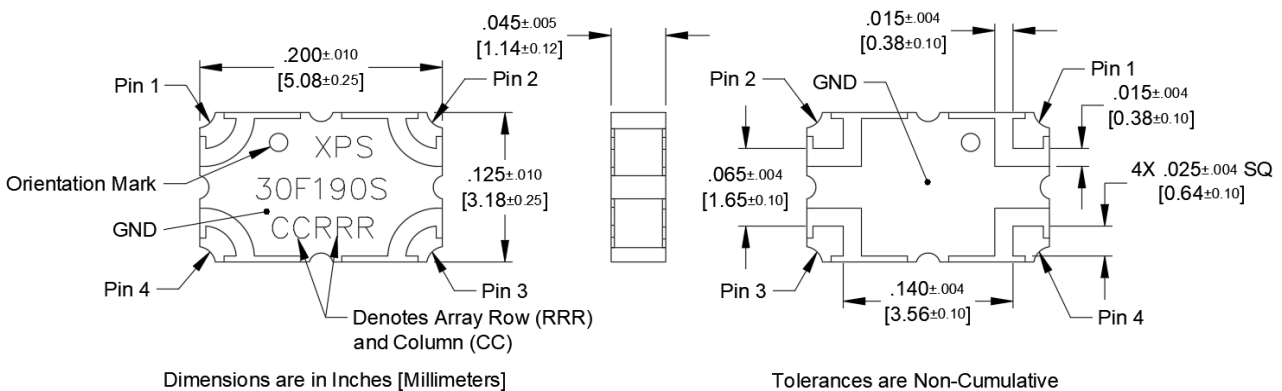

Phase Shifter Pin Configuration

The XPS30F190S has an orientation marker to denote Pin 1. Once port one has been identified the other ports are known automatically. Please see the chart below for clarification:

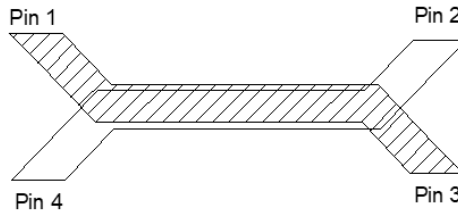

90 degree Phase Shifter Pin Configuration

Pin 1	Pin 2	Pin 3	Pin 4
Input 1	Input 2	90° delay from Input 1	90° delay from Input 2
90° delay from Input 1	90° delay from Input 2	Input 1	Input 2

Note: Pin 3 has a DC connection to the Pin 1, and the Pin 4 has a DC connection to Pin 2. Pin 4 to Pin 1 will provide 180 degree phase delay by connecting Pin 2 and Pin 3. Pin 2 and Pin 3 will provide 180 degree phase delay by connecting Pin 1 and Pin 4.

Peak Power Handling

High-Pot testing of these phase shifters during the qualification procedure resulted in a minimum breakdown voltage of 1.22Kv (minimum recorded value). This voltage level corresponds to a breakdown resistance capable of handling at least 12dB peak over average power levels, for very short durations. The breakdown location consistently occurred across the air interface at the phase shifter contact pads (see illustration below). The breakdown levels at these points will be affected by any contamination in the gap area around these pads. These areas must be kept clean for optimum performance. It is recommended that the user test for voltage breakdown under the maximum operating conditions and over worst case modulation induced power peaking. This evaluation should also include extreme environmental conditions (such as high humidity).

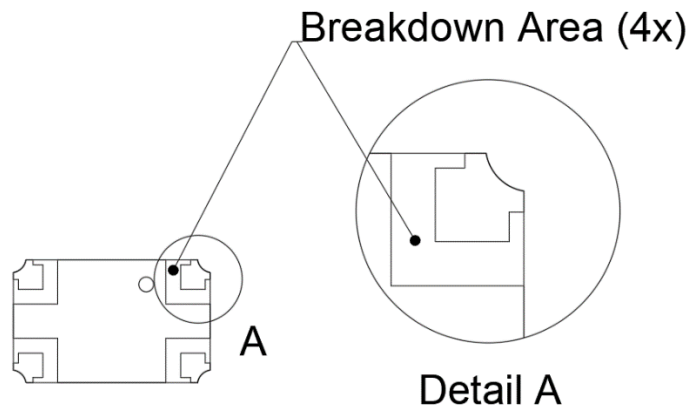

Insertion Loss and Power Derating Curves:

XPS30F190S Typical Insertion Loss Derating Curve

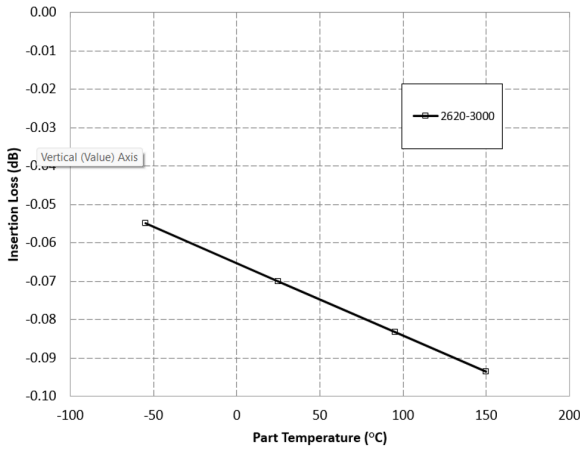

XPS30F190S Power Derating Curve

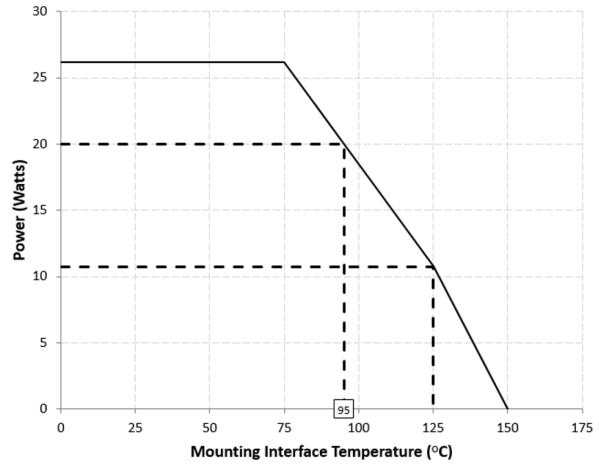

Insertion Loss Derating:

The insertion loss, at a given frequency, of the phase shifters is measured at 25°C and then averaged. The measurements are performed under small signal conditions (i.e. using a Vector Network Analyzer). The process is repeated at 95°C and 150°C. A best-fit line for the measured data is computed and then plotted from -55°C to 150°C.

Power Derating:

The power handling and corresponding power derating plots are a function of the thermal resistance, mounting surface temperature (base plate temperature), maximum continuous operating temperature of the phase shifter, and the thermal insertion loss. The thermal insertion loss is defined in the Power Handling section of the data sheet.

As the mounting interface temperature approaches the maximum continuous operating temperature, the power handling decreases to zero.

If mounting temperature is greater than 95°C, the Xinger® component will perform reliably as long as the input power is derated to the curve above.

Typical Performance at 2620-2690 MHz, 2900–3000 MHz:

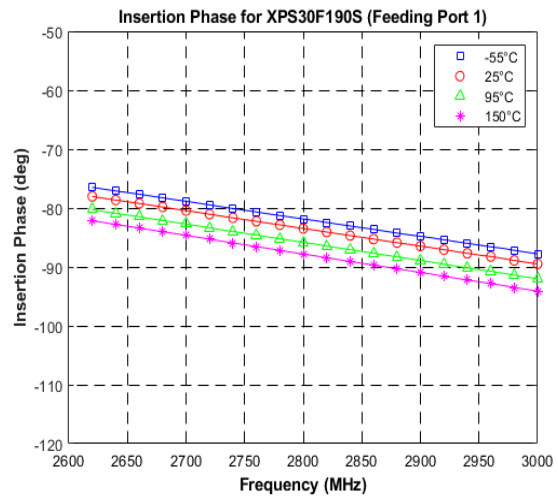
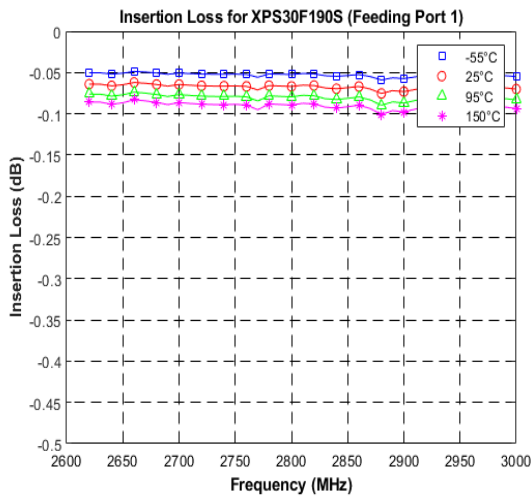
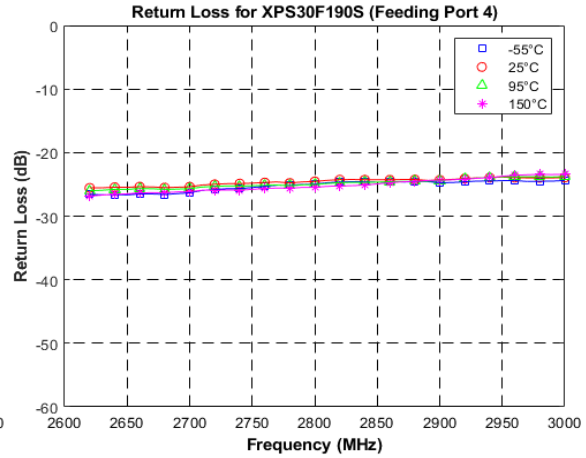
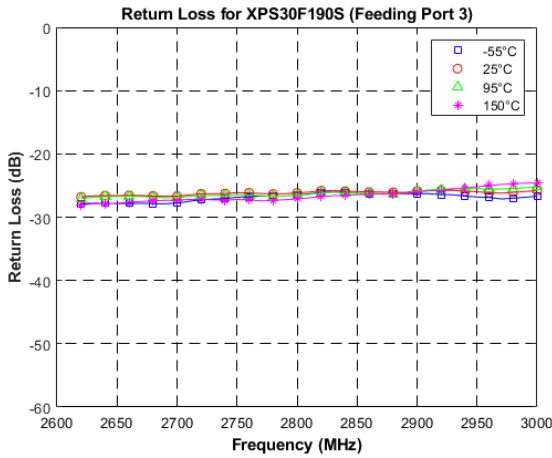
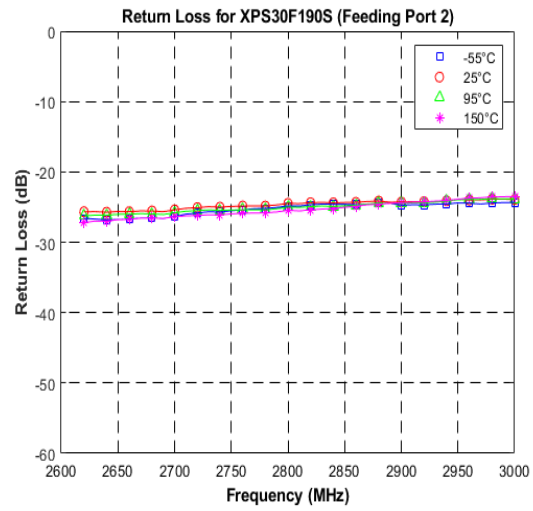
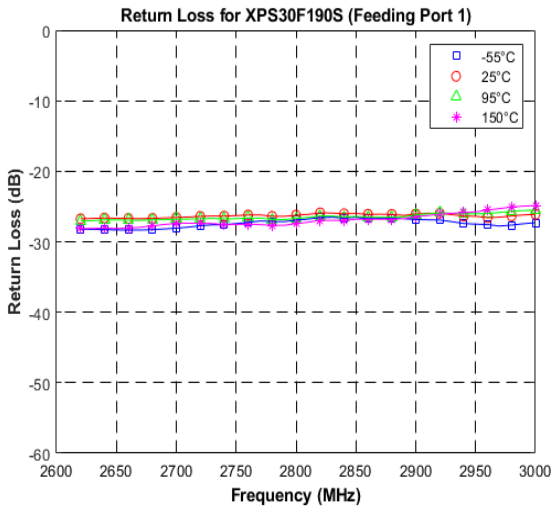

Definition of Measured Specifications

To guarantee the part performance, the part is measured with Pin n connected to Port n (where n=1, 2, 3, 4).

Parameter	Definition	Mathematical Representation
Return Loss	The impedance match of the phase shifter to a 50Ω system.	$Return\ Loss(dB) = 20\log S_{nn} $
Insertion Loss	The ratio of output power over input power.	$Insertion\ Loss(dB) = 10\log S_{13}^2 $ $Insertion\ Loss(dB) = 10\log S_{24}^2 $
Insertion Phase	The phase difference from Pin 1 to Pin 3 and from Pin 2 to Pin 4 at $W_c = 1000MHz$	$Insertion\ Phase(degree) = Phase(S_{13}(W_c))$ $Insertion\ Phase(degree) = Phase(S_{24}(W_c))$

Packaging and Ordering Information:

Parts are available in reels. Packaging follows EIA 481 for reels. Parts are oriented in tape and reel as shown below. Tape and reel is available in 4000 pcs per reel.

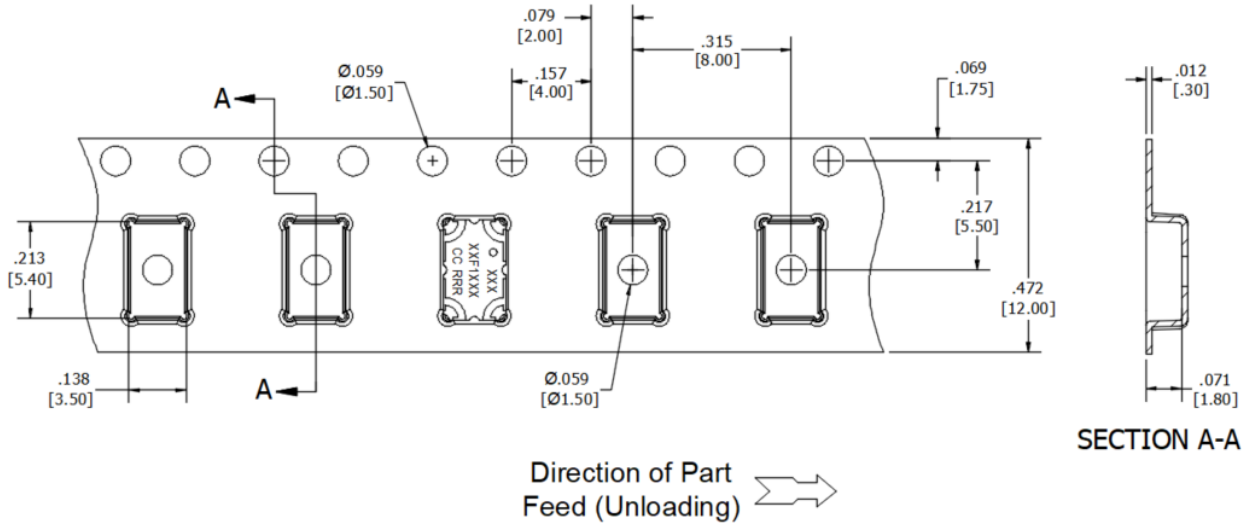

Dimensions are in Inches [Millimeters]

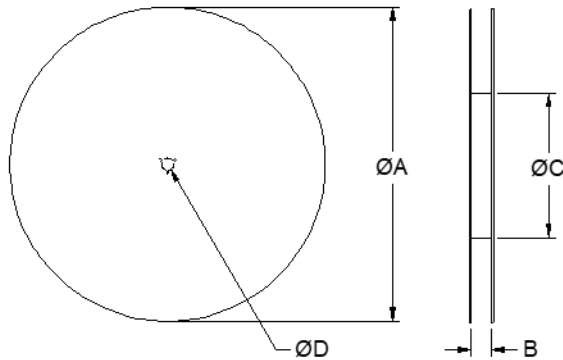

TABLE 1	
REEL DIMENSIONS (Inches[mm])	
ØA	13.0 [330.0]
B	.472 [12.0]
ØC	4.017 [102.03]
ØD	.512 [13.0]

Contact us:
rf&s_support@ttm.com