

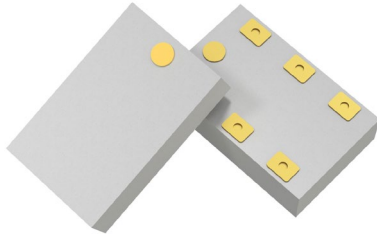

Power Divider
0805 50Ω

Description:

The PD1728J5050S2HF is a low profile, sub-miniature (0805) Wilkinson power divider in an easy to use Xinger style surface mount package. The PD1728J5050S2HF is ideal for high volume manufacturing and delivers higher performances than traditional printed and lumped element solutions. The PD1728J5050S2HF is matched to 50 Ω, which is ideal for high-level integrations in the following markets: 5G & L&S-Band COTS Mil-Aero. The PD1728J5050S2HF does not include the resistive element and therefore, requires an external resistor for operation. The PD1728J5050S2HF is available on tape and reel for high volume manufacturing pick and place.



All of the Xinger components are constructed from ceramic filled PTFE composites which possess excellent electrical and mechanical stability. All parts have been subjected to rigorous Xinger qualification testing and units are 100% RF tested.

Features:

- 1700-2850 MHz
- 0.53mm Height
- 5G, L&S-Band COTS Mil-Aero
- 50Ω Input
- 50Ω Output
- Low Insertion Loss
- Surface Mountable
- Tape & Reel
- Isolated Surface
- RoHS Compliant
- Halogen Free

Electrical Specifications*:

Parameter (@25°C)	Min	Typ	Max	Unit
Frequency	1700		2850	MHz
Input Port Impedance		50		Ω
Output Port Impedance		50		Ω
Return Loss	12	13		dB
Insertion Loss		0.4	0.6	dB
Amplitude Balance		0.05	0.1	dB
Phase Balance		1	2	Degrees
Isolation (Output Ports)	13	14		dB
Power Handling @ 105°C			2	Watts
Operating Temperature	-55		+140	°C

*Specifications subject to change without notice.

Outline Drawing:

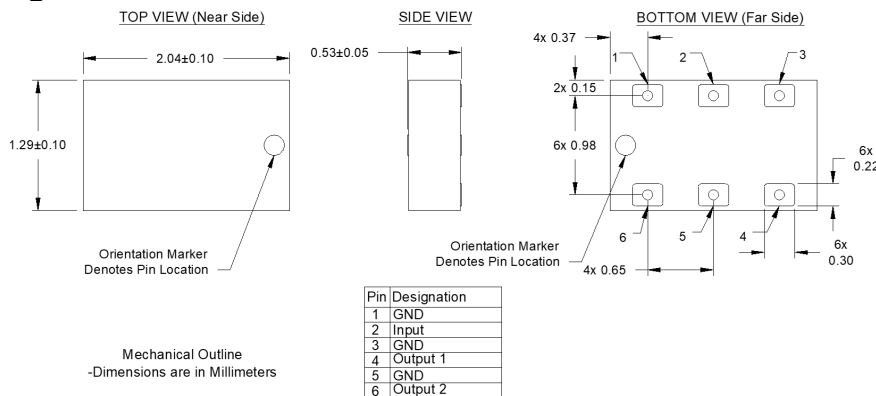

Insertion Loss and Power Derating Curves:

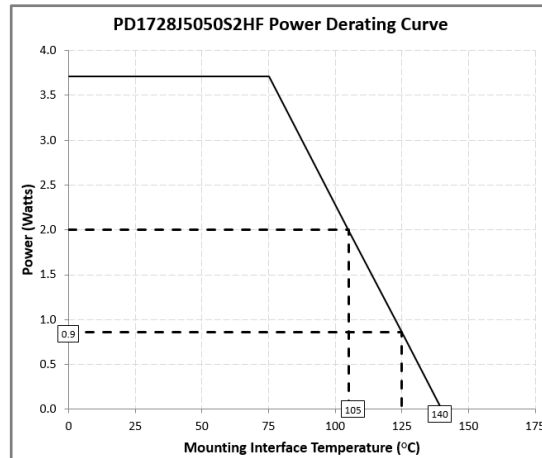
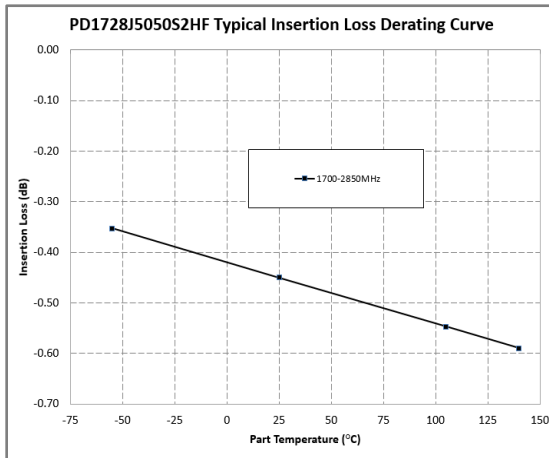

Insertion Loss Derating:

The insertion loss, at a given frequency, of the power divider is measured at 25°C and then averaged. The measurements are performed under small signal conditions (i.e. using a Vector Network Analyzer). The process is repeated at -55°C, 105°C, and 140°C. A best-fit line for the measured data is computed and then plotted from -55°C to 140°C.

Power Derating:

The power handling and corresponding power derating plots are a function of the thermal resistance, mounting surface temperature (base plate temperature), maximum continuous operating temperature of the power divider, and the thermal insertion loss. The thermal insertion loss is defined in the Power Handling section of the data sheet.

As the mounting interface temperature approaches the maximum continuous operating temperature, the power handling decreases to zero.

If mounting temperature is greater than 105°C, the Xinger power divider will perform reliably as long as the input power is derated to the curve above.

Broadband Performance: 10 MHz to 8010 MHz

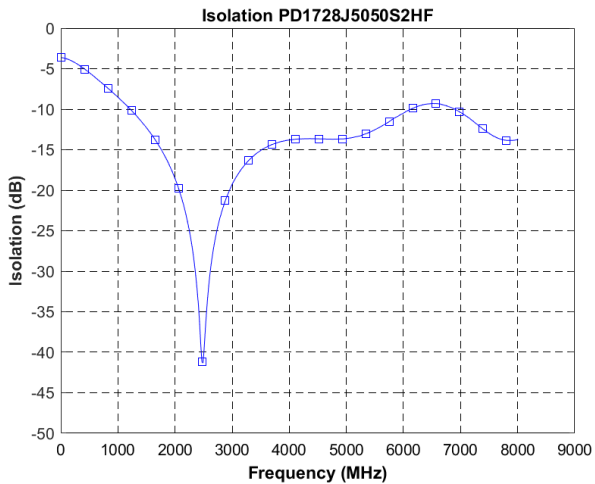
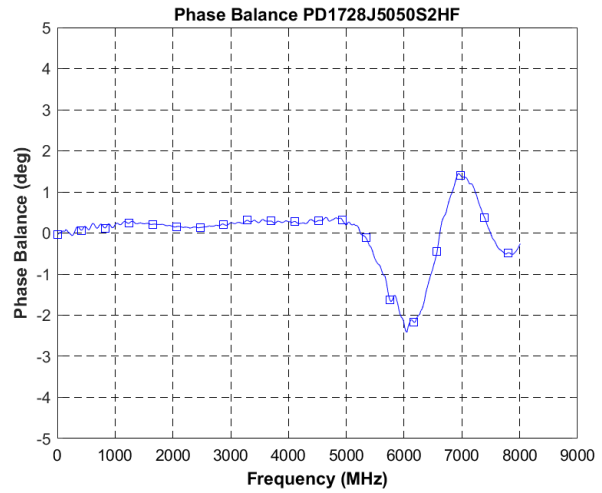
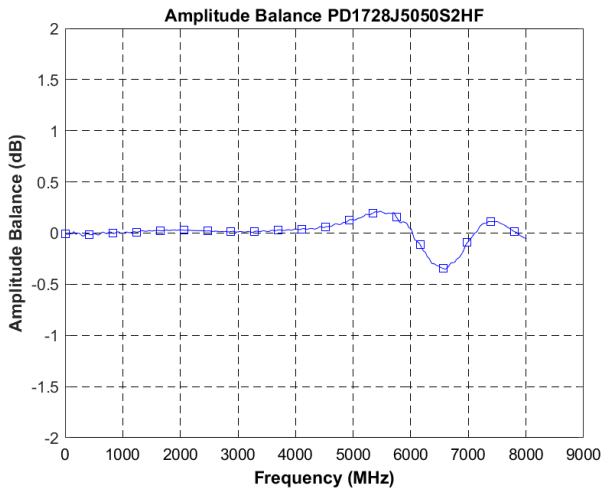
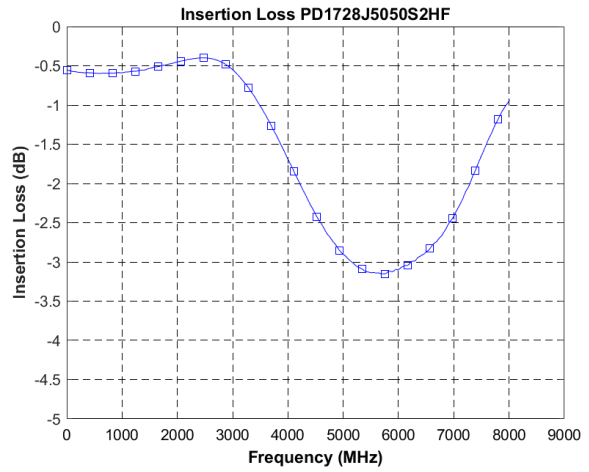
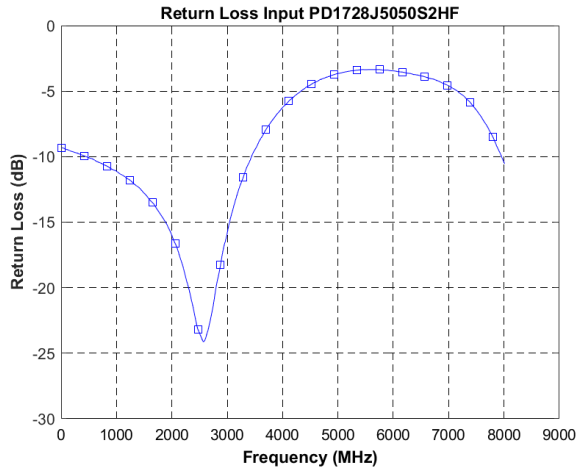

Typical Performance: 1700 MHz to 2850MHz

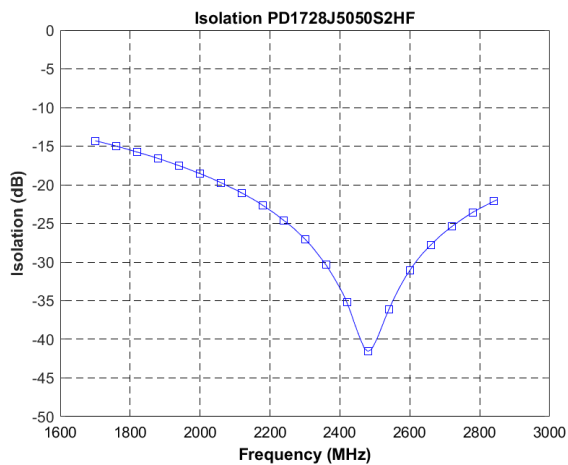
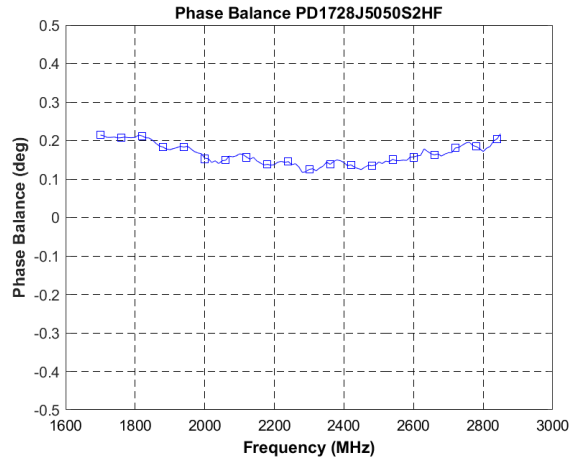
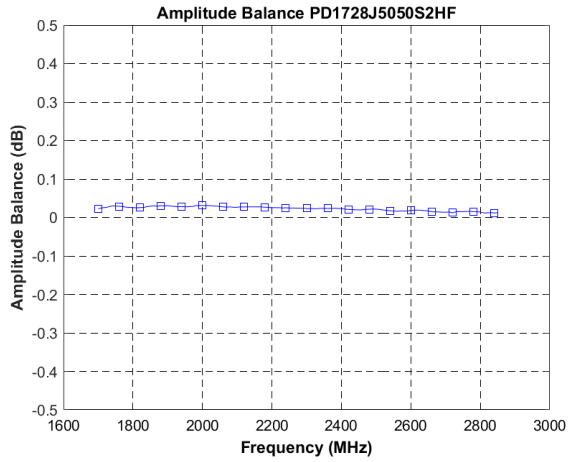
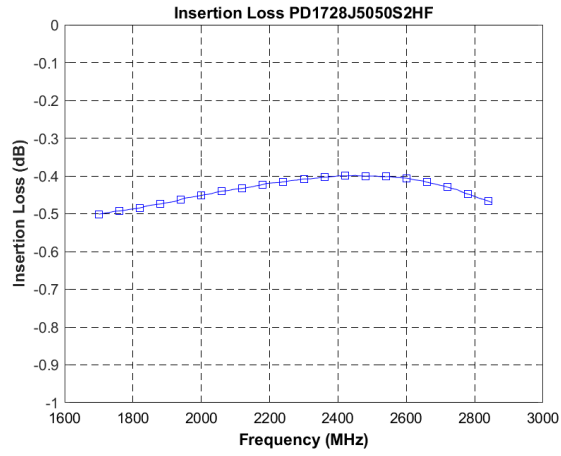
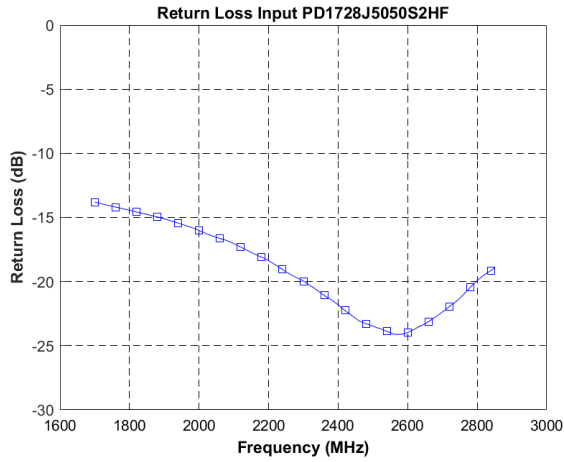

Definition of Measured Specifications:

Parameter	Definition	Mathematical Representation
Insertion Loss	The measure of the sum of the power at outputs reference to the input power	$IL(dB) = 10Log_{10}(S_{21} ^2 + S_{31} ^2)$
Return Loss	The measure of the power of the signal reflected by discontinuity in a transmission line relative to incident power	$RL_{IN}(dB) = 20Log_{10}(S_{11})$ $RL_{out1}(dB) = 20Log_{10}(S_{22})$ $RL_{out2}(dB) = 20Log_{10}(S_{33})$
Isolation	The measure of the power of the signal reflected by discontinuity in a transmission line relative to incident power	$ISO_{23}(dB) = 20Log_{10}(S_{23})$
Amplitude Balance	The measure of the difference in power levels between each of the two outputs	$ABal_{23}(dB) = 20Log_{10} S_{21}/S_{31} $
Phase Balance	The measure of the difference in phase between each of the two outputs.	$PBal_{23}(degree) = ang(S_{21}/S_{31})$

*Parts are 100% RF tested as per spec definition.

** Refer to page 1 for port assignment

Peak Power Handling:

High-Pot testing of these components during the qualification procedure resulted in a minimum breakdown voltage of 1Kv (minimum recorded value). This voltage level corresponds to a breakdown resistance capable of handling at least 12dB peak over average power levels, for very short durations. The breakdown location consistently occurred across the pads and the ground pads. The breakdown levels at these points will be affected by any contamination in the gap area around these pads. These areas must be kept clean for optimum performance. It is recommended that the user test for voltage breakdown under the maximum operating conditions and over worst case modulation induced power peaking. This evaluation should also include extreme environmental conditions (such as high humidity).

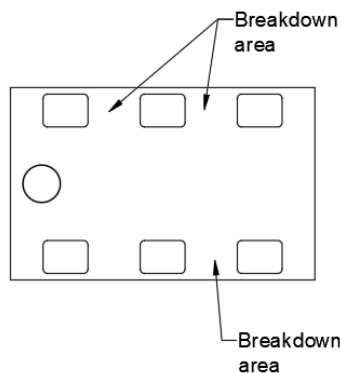

Packaging and Ordering Information:

Parts are available in reel and are packaged per EIA 481. Parts are oriented in tape and reel as shown below. Minimum order quantities are 4000 per reel.

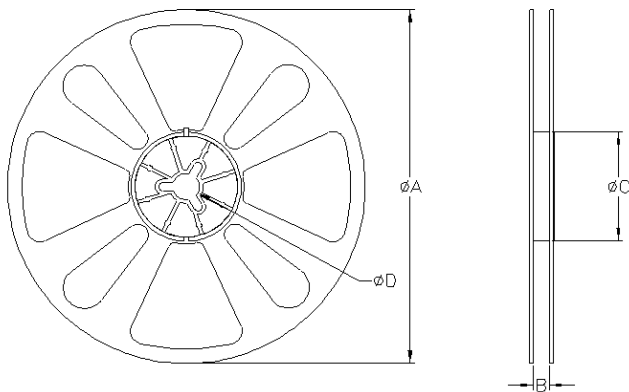
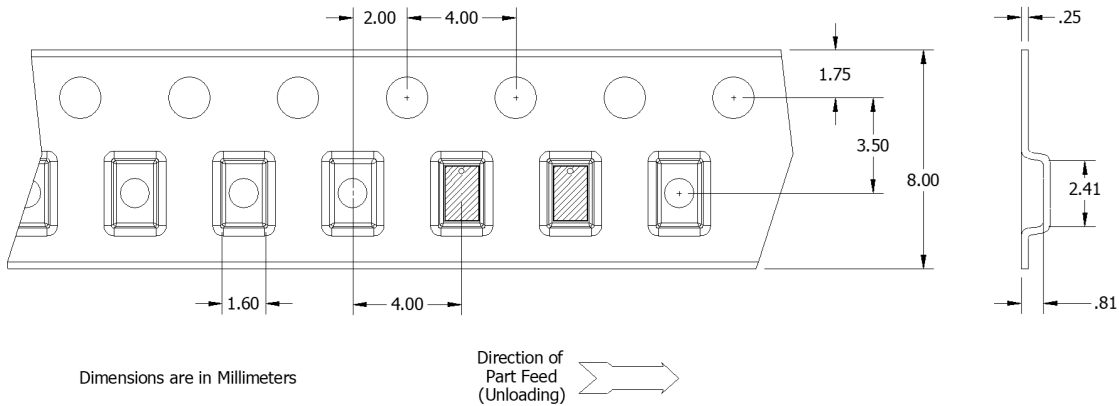

TABLE 1		
QUANTITY/REEL	REEL DIMENSIONS mm	
4000	ØA	177.80
	B	8.00
	ØC	50.80
	ØD	13.00

Contact us:
rf&s_support@ttm.com