

Xinger III

Uneven Split Quadrature Coupler 4 dB, 90°

Description:



The X3C07F1-04S is a low profile, high performance uneven split quadrature dB coupler, with a power rating of 25 watts (AVG) and a peak to average ratio of 12dB, in a new easy to use, Xinger style manufacturing friendly surface mount package. It is designed particularly for 5G, LTE and Sub-1GHz applications in all end markets. The X3C07F1-04S can be used as power splitters in power splitting and combining, where tightly controlled coupling and low insertion loss is required.

Parts have been subjected to rigorous Xinger qualification testing, and they are manufactured using materials with coefficients of thermal expansion (CTE) compatible with common substrates such as FR4, RF-35, RO4350 and polyimide. Produced with 6 of 6 RoHS compliant tin immersion finish.

Features:

- 600-1000 MHz
- 5G, LTE, Sub-1GHz Applications
- Power 25W (AVG)
- Peak to Average Ratio 12dB
- Very Low Los (<0.23dB)
- Tight Coupling (± 0.30 dB)
- High Directivity (>18dB)
- Tape and Reel
- Lead Free

Electrical Specifications*:

Frequency <i>MHz</i>	Mean Coupling <i>dB</i>	Insertion Loss <i>dB Max</i>	VSWR <i>Max:1</i>
600-1000	4.20 \pm 0.30	0.23	1.22
695-805	4.00 \pm 0.30	0.15	1.15
869-894	4.10 \pm 0.30	0.18	1.15
925-960	4.35 \pm 0.30	0.20	1.22
Directivity <i>dB min</i>	Phase Balance <i>Degrees</i>	Power <i>Avg. Watts@105° C</i>	Operating Temp. <i>°C</i>
18	90 \pm 4.0	25	-55 to +150
21	90 \pm 4.0	25	-55 to +150
21	90 \pm 4.0	25	-55 to +150
18	90 \pm 4.0	25	-55 to +150

*Specification based on performance of unit properly installed on TTM Technologies Test Board with small signal applied. *Specifications subject to change without notice. Refer to parameter definitions for details.

Outline Drawing:

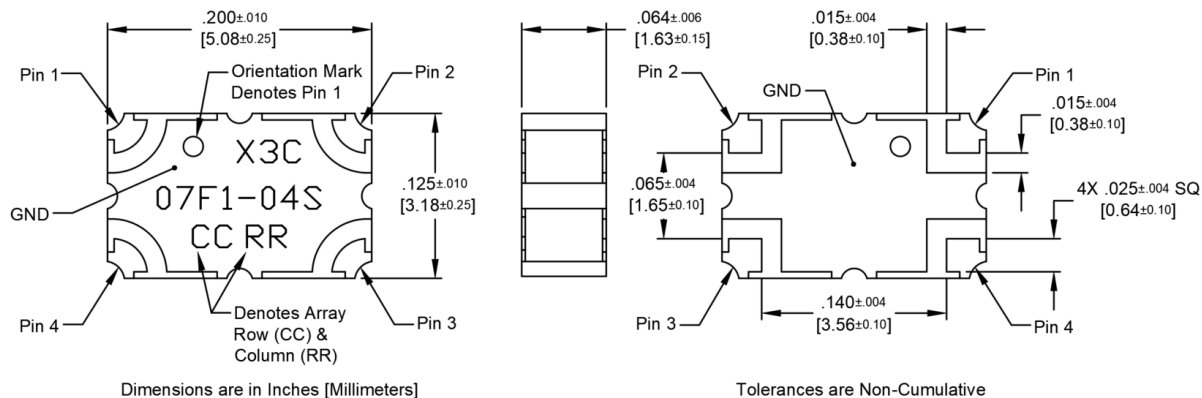

Pin Configuration:

The X3C07F1-04S has an orientation marker to denote Pin 1. Once port one has been identified the other ports are known automatically. Please see the chart below for clarification:

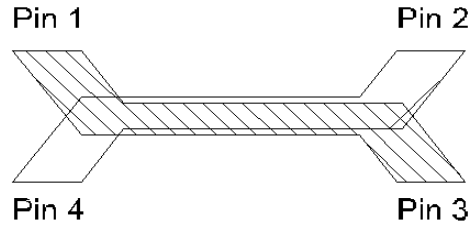

Configuration	Pin 1	Pin 2	Pin 3	Pin 4
Splitter	Input	Isolated	-2.2dB $\angle \Theta -90$	-4dB $\angle \Theta$
Splitter	Isolated	Input	-4dB $\angle \Theta$	-2.2dB $\angle \Theta -90$
Splitter	-2.2dB $\angle \Theta -90$	-4dB $\angle \Theta$	Input	Isolated
Splitter	-4dB $\angle \Theta$	-2.2dB $\angle \Theta -90$	Isolated	Input

Note: The direct port has a DC connection to the input port and the coupled port has a DC connection to the isolated port.

Peak Power Handling:

High-Pot testing of these couplers during the qualification procedure resulted in a minimum breakdown voltage of 1.49 KV (minimum recorded value). This voltage level corresponds to a breakdown resistance capable of handling at least 12dB peaks over average power levels, for very short durations. The breakdown location consistently occurred across the air interface at the coupler contact pads (see illustration below). The breakdown levels at these points will be affected by any contamination in the gap area around these pads. These areas must be kept clean for optimum performance. It is recommended that the user test for voltage breakdown under the maximum operating conditions and over worst-case modulation induced power peaking. This evaluation should also include extreme environmental conditions (such as high humidity).

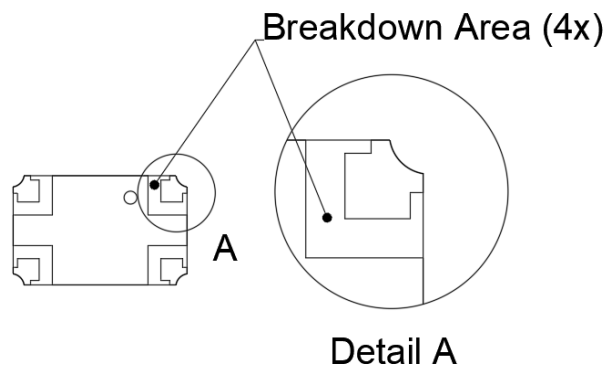

Insertion Loss and Power Derating Curves:

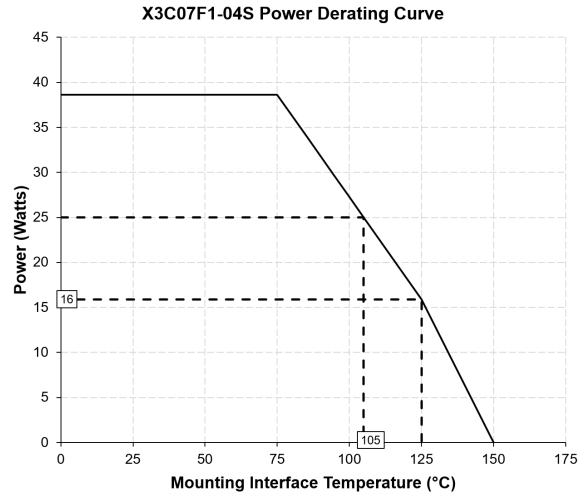
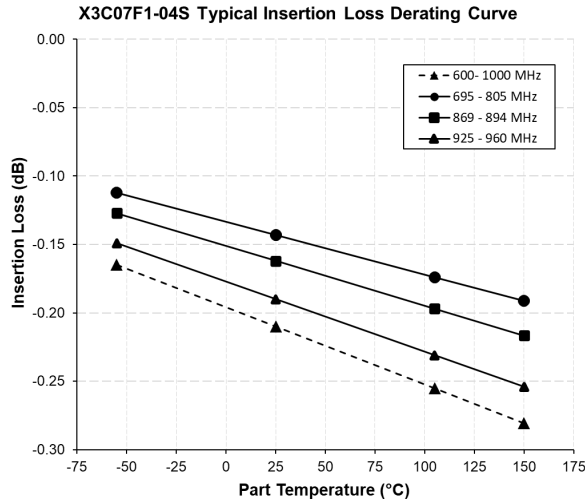

Insertion Loss Derating:

The insertion loss, at a given frequency, of the coupler is measured at 25°C and then averaged. The measurements are performed under small signal conditions (i.e. using a Vector Network Analyzer). The process is repeated at -55°C, 105°C and 150°C. A best-fit line for the measured data is computed and then plotted from -55°C to 150°C.

Power Derating:

The power handling and corresponding power derating plots are a function of thermal resistance, mounting surface temperature (base plate temperature), maximum continuous operating temperature of the coupler, and the thermal insertion loss. The thermal insertion loss is defined in the Power Handling section of the data sheet.

As the mounting interface temperature approaches the maximum continuous operating temperature, the power handling decreases to zero.

If mounting temperature is greater than 105°C, the Xinger coupler will perform reliably if the input power is derated to the curve above.

Typical Performance:

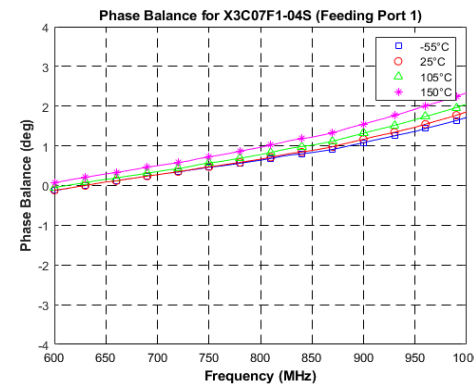
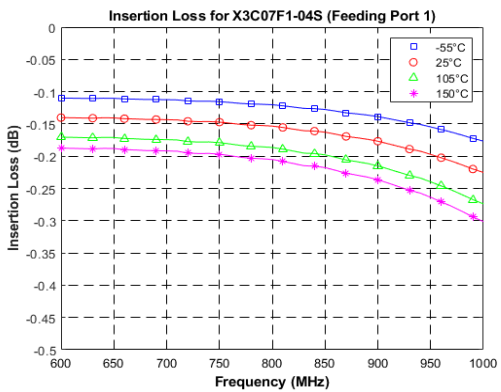
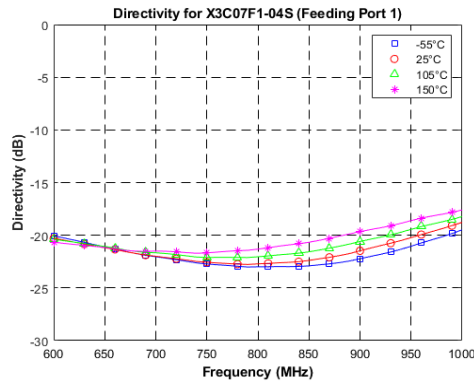
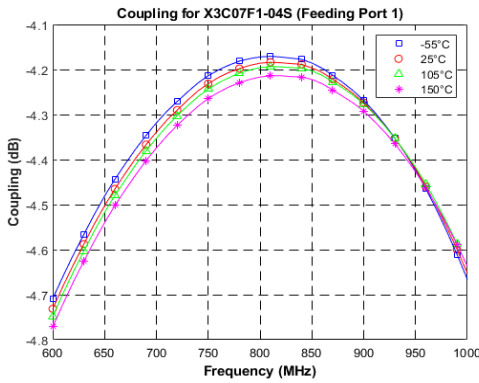
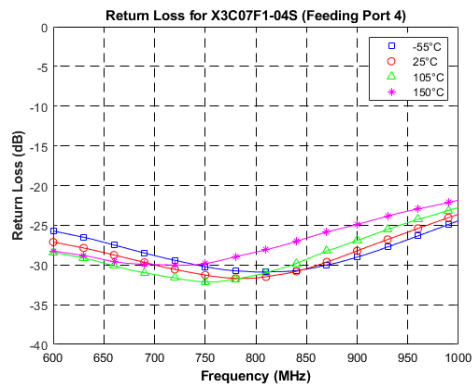
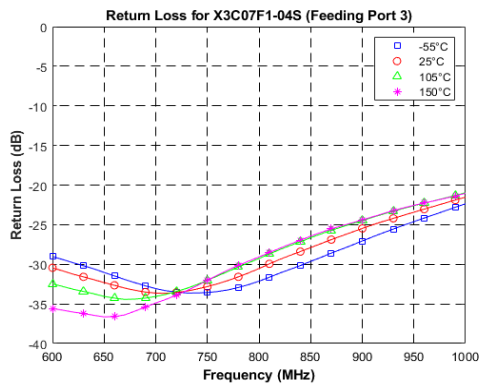
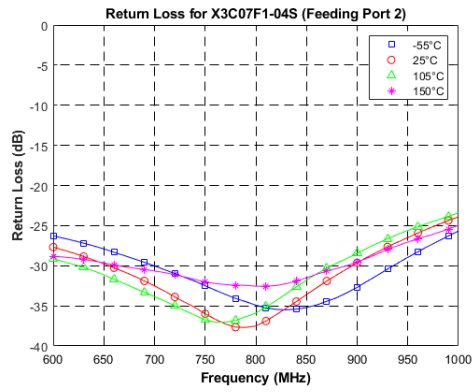
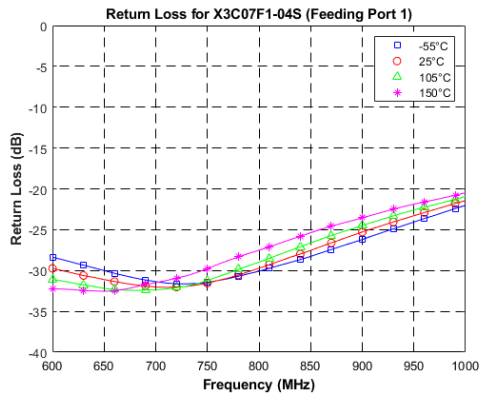

Definition of Measured Specifications:

Parameter	Definition	Mathematical Representation
VSWR (Voltage Standing Wave Ratio)	The impedance match of the coupler to a 50Ω system. A VSWR of 1:1 is optimal.	$VSWR = \frac{V_{max}}{V_{min}}$ Vmax = voltage maxima of a standing wave Vmin = voltage minima of a standing wave
Return Loss	The impedance match of the coupler to a 50Ω system. Return Loss is an alternate means to express VSWR.	$Return\ Loss(dB) = 20\log \frac{VSWR+1}{VSWR-1}$
Mean Coupling	At a given frequency (ω_n), coupling is the input power divided by the power at the coupled port. Mean coupling is the average value of the coupling values in the band. N is the number of frequencies in the band.	$Coupling(dB) = C(\omega_n) = 10\log \frac{P_{in}(\omega_n)}{P_{cpl}(\omega_n)}$ $Mean\ Coupling(dB) = \frac{\sum_{n=1}^N C(\omega_n)}{N}$
Insertion Loss	The input power divided by the sum of the power at the two output ports.	$Insertion\ Loss(dB) = 10\log \frac{P_{in}}{P_{cpl} + P_{direct}}$
Directivity	The power at the coupled port divided by the power at the isolated port.	$10\log \frac{P_{cpl}}{P_{iso}}$
Phase Balance	The difference in phase angle between the two output ports.	Phase at coupled port – Phase at direct port

Packaging and Ordering Information:

Parts are available in reels. Packaging follows EIA 481 for reels. Parts are oriented in tape and reel as shown below. Tape and reel is available in 4000 pcs per reel.

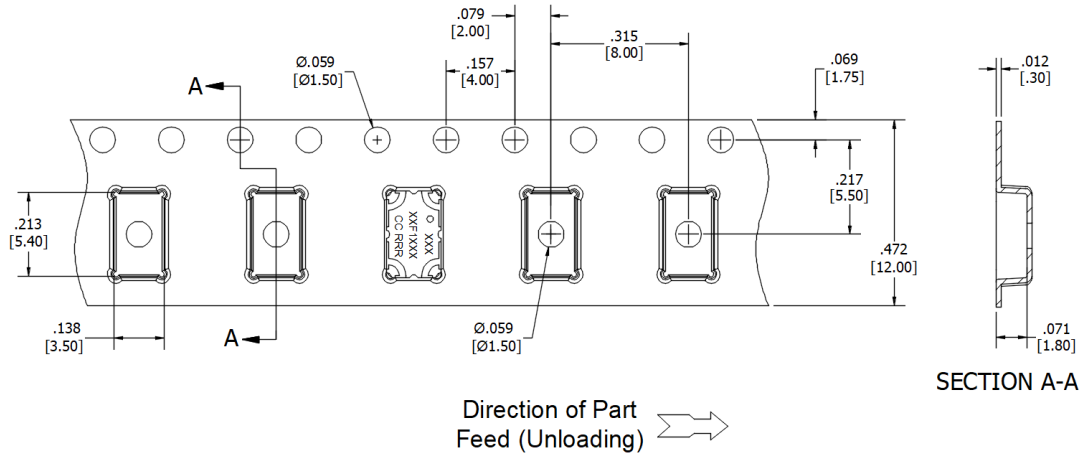

Dimensions are in Inches [Millimeters]

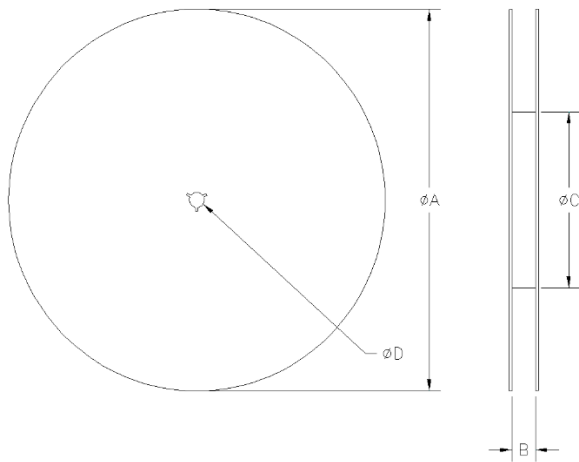

**TABLE 1 (for 4000 pcs)
REEL DIMENSIONS: inches [mm]**

ØA	13.0 [330.00]
B	0.472 [12.0]
ØC	4.017 [102.03]
ØD	0.512 [13.0]

X3C 07 F 1 - 04 S

Function & Family	Frequency	Package Size	Power Handling	Coupling	Finish
X3C = Xinger 3 Coupler	07 = typ freq 0.7 GHz	F = 0.200" x 0.125"	1 = 1-100W	04 = 4dB	S = Immersion Tin

Contact us:
rf&s_support@ttm.com