



**Uneven Split Quadrature Coupler  
5dB, 90°**



**Description:**

The X4C20K1-05S is a low profile, high performance uneven split quadrature 5dB coupler, with a power rating of 10 watts (AVG) and a peak to average ratio of 12dB, in a new easy to use, Xinger style manufacturing friendly surface mount package. It is designed particularly for 5G, LTE and S-Band applications in all end markets including telecom and COTS Mil-Aero. The X4C20K1-05S can be used as power splitters in power splitting and combining, where tightly controlled coupling and low insertion loss is required.

Parts have been subjected to rigorous Xinger qualification testing and they are manufactured using materials with coefficients of thermal expansion (CTE) compatible with common substrates such as FR4, RF-35, RO4350 and polyimide. Produced with 6 of 6 RoHS compliant tin immersion finish.

**Features:**

- 1700-2300 MHz
- Doherty Amplifier Splitter
- Power 10W (AVG)
- Peak to Average Ratio 12dB
- 5G, LTE, S-Band COTS Mil-Aero
- Very Low Loss (<0.3dB)
- Tight Coupling ( $\pm 0.35$ dB)
- High Isolation (>20dB)
- Production Friendly
- Tape and Reel
- Lead Free

**Electrical Specifications\***

Frequency	Isolation	Insertion Loss	Return Loss
MHz	dB Min	dB Max	dB Min
1700-2300	20	0.30	20
Coupling	Phase Balance	Power	Operating Temp.
dB	Degrees	Avg. Watts @105°C	°C
5 $\pm$ 0.35	90 $\pm$ 4.0	10	-55 to +150

\*Specification based on performance of unit properly installed on TTM Test Board with small signal applied. Specifications subject to change without notice. Refer to parameter definitions for details.

**Outline Drawing:**

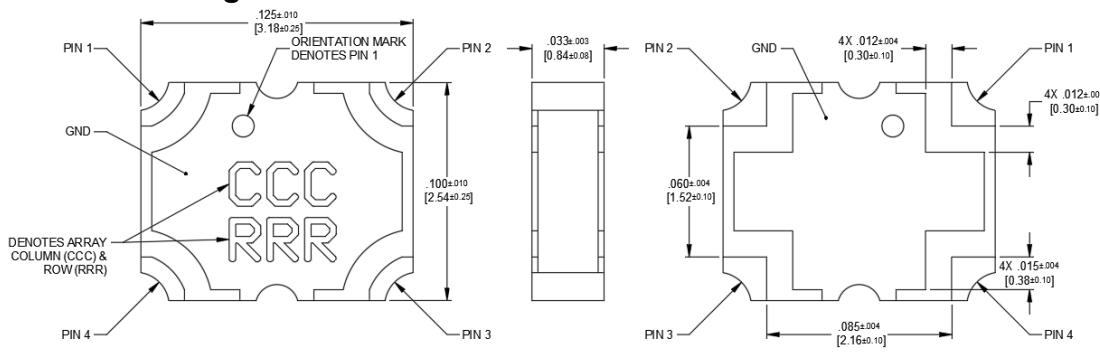

Dimensions are in Inches [Millimeters]  
X4C20K1-05S Mechanical Outline

### Coupler Pin Configuration:

The X4C20K1-05S has an orientation marker to denote Pin 1. Once port one has been identified the other ports are known automatically. Please see the chart below for clarification:

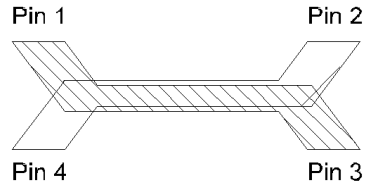

Configuration	Pin 1	Pin 2	Pin 3	Pin 4
<b>Splitter</b>	Input	Isolated	-2dB < $\Theta$ -90	-5dB < $\Theta$
<b>Splitter</b>	Isolated	Input	-5dB < $\Theta$	-2dB < $\Theta$ -90
<b>Splitter</b>	-2dB < $\Theta$ -90	-5dB < $\Theta$	Input	Isolated
<b>Splitter</b>	-5dB < $\Theta$	-2dB < $\Theta$ -90	Isolated	Input

### Peak Power Handling:

High-Pot testing of these couplers during the qualification procedure resulted in a minimum breakdown voltage of 1.16 Kv (minimum recorded value). This voltage level corresponds to a breakdown resistance capable of handling at least 12dB peak over average power levels, for very short durations. The breakdown location consistently occurred across the air interface at the coupler contact pads (see illustration below). The breakdown levels at these points will be affected by any contamination in the gap area around these pads. These areas must be kept clean for optimum performance. It is recommended that the user test for voltage breakdown under the maximum operating conditions and over worst case modulation induced power peaking. This evaluation should also include extreme environmental conditions (such as high humidity).

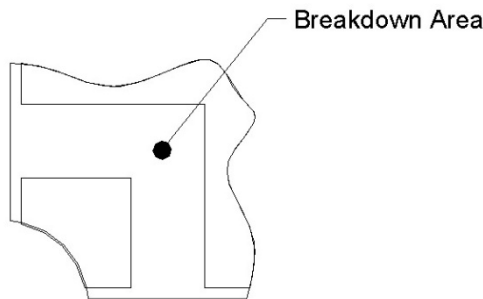

### Insertion Loss and Power Derating Curves:

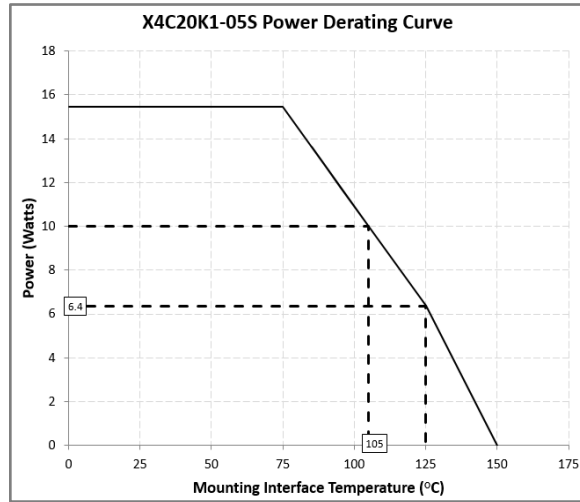
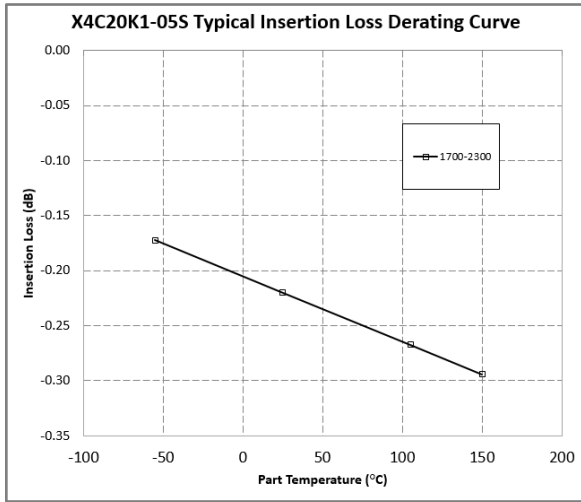

#### Insertion Loss Derating:

The insertion loss, at a given frequency, of the coupler is measured at 25°C and then averaged. The measurements are performed under small signal conditions (i.e. using a Vector Network Analyzer). The process is repeated at -55°C, 105°C and 150°C. A best-fit line for the measured data is computed and then plotted from -55°C to 150°C.

#### Power Derating:

The power handling and corresponding power derating plots are a function of the thermal resistance, mounting surface temperature (base plate temperature), maximum continuous operating temperature of the coupler, and the thermal insertion loss. The thermal insertion loss is defined in the Power Handling section of the data sheet.

As the mounting interface temperature approaches the maximum continuous operating temperature, the power handling decreases to zero.

If mounting temperature is greater than 105°C, the Xinger coupler will perform reliably as long as the input power is derated to the curve above.

**Typical Performance: 1500 – 2400 MHz**

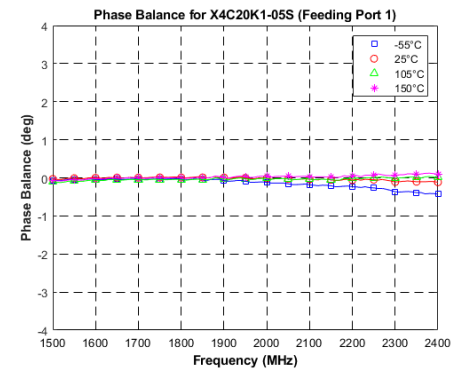
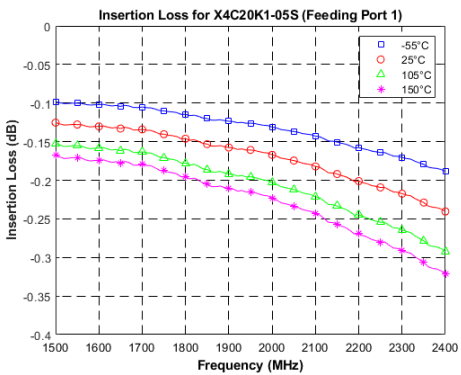
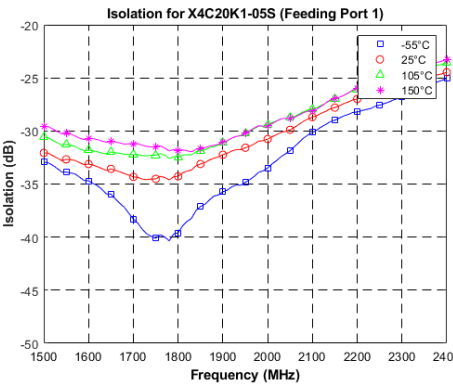
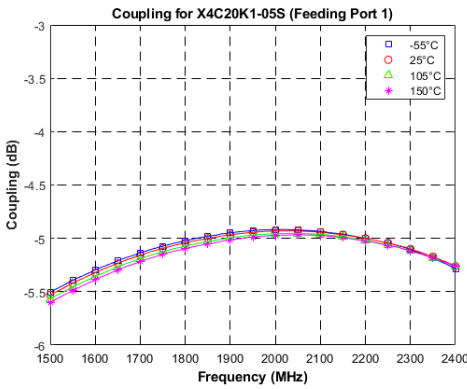
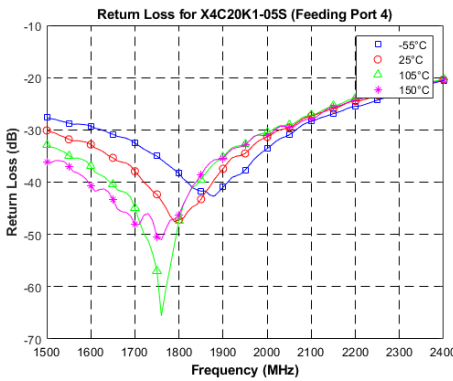
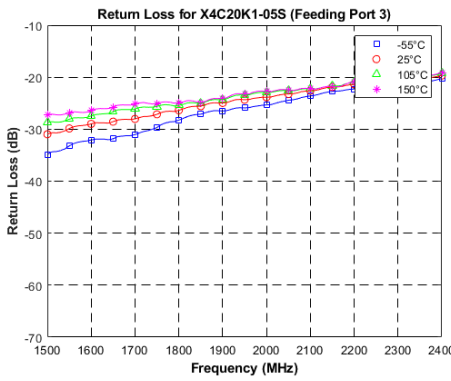
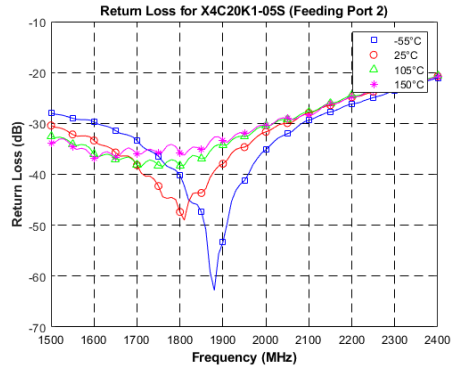
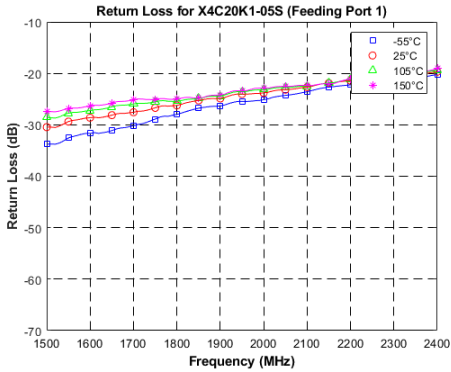

**Definition of Measured Specifications:**

Parameter	Definition	Mathematical Representation
<b>VSWR</b> (Voltage Standing Wave Ratio)	The impedance match of the coupler to a 50Ω system. A VSWR of 1:1 is optimal.	$VSWR = \frac{V_{max}}{V_{min}}$ Vmax = voltage maxima of a standing wave Vmin = voltage minima of a standing wave
<b>Return Loss</b>	The impedance match of the coupler to a 50Ω system. Return Loss is an alternate means to express VSWR.	$Return\ Loss(dB) = 20\log \frac{VSWR + 1}{VSWR - 1}$
<b>Insertion Loss</b>	The input power divided by the sum of the power at the two output ports.	$Insertion\ Loss(dB) = 10\log \frac{P_{in}}{P_{cpl} + P_{direct}}$
<b>Isolation</b>	The input power divided by the power at the isolated port.	$10\log \frac{P_{cpl}}{P_{iso}}$
<b>Phase Balance</b>	The difference in phase angle between the two output ports.	Phase at coupled port – Phase at direct port
<b>Coupling</b>	At a given frequency ( $\omega_n$ ), coupling is the input power divided by the power at the coupled port.	$Coupling(dB) = C(\omega_n) = 10\log \frac{P_{in}(\omega_n)}{P_{cpl}(\omega_n)}$
<b>Group Delay</b>	Group delay is average of group delay's from input port to the coupled port	Average ( GD-C)

**Packaging and Ordering Information:**

Parts are available in reels. Packaging follows EIA 481 for reels. Parts are oriented in tape and reel as shown below. Tape and reel is available in 500 and 8000 pcs per reel.

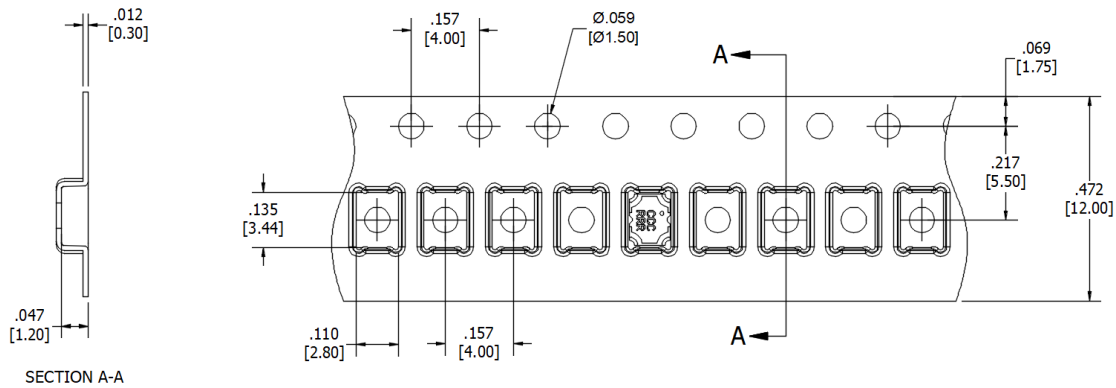

Dimensions are in Inches [Millimeters]

Direction of Part Feed (Unloading)

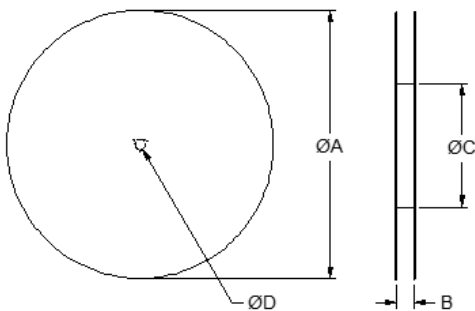

TABLE 1 (for 500 pcs)	
REEL DIMENSIONS (Inches [mm])	
ØA	7.0 [177.8]
B	.472 [12.0]
ØC	2.0 [50.8]
ØD	.512 [13.0]

TABLE 2 (for 8000 pcs)	
REEL DIMENSIONS (Inches [mm])	
ØA	13.0 [330.0]
B	.472 [12.0]
ØC	4.017 [102.03]
ØD	.512 [13.0]

Contact us:  
[rf&s\\_support@ttm.com](mailto:rf&s_support@ttm.com)